



**FAQS on Instrumentation for Permanent
Measurement and Verification (M&V)
for Chilled Water Plant System**

[Updated Jun 2018]

TEMPERATURE

Q1. Why is it important to measure accurately the temperature difference between the supply and return of the chilled or condenser water?

The temperature difference between the chilled/condenser water supply and return temperature ($^{\circ}\text{C}$) is used to compute the net cooling load delivered to the building, or amount of energy consumed by AHUs/FCUs (air handling units/ fan coil units). As an illustration, for a chilled water plant operating with a chilled water supply and return temperature difference of 5°C , a seemingly acceptable error of $\pm 0.5^{\circ}\text{C}$ can in fact lead to a 20% error in the final computation of the system cooling load.

In addition, many energy audits conducted on existing buildings have shown that a large number of existing chiller plants experience a low delta T syndrome (i.e. temperature difference of about 2°C to 3°C), especially when they operate at part load conditions. In such circumstances, the error in the cooling load computation is even greater.

A maximum uncertainty of $\pm 0.05^{\circ}\text{C}$ end-to-end for each temperature measurement is thus required, to allow for optimisation of the plant operation. Since the lifetime of a typical chiller plant is 15 to 20 years, it is important to install highly accurate temperature sensors for long-term accurate trending of the operational efficiency of the plant.

Q2. What are the possible sources of error that may affect the end-to-end temperature uncertainty of $\pm 0.05^{\circ}\text{C}$?

The end-to-end uncertainty encompasses the entire chain of the temperature measurement process, i.e. the temperature sensor, transmitter, wiring, data acquisition system, etc. Typical sources that introduce errors in the measurement chain include:

i. Thermowell type

Temperature sensors installed in thermowells are not in direct contact with the water (ie Closed-end thermowell) and this might have an impact on the accuracy. In addition, the conductive thermal compound within the thermowells tends to dry out over time, which will affect thermal conductivity.

ii. Location of temperature sensors

Care should be taken if sensors for the chilled water supply are installed in locations exposed to direct sunlight. The metal parts of the sensor could easily reach 50°C due to direct solar radiation and this gives rise to inaccurate readings.

Installation of temperature sensors near pipe joints from 2 different sources might cause unstable measurements due to mixing of water temperatures.

iii. Use of transmitters

Some systems use transmitters to convert the sensor resistance from ohms to 4~20 milliamps (mA) DC signal to allow for transmission over a long distance. There is a tendency for the transmitters to drift over time, and be affected by ambient temperature fluctuations.

iv. A/D conversion in Data Logger

An additional source of error is introduced when an A/D convertor is used to convert the analogue signal of ohms or mA from the sensor or transmitter into digital signals for processing by a computer.

v. Affected by electromagnetic field

Most of the sensors are installed in environments with high Electromagnetic field, where a typical chiller plant room houses the chillers, pumps, fans, inverters, and

TEMPERATURE

sometimes, even high voltage transformers. The interference from the electromagnetic field due to these equipment may affect wireless or even improperly-shielded wired communication.

Q3. Why do we need a separate set of temperature sensors for measurement when there are sensors built within the chillers?

Most chillers in the market are factory-tested to rigorous standards in accordance to ANSI/AHRI Standard 550/590 which specifies an allowable tolerance of 5% for capacity, efficiency and heat balance. Separate meters are used during the factory test rather than the built-in sensors in order to achieve the required uncertainty level. Other measurement standards such as ASHRAE guideline 14 and ASHRAE Guideline 22 have also stated the use of independent sensors rather than the chiller's built-in sensors.

Q4. Does BCA Green Mark require temperature sensor for each chiller? Is it costly to install accurate temperature sensors to comply with GM NRB: 2015 or ENRB: 2017?

Temperature sensors are not required for individual chillers. For GM NRB: 2015 and ENRB: 2017 and V3.0, temperature sensors are to be provided for chilled water and condenser water loop at the main headers, i.e. two (2) for measuring the supply and return temperature at the chilled water header and two (2) at condenser water header, a total of four (4) temperature sensors.

Although these temperature sensors are more expensive than standard BAS sensors, each calibrated sensor can be procured at about S\$500.

Q5. Is there a list of suppliers/vendors who can offer market solution to meet accurate M&V requirement?

Highly accurate M&V instrumentation was introduced in public sector retrofit projects through the Guaranteed Energy Savings Performance (GESp) programme about 9 years ago. To date, the public sector has awarded more than 20 contracts with stringent M&V requirements. Many vendors are involved, and more of such contracts are in the pipeline. The M&V standard in public sector retrofits is set even higher at $\pm 0.03^{\circ}\text{C}$ end-to-end measurement uncertainty.

A list of accredited EPCs (Energy Performance Contractors)/ESCOs (Energy Services Companies) is available on the www.sgbc.sg and e2singapore.gov website respectively, which features both MNCs and local SMEs. Some of the EPCs/ESCOs maintain their own calibration labs; and some also offer performance guarantee through energy performance contracts with financing.

Since 2013, BCA has also started registering competent persons familiar with the M&V standards and practices under the BCA Energy Auditors Scheme. The list of Energy Auditors registered with BCA can be found in the following website http://www.bca.gov.sg/EnvSusLegislation/Registered_Energy_Auditors.html. The BCA Academy also conducts a regular course on Measurement and Verification of Central Chilled Water Plant Performance, more information is available on the website <http://www.bcaa.edu.sg/>.

Q6. Should I use Platinum RTDs (resistance temperature detectors) or thermistors for measuring the water temperature?

TEMPERATURE

The Green Mark standard is performance-based and technology-neutral. BCA accepts any measurement system that can provide a long term end-to-end temperature measurement uncertainty of $\pm 0.05^{\circ}\text{C}$.

Q7. What is the spare thermowell specification?

BCA's test probe used for site verification is 228mm long and 3.2mm in diameter. For proper insertion, the thermowell should have an open tip slightly larger than 3.2mm diameter, and the length of the assembly including isolation valve (if any) and the test plug should not exceed 200mm length. This would ensure that the test probe is in direct contact with the water.

BCA also accepts spare test plugs without thermowell as long as the test probe is able to come in direct contact with the water especially for pipes with larger diameter.

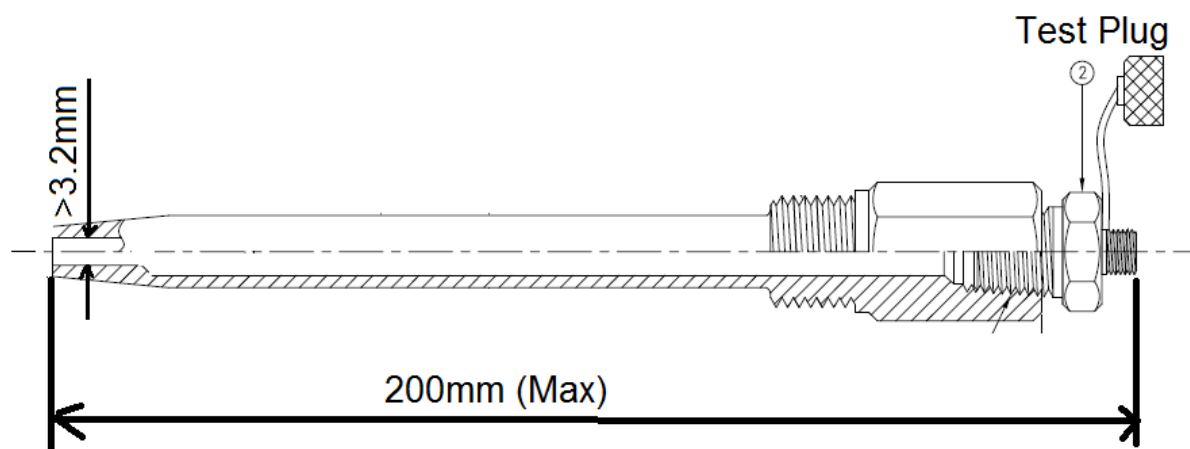

Q8. What is the requirement for Heat Balance?

The verification of chilled water plant instrument using the heat balance –substantiating test shall be in accordance to AHRI 550/590. The heat balance shall be conducted over the entire normal operating hours with more than 80% of the computed heat balance within $\pm 5\%$ over the audit period (1 week).

The computation formula is as follows:

$$\text{Percent Heat Balance} = \left| \frac{(q_{\text{evaporator}} + W_{\text{input}}) - q_{\text{condenser}}}{q_{\text{condenser}}} \right| \times 100\% \leq 5\%$$

where $q_{\text{condenser}}$ = heat rejected

$q_{\text{evaporator}}$ = cooling load

W_{input} = measured electrical power input to compressor

For open drive chillers, the W_{input} shall take into account the motor efficiency provided by the manufacturer. An example is provided as follows:

Input power (measured)	= 100kW
Motor rated efficiency (η)	= 90%

TEMPERATURE

$$\begin{aligned} \text{Adjusted } W_{\text{input}} &= 100\text{kW} \times 90\% \\ &= 90\text{kW} \end{aligned}$$

In the event where hydraulic losses of pumps constitute a substantial heat gain, these losses have to be properly accounted for. The value shall be determined from pump efficiency values provided by the manufacturer. An example is as follows:

$$\begin{aligned} \text{Motor input power (measured)} &= 30\text{kW} && \text{(A)} \\ \text{Motor rated efficiency } (\eta) &= 90\% && \text{(B)} \\ \text{Pump rated efficiency } (\eta) &= 80\% && \text{(C)} \\ \text{Hydraulic losses} &= (\text{A}) \times (\text{B}) \times (100\% - (\text{C})) \\ &= 30\text{kW} \times 90\% \times (100\% - 80\%) \\ &= 5.4\text{kW} \\ \text{Adjusted } W_{\text{input}} &= kW_i(\text{chillers}) + 5.4\text{kW} \end{aligned}$$

Q9. Is yearly calibration required for temperature sensors?

Yearly calibration is not required if the heat balance meet the requirement of within $\pm 5\%$ for 80% of normal operating hours. However, if the heat balance fails, it is an indication that some of the sensors have drifted. The project team has to investigate the possible cause, and may need to send the sensors for calibration.

POWER

Q10. What is the measurement accuracy of power meters required by Green Mark?

It stated in GM NRB: 2015 and GM ENRB: 2017 that the power meter and its current transformer (where applicable) need to be class 1 or better.

Q11. How many power meters are required to be installed under the Green Mark pre-requisite for permanent M&V instrumentation?

A minimum of four (4) power meters are required for each of the following groups of equipment:

- Chiller(s),
- Chilled water pump(s),
- Cooling Tower(s), and
- Condenser water pump(s).

Q12. What is the calibration requirement for power meter, metering current transformer?

Presently, type test reports from manufacturers are acceptable. Nevertheless, we strongly encourage the use of verified power meters, with individual test certificate prior to the installation of any power meter(s) and current transformer(s) in order to achieve the overall chilled water plant measurement accuracy.

FLOW

Q13. Is it difficult to achieve enough clearance of 5 pipe diameters upstream and 3 pipe diameters downstream to install the magnetic flow meter?

With proper planning of chilled water system, there is usually enough straight-length pipe clearance in the header or riser for proper installation of the flow meters.

Q14. Why does Green Mark recommend the use of magnetic flow meter?

Magnetic flow meter is recommended as it offers better long term accuracy, repeatability and reliability of the water flow measurement. The requirement for straight-length pipe clearance is also the least.

In the event that a magnetic flow meter installation is not feasible, a clamp-on ultrasonic flow meter (UFM) is the next best alternative. However, do note that scaling of the condenser water pipe over time may affect the accuracy of UFM's.

Q15. Can I install the ultrasonic flow meters at any point so long as the straight pipe length requirement is fulfilled?

No. In ultrasonic flow meter measurement, the mounting points should also be observed to avoid locations where air bubbles are likely to occur or bubbles are likely to trap. Please see illustrations below.

correct :



correct :



disadvantageous:

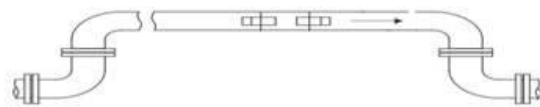

disadvantageous:

