

**Building Control (Amendment) Act 2012 and Regulations 2012:**

# **Geotechnical Building Works (GBW)**

## **– Submission Requirements**

**Building Engineering Group  
Building and Construction Authority  
March 2024**



# DISCLAIMER

Nothing contained in this circular is meant to replace or negate the need to comply with the provisions of the Building Control Act and building regulations in all aspects. QPs are to note that they have duties under the Building Control Act, amongst others, to take all reasonable steps and exercise due diligence to ensure that building works are designed in accordance with the provisions of the Building Control Act and building regulations.



# Content :

**1.General Definitions**

**2.What is geotechnical building works?**

**3.Submission requirements for ERSS**

**4.Examples of GBW (Excavation Works)**

**5.Examples of GBW (Tunneling Works)**

**6.Examples of GBW (Foundation Works)**

**7.Examples of non-GBW**



# General Definitions

- **Geotechnical Aspects**

- An analysis of the geological structure and earth materials of the site of the geotechnical building works and its influence on the geotechnical building works
- An analysis of the ground-water regime and its influence on the wall stability and integrity of the geotechnical building works over time; and
- Such other applications of earth sciences to and engineering aspects of the geotechnical building works as may be prescribed

- **Earth Retaining Structure**

- Any structure, structural system or other means used to maintain the shape of excavation during construction, earth filling or cutting



# General Definitions

- **Geotechnical Engineer, PE(Geo)**
  - A professional engineer who is registered under the Professional Engineers Act (Cap. 253) as a specialist professional engineer in the specialised branch of geotechnical engineering
- **Specialist Accredited Checker, AC(Geo)**
  - An accredited checker who is registered under section 16 to undertake the work of an accredited checker as regards the geotechnical aspects of any geotechnical building works



# General Definitions

- **Tunneling Works**

- Any excavation or other building works to make a tunnel with a diameter, width or height or more than 2 m

- **Excavation Works and Earth Retaining Structures**

- Any excavation, or other building works to make a caisson, cofferdam, trench, ditch, shaft , well with a depth of more than 6 m
- Any building works for constructing, altering or repairing any earth retaining structures in or for a trench, ditch, shaft, well with a depth or height or more than 6 m
- Any earthwork or other building works for constructing or stabilising a slope with a height of more than 6 m (measured as vertical distance between the highest level to the lowest level of the slope)

- **Foundation Works**

- Foundation for buildings of 30 or more storeys



## Submission Requirement for ERSS

| All permanent or temporary building works that involve   | Appointments Required         |                         |
|--|-------------------------------|-------------------------|
|  | Qualified Person (QP)         | Accredited Checker (AC) |
| Excavation/ERSS $\leq$ 1.5 m** deep  | Plan approval is not required |                         |
| 1.5 m** < Excavation/ERSS $\leq$ 4 m deep  | QP(ST)                        | AC is not required      |
| 4 m < Excavation/ERSS $\leq$ 6 m deep  | QP(ST)                        | AC                      |
| Excavation/ERSS > 6 m deep and not classified as GBW: e.g. excavation for sewer manhole associated with pipe diameter of 2 m or less | QP(ST)                        | AC                      |
| Excavation/ERSS > 6 m deep and classified as GBW. E.g. basement excavation.  | QP(ST)<br>QP(Geo)             | AC<br>AC(Geo)           |

**Notes:**

Plan approval is not required for insignificant building works listed on First Schedule of Building Regulation 3A.

\*\* If the structure that retains earth is not constructed of reinforced concrete or steel, then the applicable depth is 1 m instead of 1.5 m.

Planning approval is no longer required for any retaining wall or earth-retaining structure for supporting the face of an excavation made for the purpose of constructing any pile cap, footing, sump, lift pit or trench, provided that the size of these structures does not exceed 10 square meters in area and 2 meters in depth.

# GBW – Submission Requirements

## Plans Submission

### (a) Plans approval is required for GBW

- To attach ERSS\_Annex A
- To include site investigation report with PE certification

### (b) Require Permit to commence work

- Commencement of work: to notify BCA

## During Construction Stage

- To implement ERSS\_Annex C at site
- To submit ERSS\_Annex E via e-form to CORENET before 7<sup>th</sup> monthly



# Advisory Note 1/09 on ERSS

Key points

Movement control limit

**Table 1: Allowable maximum ERSS wall deflection limits**

| Wall deflection limits/Zones<br>where<br>x = distance from excavation face;<br>H = excavation depth<br>$\delta_w$ = wall deflection | Locations of buildings, structures and critical utilities |                                   |                         |               |
|---|---|-----------------------------------|-------------------------|---------------|
|   | Zone 1<br>( $x/H < 1$ )                                   | Zone 2<br>( $1 \leq x/H \leq 2$ ) | Zone 3<br>( $x/H > 2$ ) |               |
|   |   |                                   | Ground Type A           | Ground Type B |
| Allowable maximum ERSS wall deflection limits ( $\delta_w/H$ )  | 0.5%  | 0.7%                              | 0.7%                    | 1.0%          |

Ground Type A refers to over-consolidated stiff clays and silts, residual soils, and medium to dense sands; and Ground Type B refers to soft clays, silts or organic soils extending to or below formation level (e.g. Kallang Formation) and loose fills.

10 In any case, the allowable wall deflection limits shall also be determined by the prevention of structural damage to neighbouring buildings or structures arising from ground deformations.

**Table 2: Control strategies guides for ERSS.**

| Zone 1        | Allowable limits |                                 |                                 |
|---------------|------------------|---------------------------------|---------------------------------|
|               | Alert level      | Work suspension level           |                                 |
|               | 70% WSL          | Allowable wall deflection limit |                                 |
| Zones 2 and 3 | Allowable limits |                                 |                                 |
|               | Check level      | Alert level                     | Work suspension level           |
|               | 50% WSL          | 70% WSL                         | Allowable wall deflection limit |

Critical limit

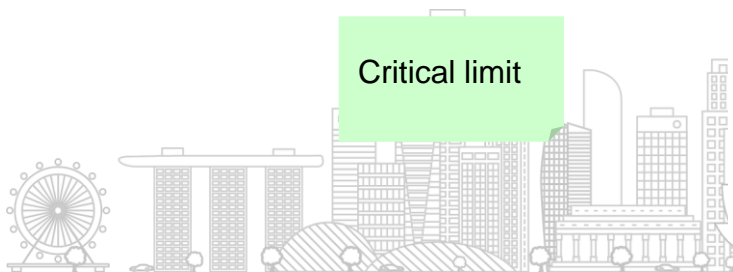

## Use of Ground improvement within retaining wall

- In view of uncertainty in using ground improvement, ground improvement shall be limited to soil improvement work only and shall NOT be used as part of retaining wall especially acting as cantilever retaining wall. This is in line with COI report and BCA's Advisory Note 1/09.
- If grout mixed piles are present within the retaining wall, as a minimum the following conditions shall be met:
  - a) all wall forces such as bending moments and shear forces shall be resisted by a separate structure system (such as soldier piles steel section inserted within the grout mixed pile, a separate analysis for obtaining wall forces shall be carried out with steel section only with grout mixed piles ignored in this analysis)
  - b) separate structural laggings (concrete, timber, or steel) shall be provided between structural wall member.



# Appointment of QPs and ACs

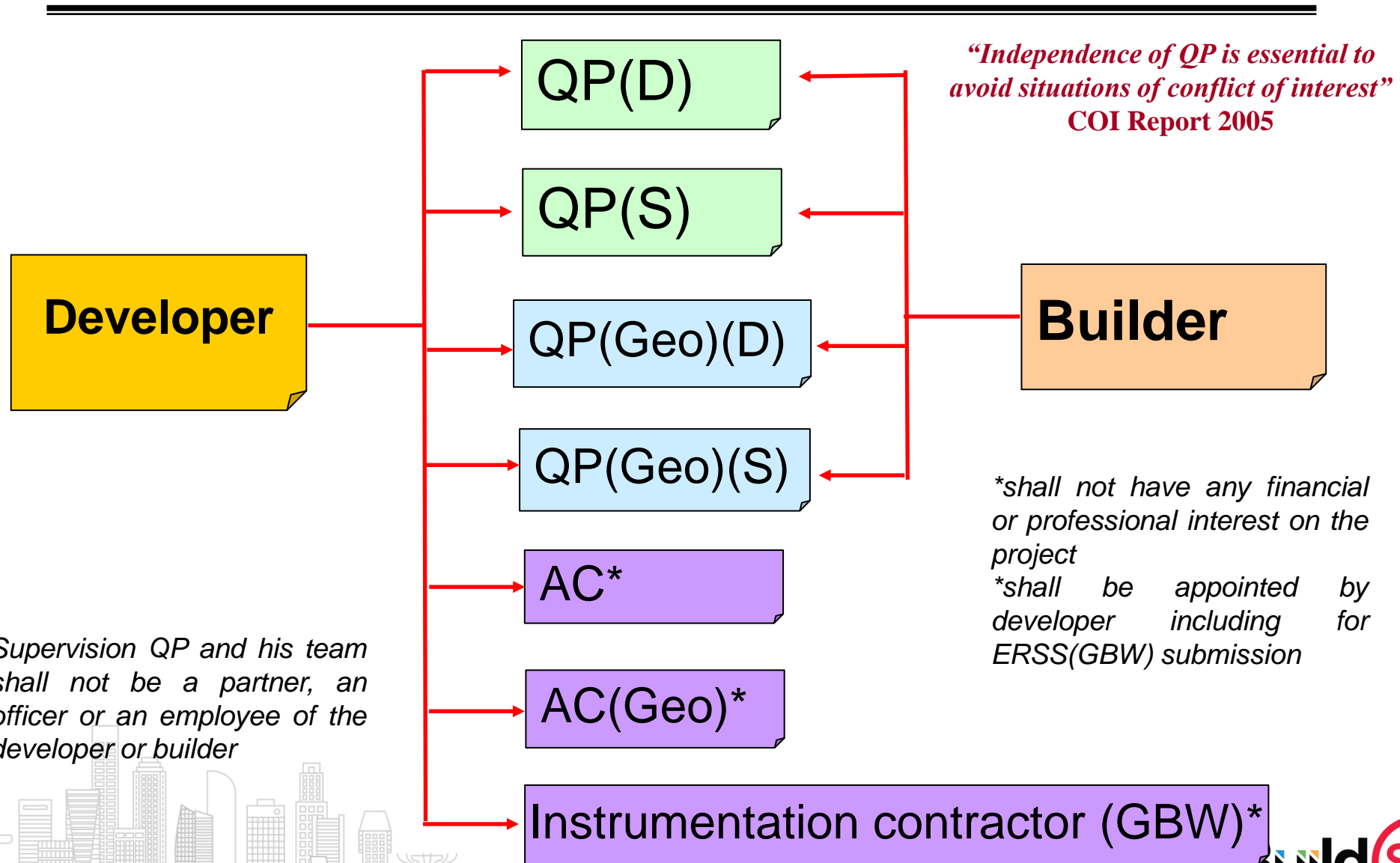

# Examples of Geotechnical Building Works (Excavation/earth retaining structures)



# Basement Excavation Works: Open cut method

## Single tier open cut slope

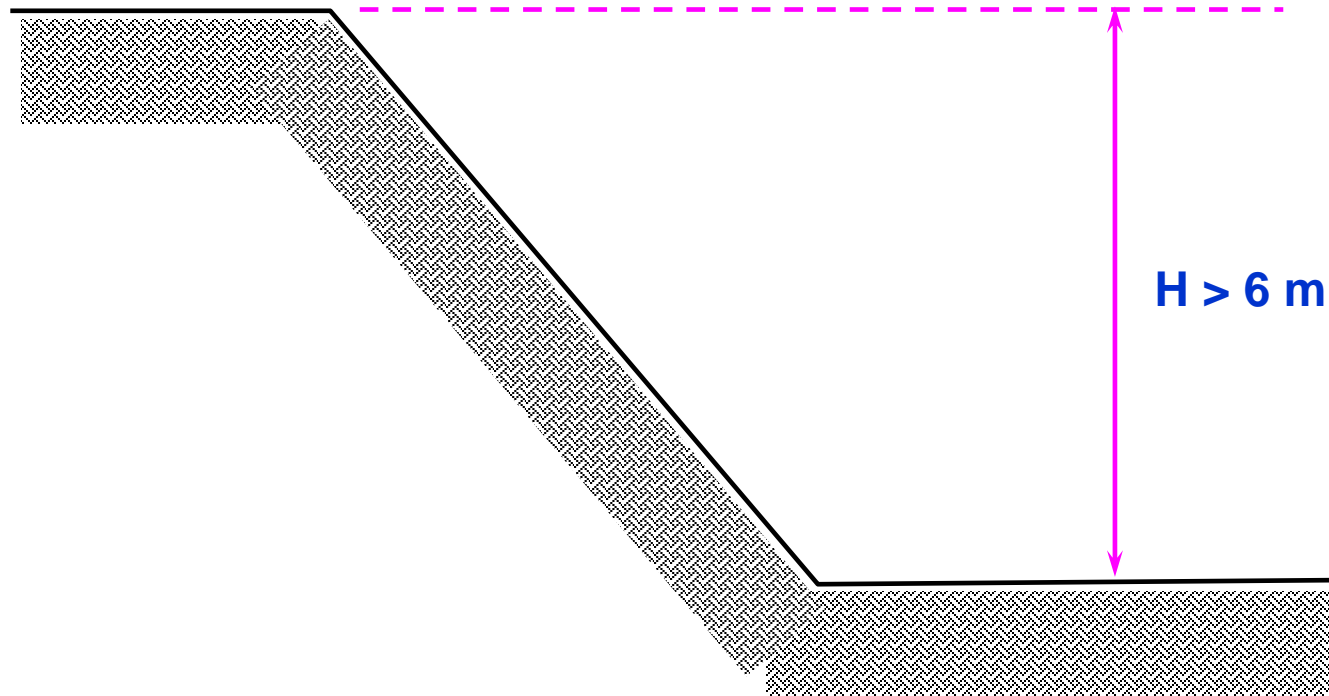

GBW



# Basement Excavation Works: Open cut method

## Multi-tier open cut slope in hard soils

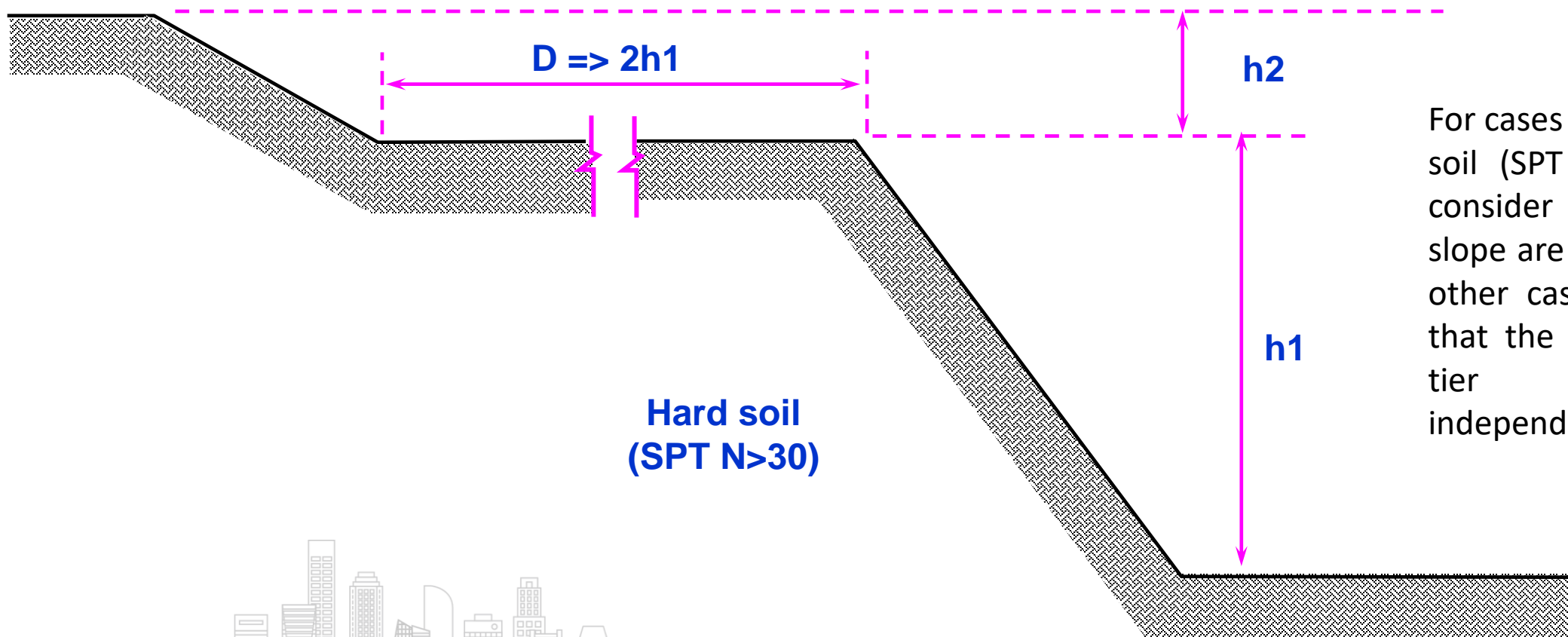

For cases  $D \Rightarrow 2h_1$  & in hard soil (SPT  $N > 30$ ), QP may consider the two tier of slope are independent. For other cases, QP to justify that the upper and lower tier slopes are independent.



# Excavation Works: Earth Retaining System

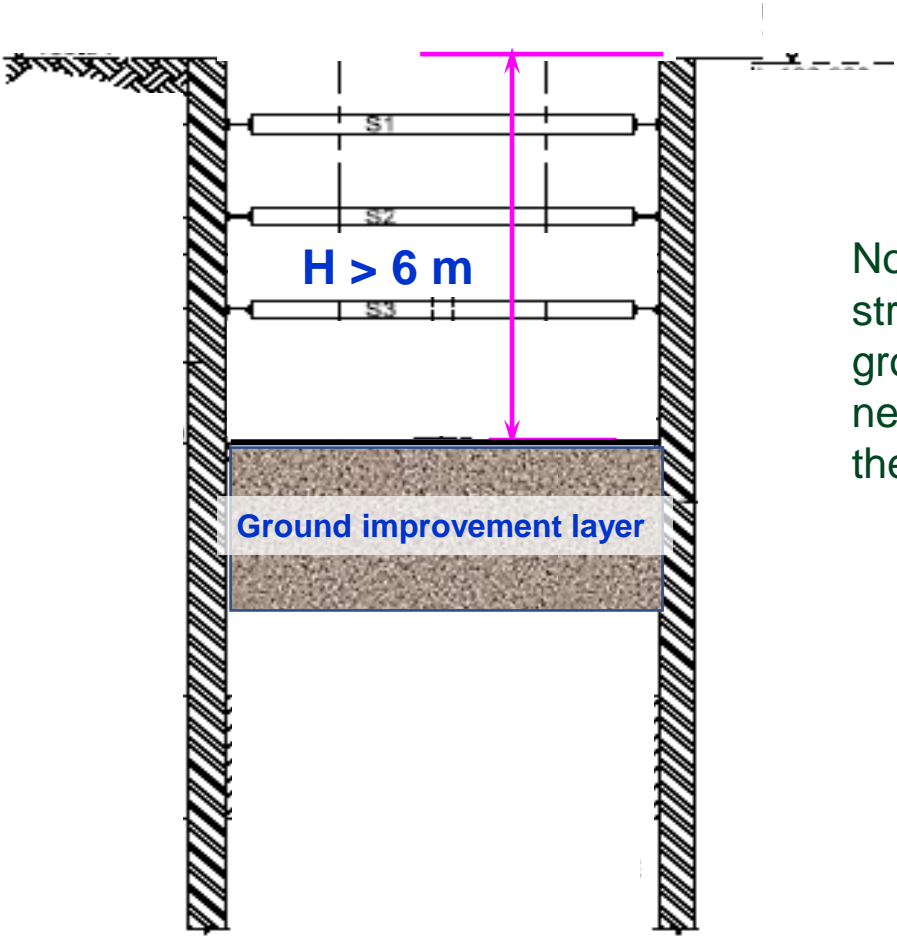

Note: Besides retaining wall and strutting supporting system, ground improvement layer is also need to be submitted as part of the GBW(ERSS) system.

GBW



# Excavation Works in sloping ground

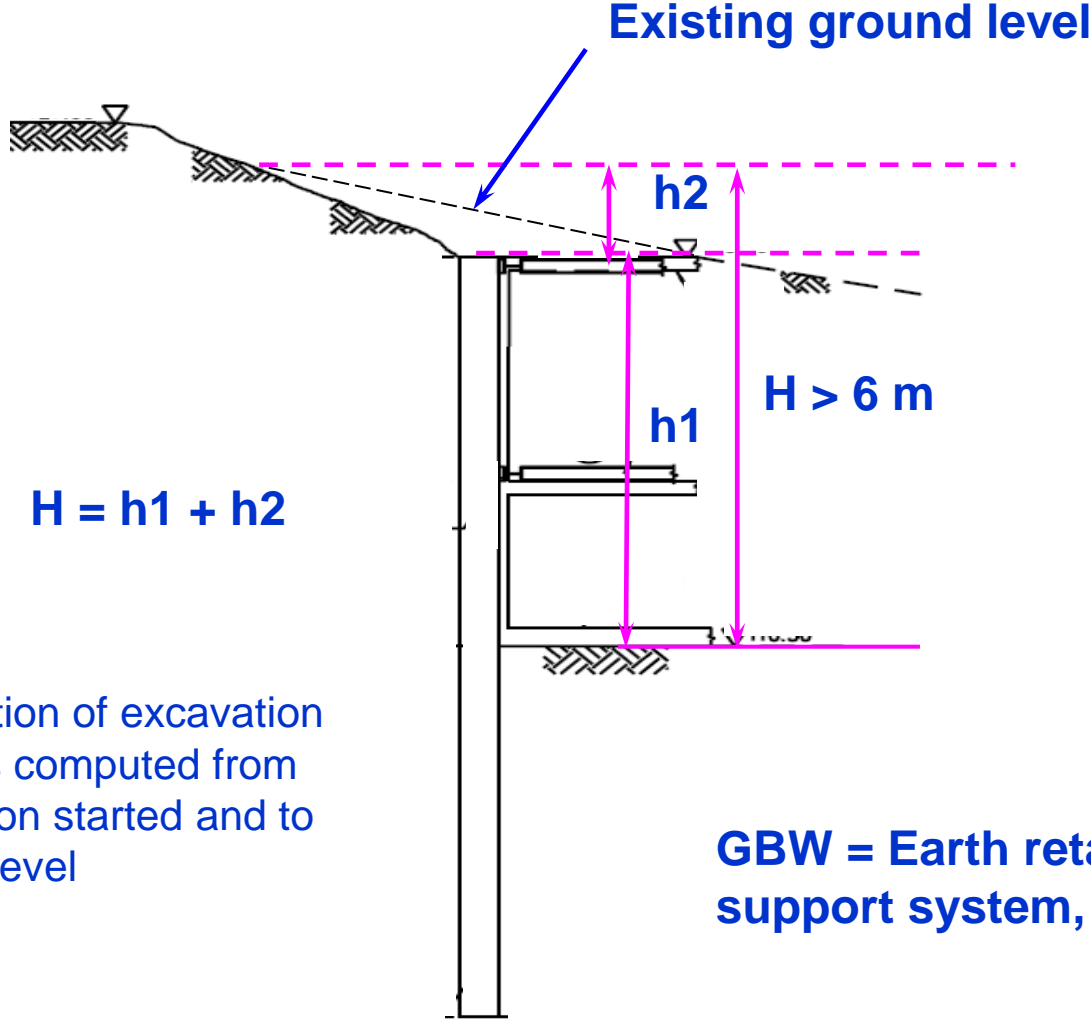

Note: For computation of excavation depth of GBW, H is computed from where the excavation started and to the final formation level

**GBW = Earth retaining & support system, slope**



# Excavation Works in sloping/varying ground

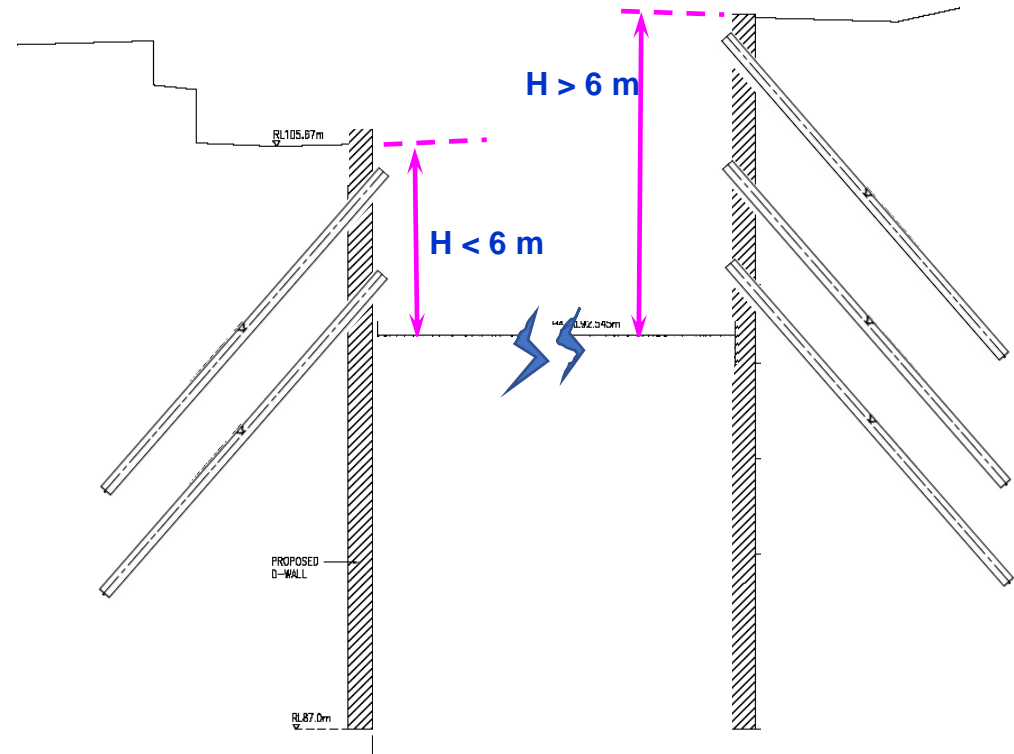
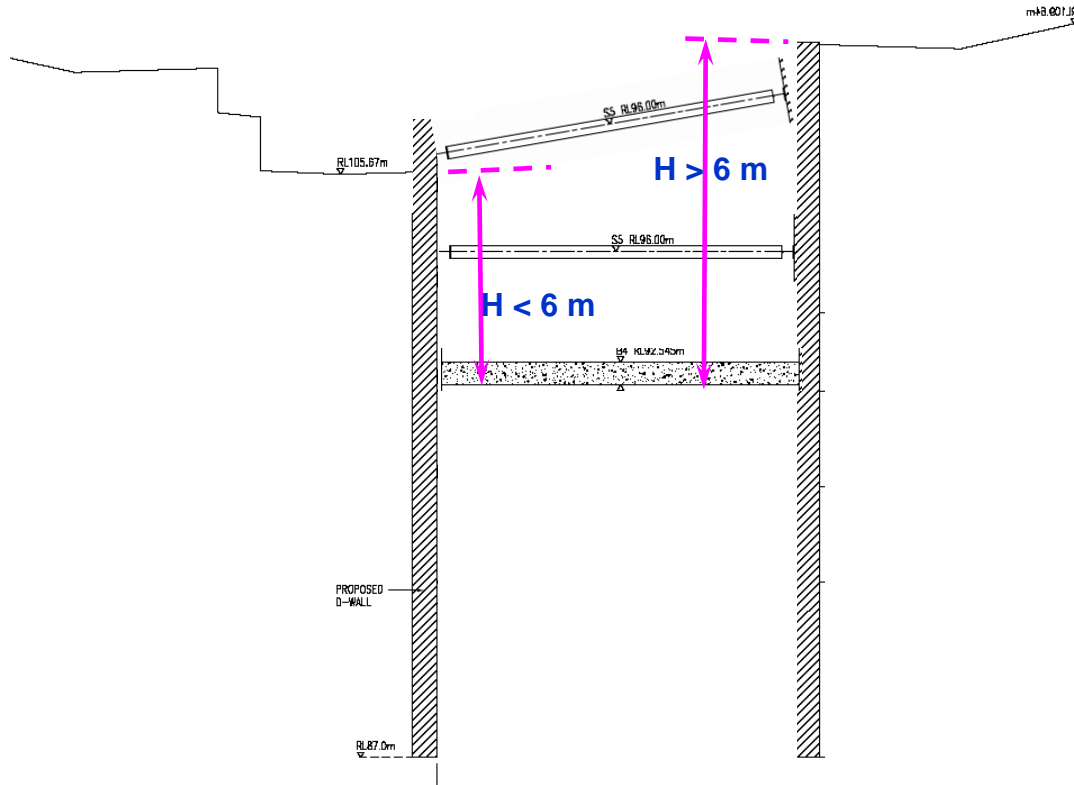

**GBW = Earth retaining & support system**

**Non-GBW**

**GBW**



# Excavation Works: Basement Construction

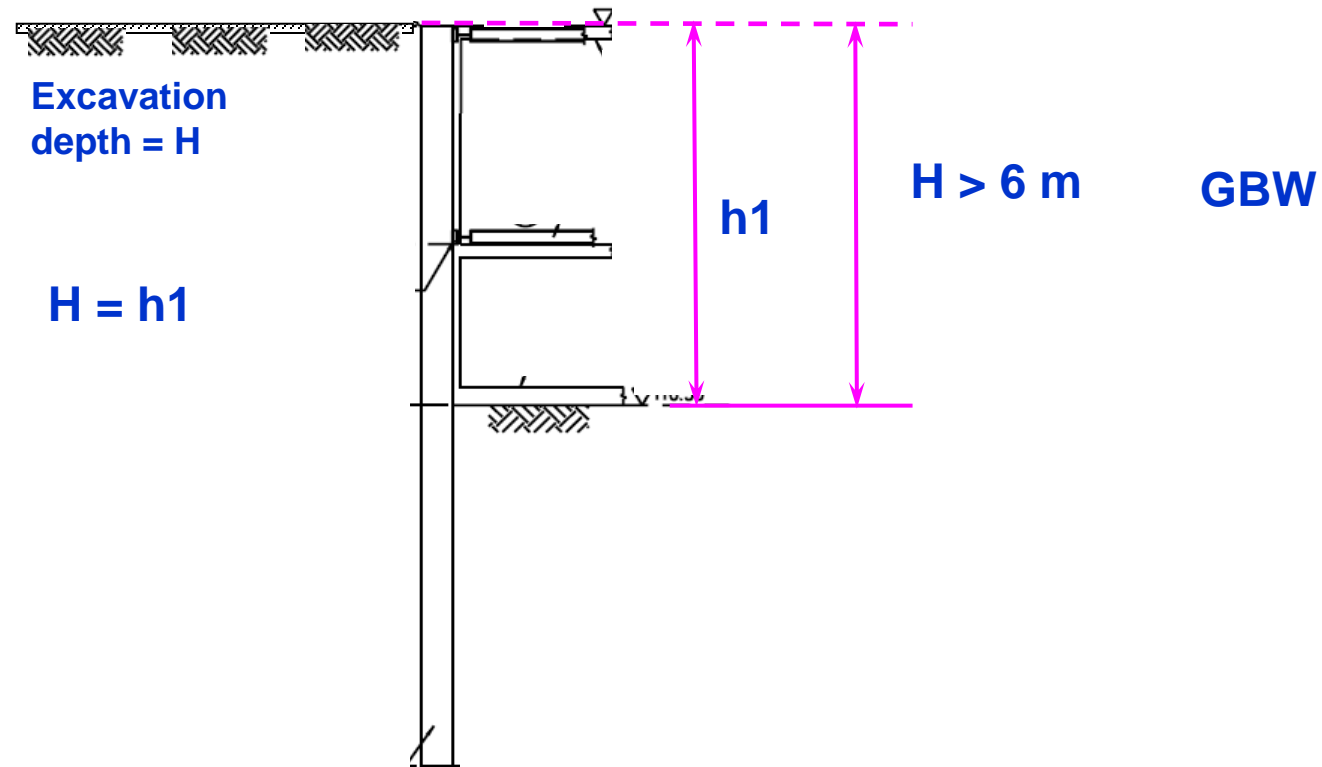

# Excavation Works: Basement Construction

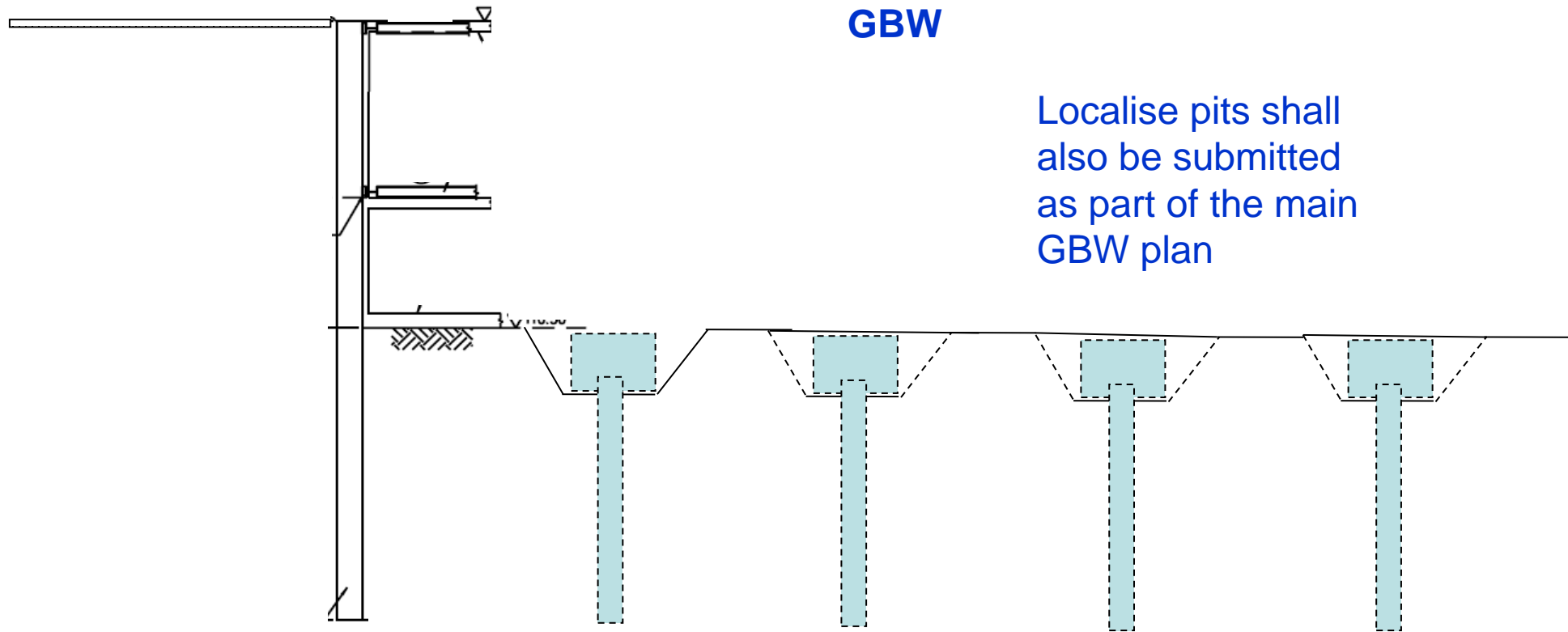

# Excavation Works: Construction of Basement structures

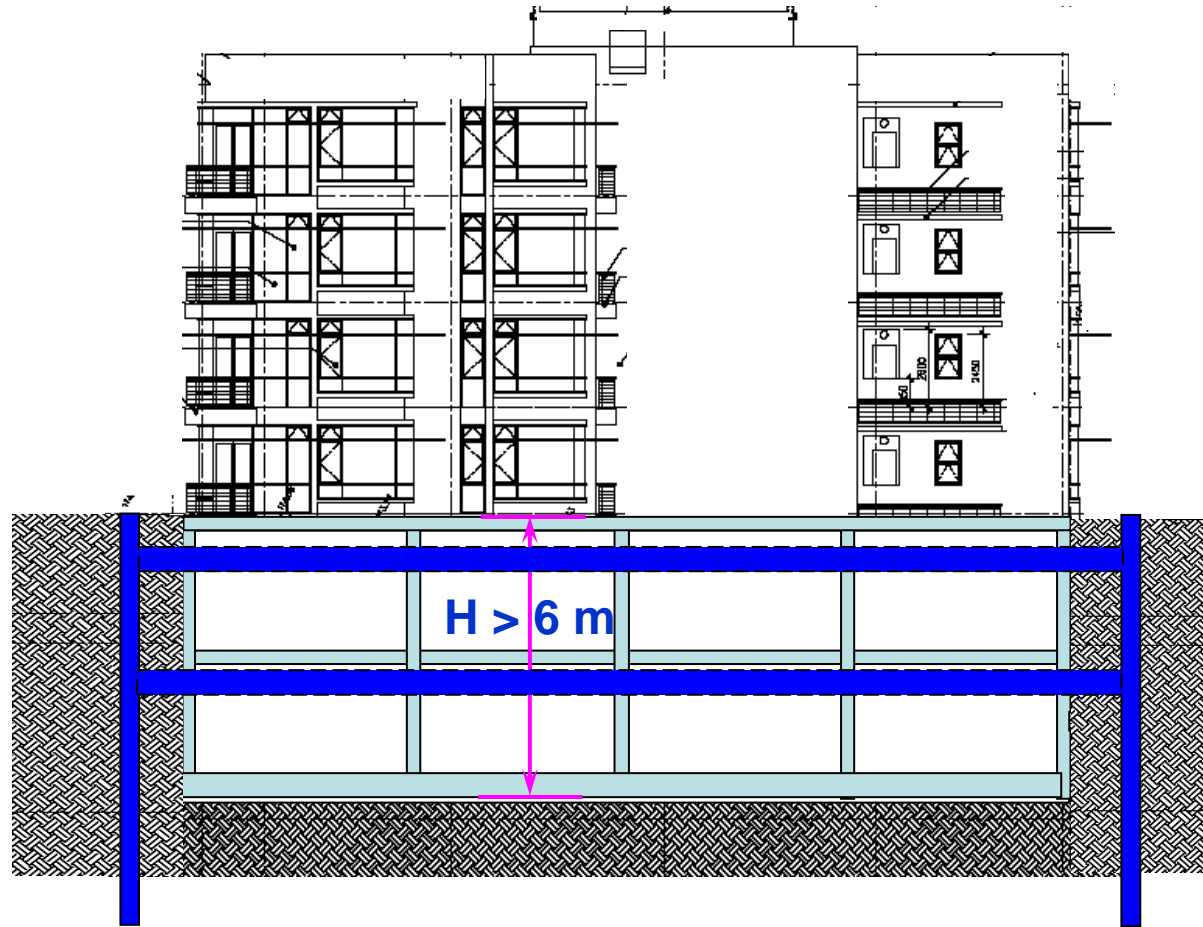

GBW = Temporary earth retaining & support system

Basement structures which is within the excavation support system, is not GBW



# Excavation Works: Construction of Basement structure

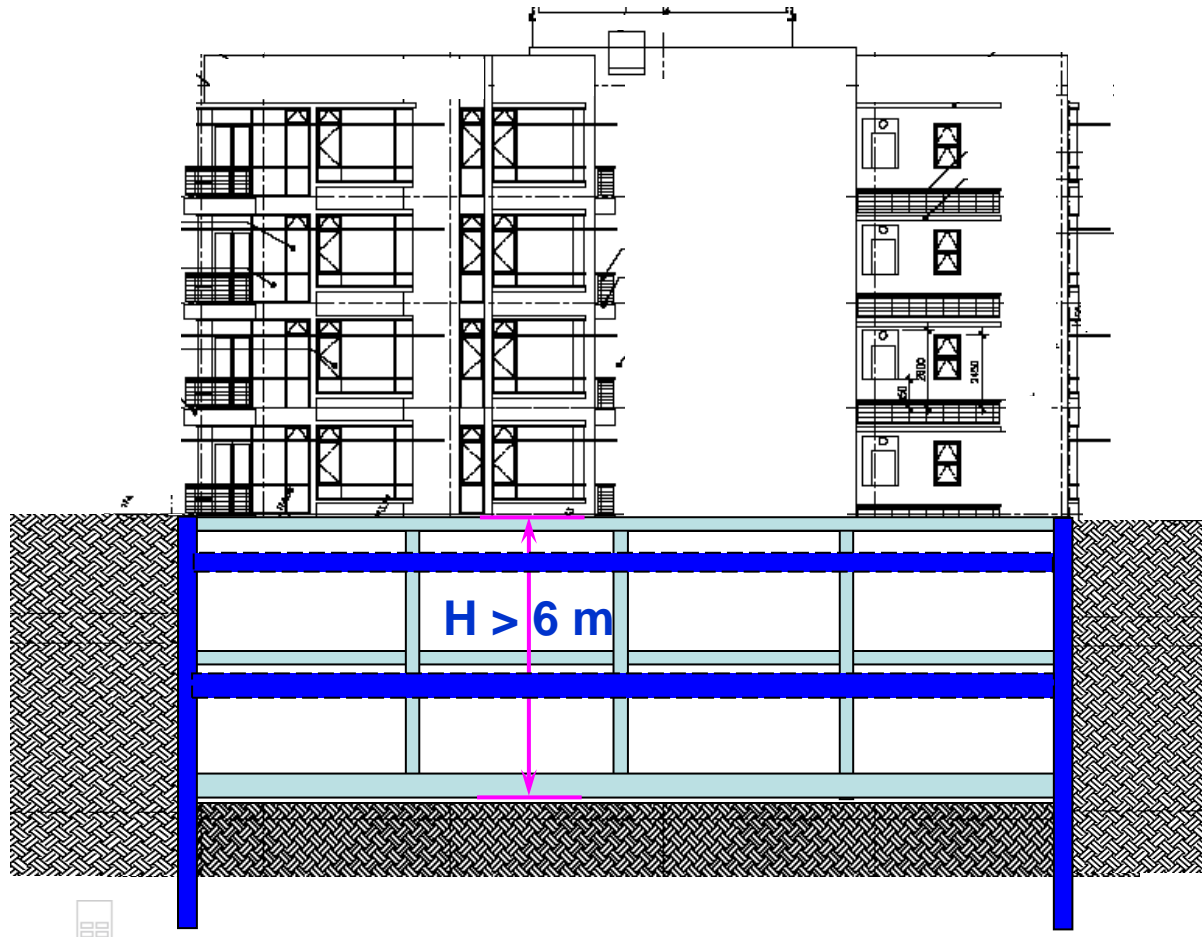

Note:

a) The plan submission for the temporary retaining wall and permanent basement structure shall be submitted under the same ST and to be submitted as GBW (not submit as piling)

As temporary retaining wall also serves as permanent retaining system of basement structure, GBW = Temporary and permanent earth retaining & support system including basement slab

# Excavation Works: Drainage Works

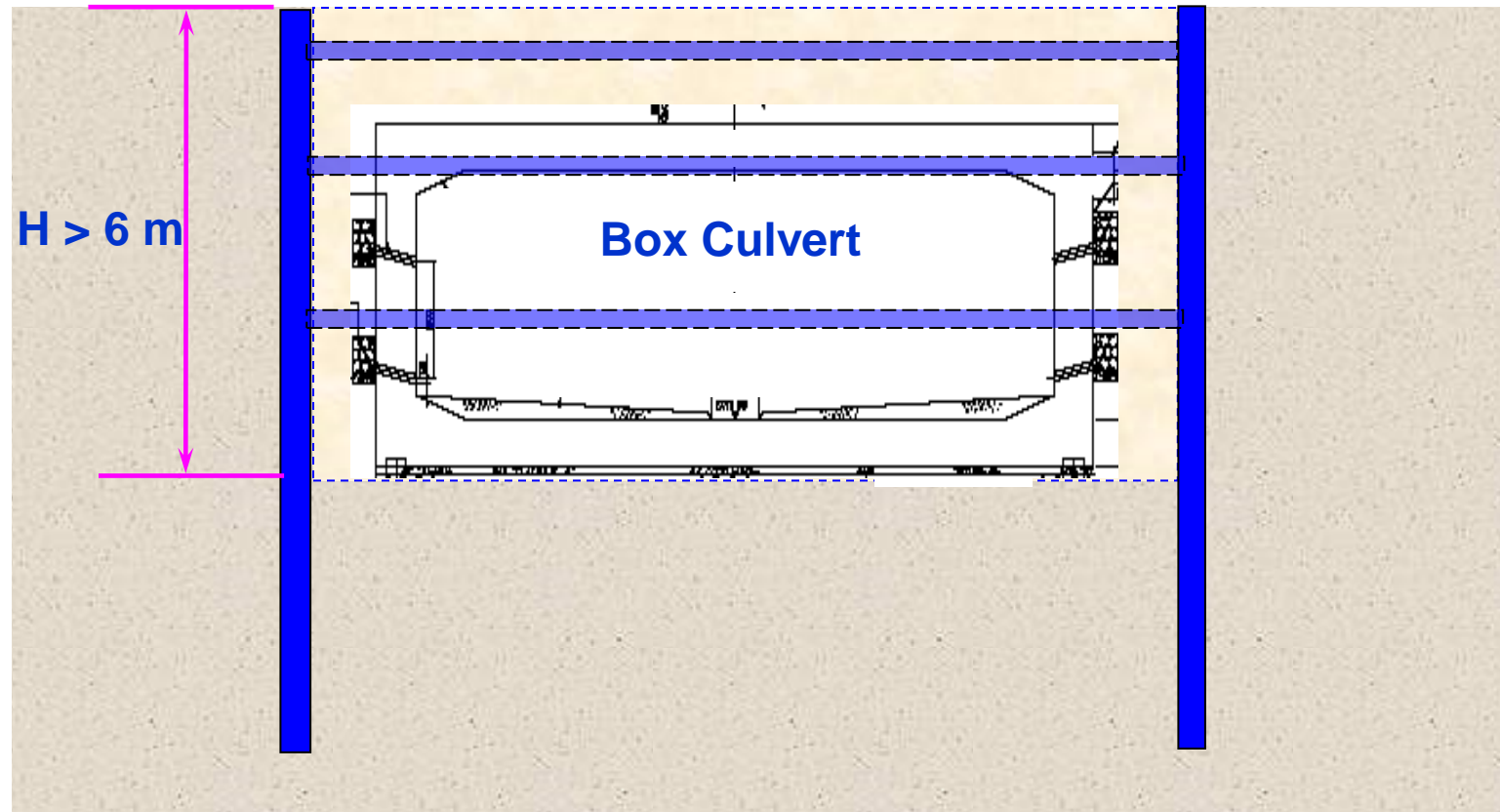

GBW = Temporary earth retaining & support system

Box culvert which is within the excavation support system, is not GBW



## Slope: A & A of existing slopes

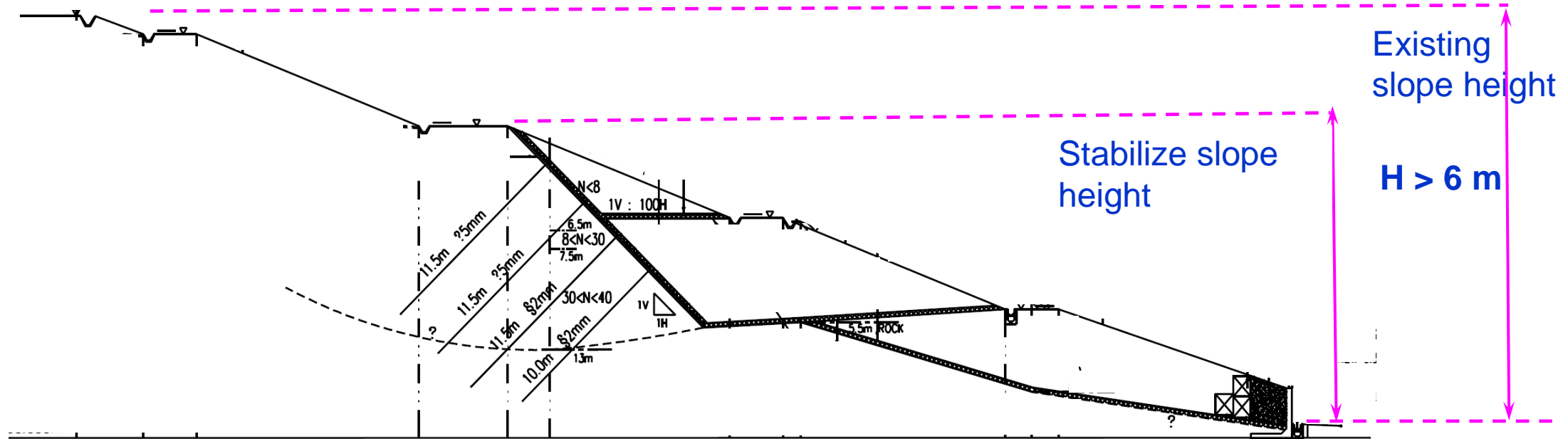

For A&A to slope or reinforcing or strengthening works affecting global stability of existing slope materially, QP and AC are required for plan submission if the affected existing slope height exceed 4 m. If the affected existing slope height exceed 6 m, QP(Geo) and AC(Geo) are also required for plan submission.

Plan submission is required for both temporary and permanent stages of ERSS(GBW)



# Independent retaining wall retaining with constructed slope

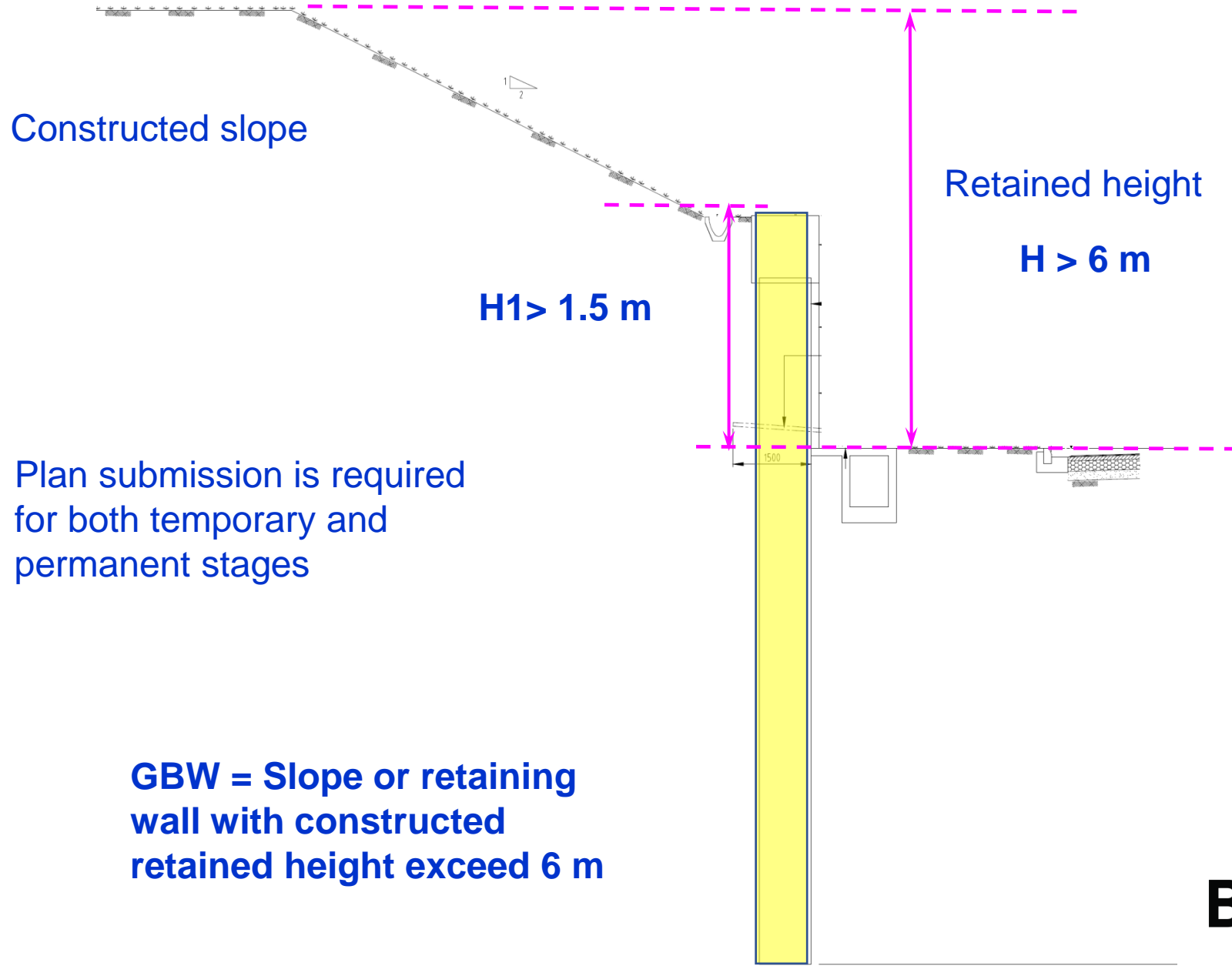

# Earth Retaining Structures (retaining existing slopes/high ground)

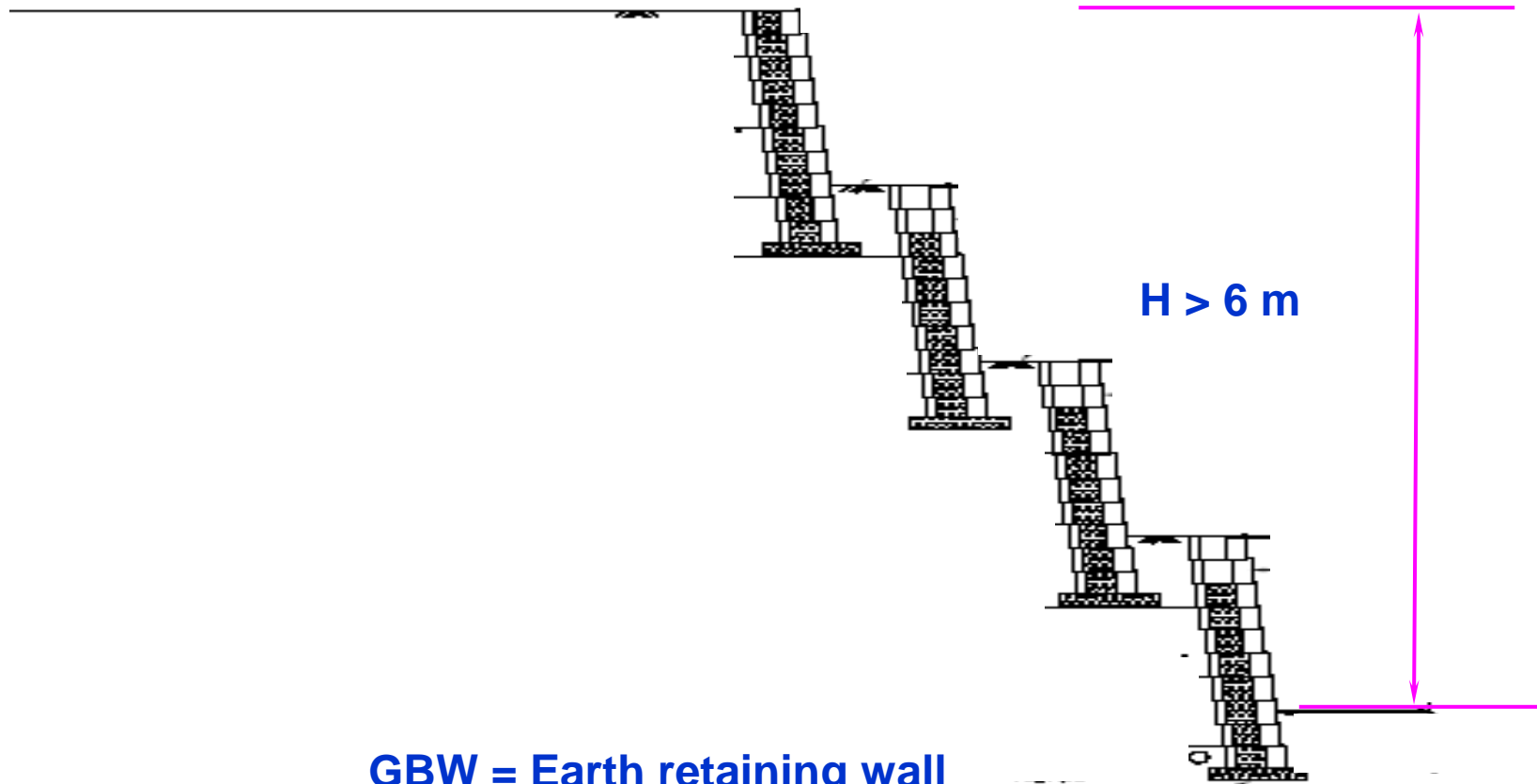

**GBW = Earth retaining wall**



# Earth Retaining Structure: Retaining wall

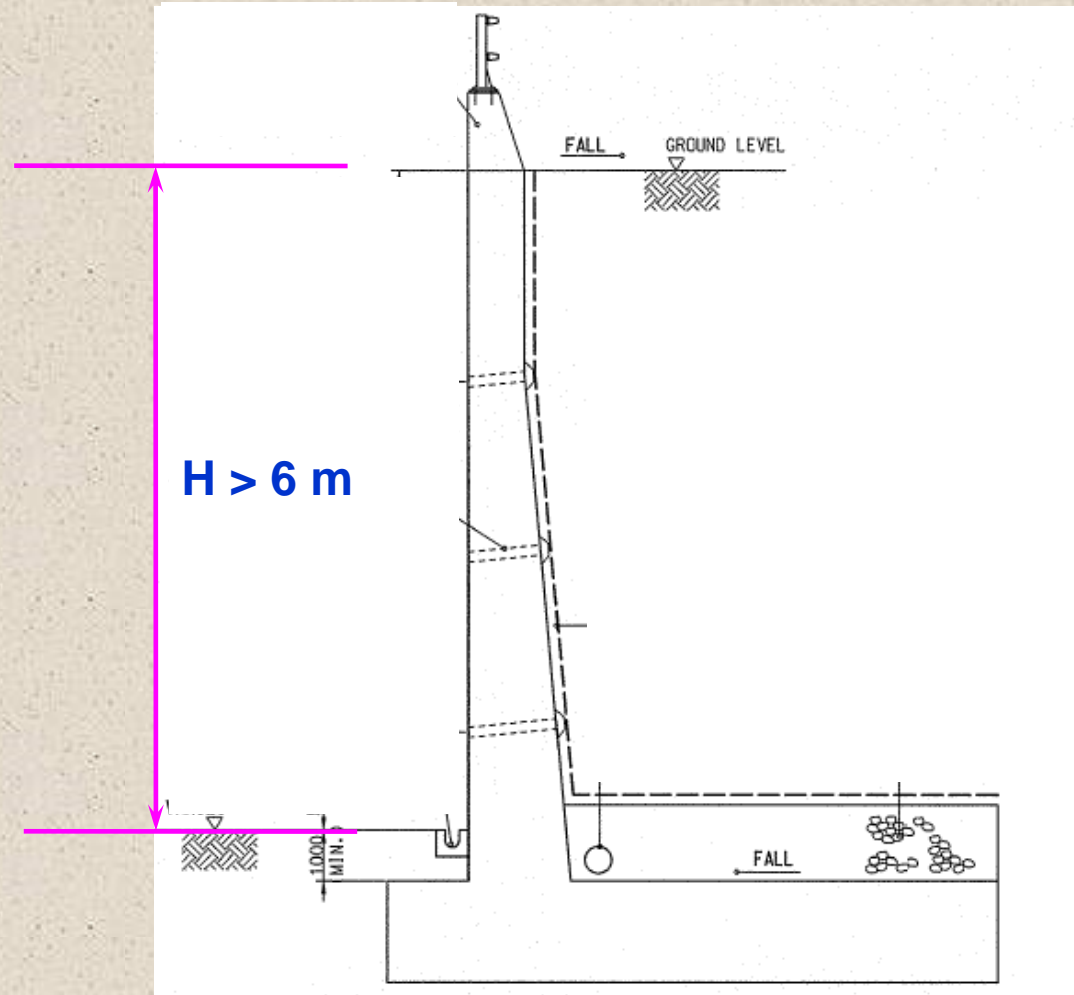

GBW = Earth retaining wall



# Earth Retaining Structure: Road Abutment

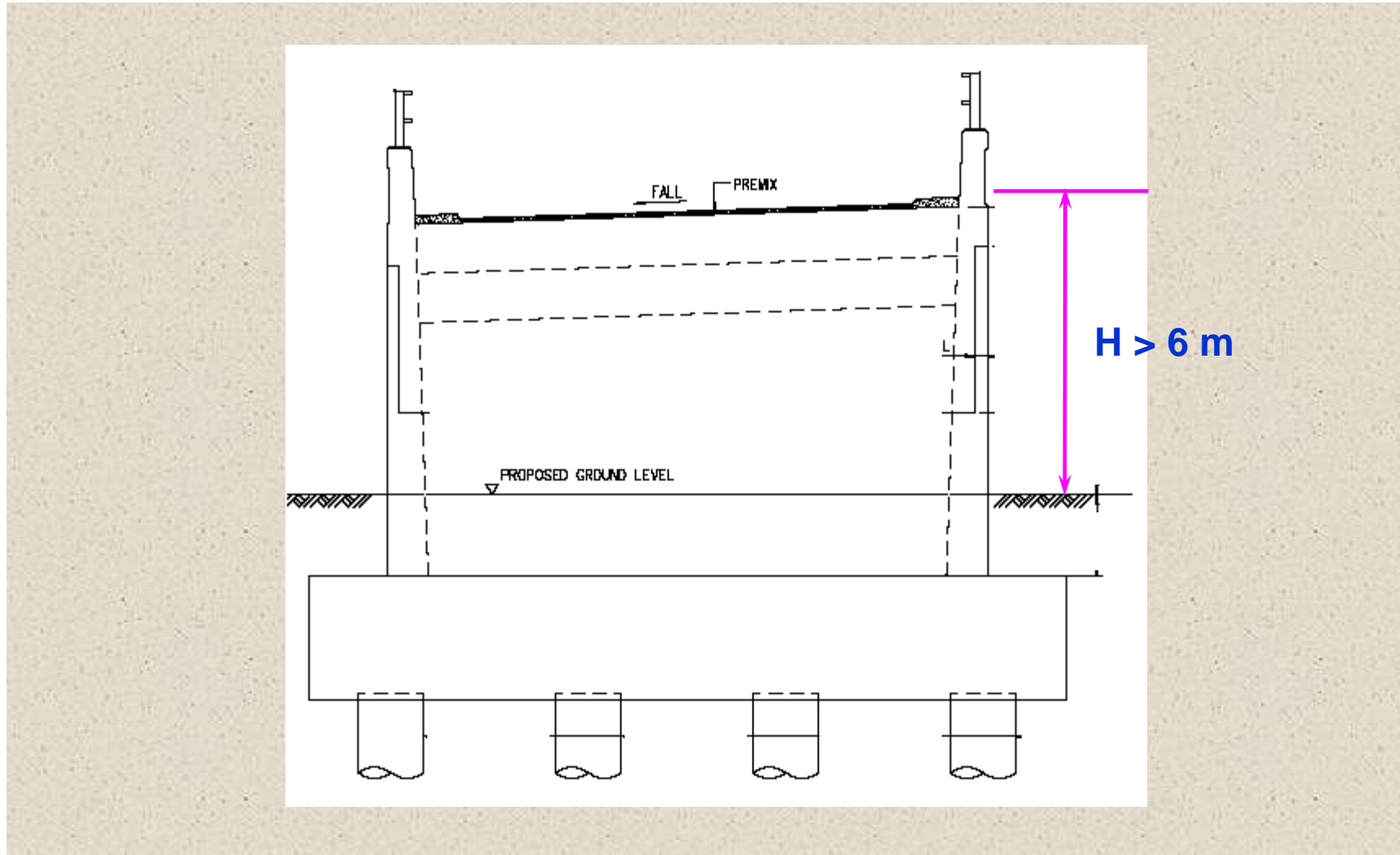

GBW = Road abutment



# Earth Filling Works: Embankment/Dam

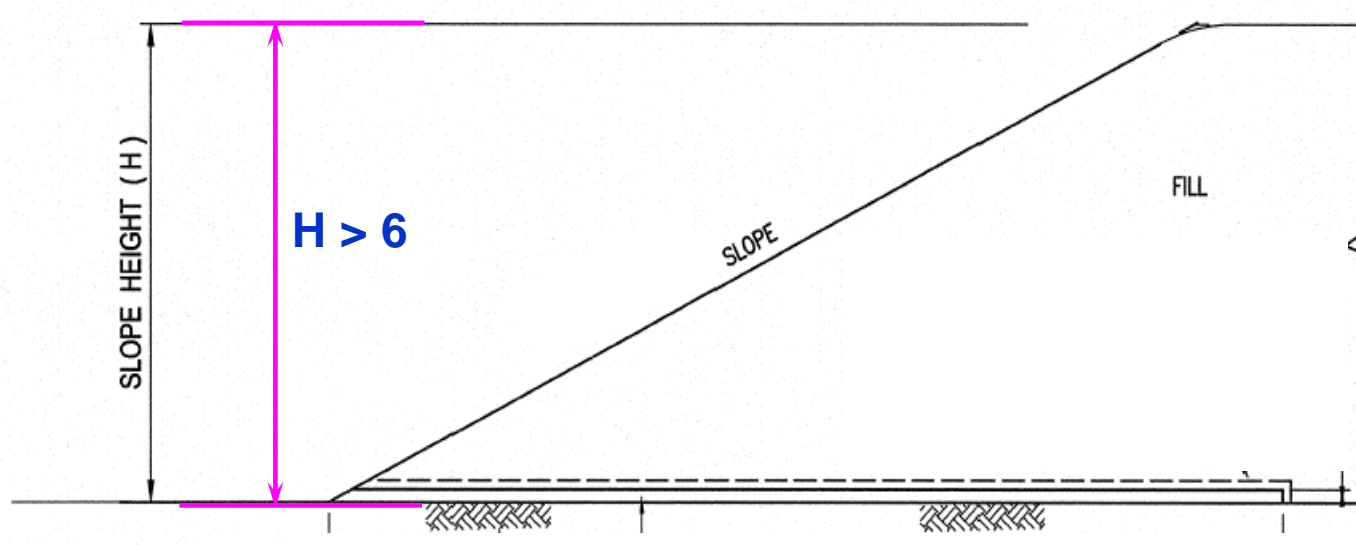

**GBW = Earth embankment/dam**



# Earth Filing Works: Retaining Walls

GBW = Caisson

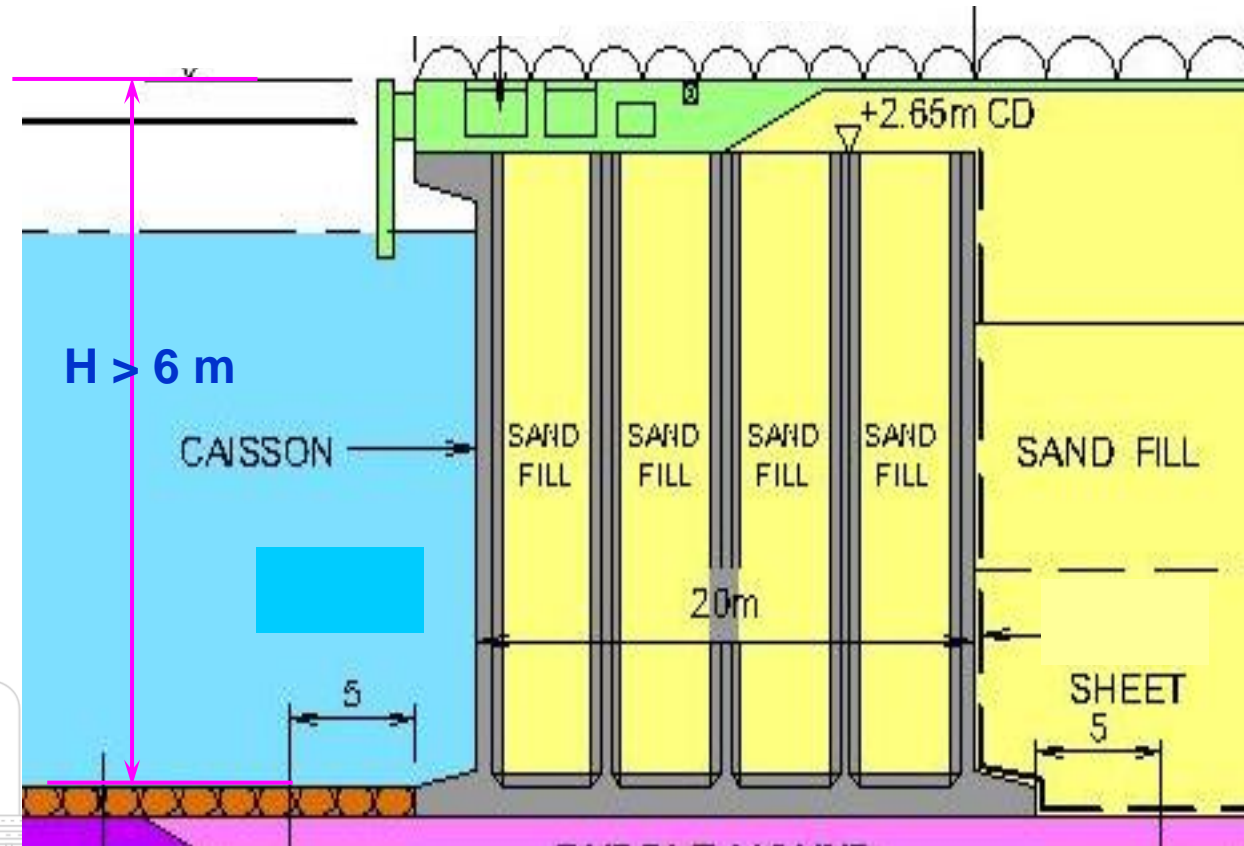

# Excavation Works: Utilities pipes (such as sewers, water and gas pipes) with diameter larger than 2 m and its associated shafts or manholes

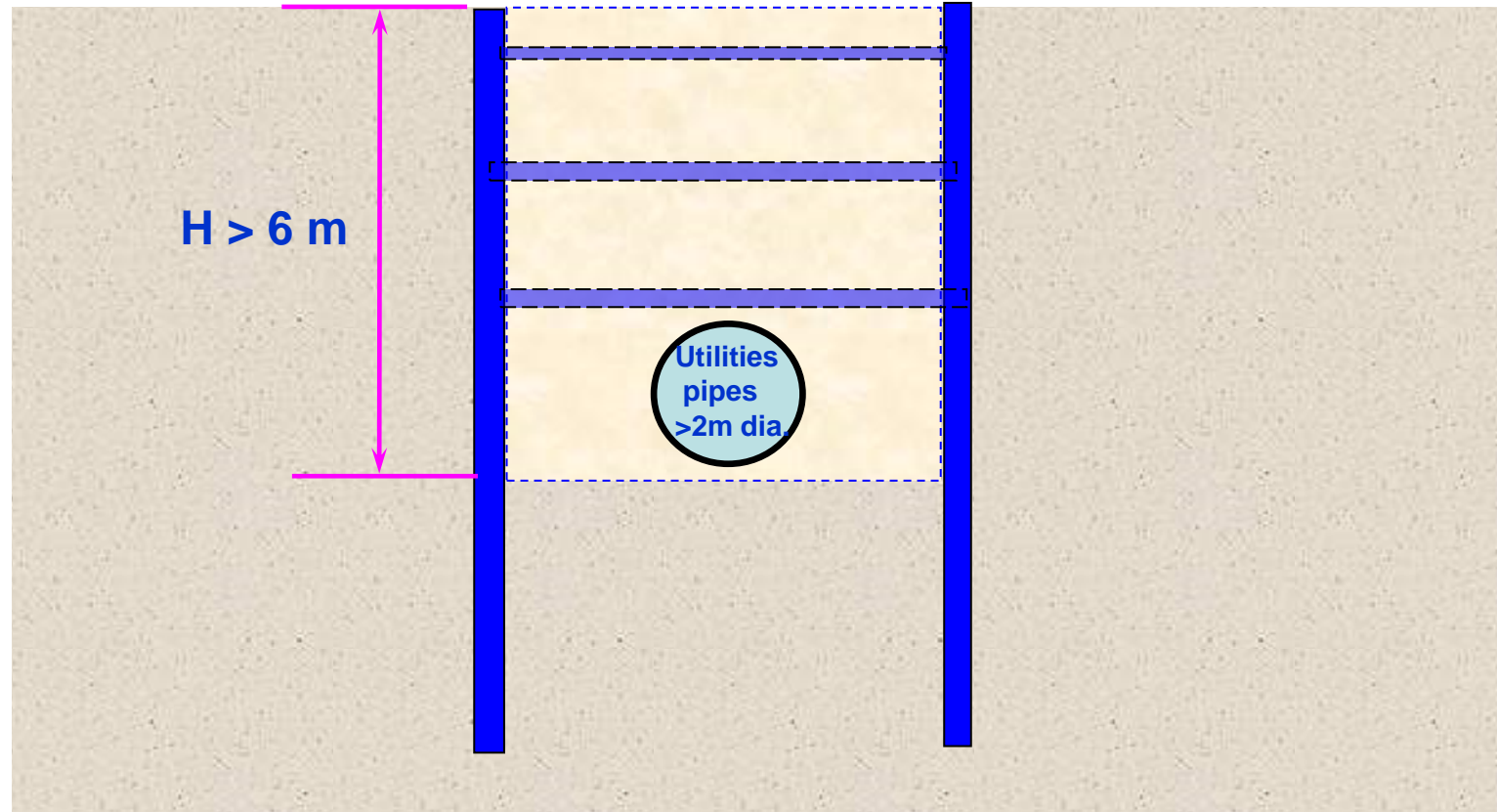

**GBW = Temporary earth retaining & support system**

**Utilities pipes or manholes which is within the excavation support system, is not GBW**



# Examples of Geotechnical Building Works (Tunneling Works)



# Tunneling Works: Bored Tunnels/Jacked-in tunnel

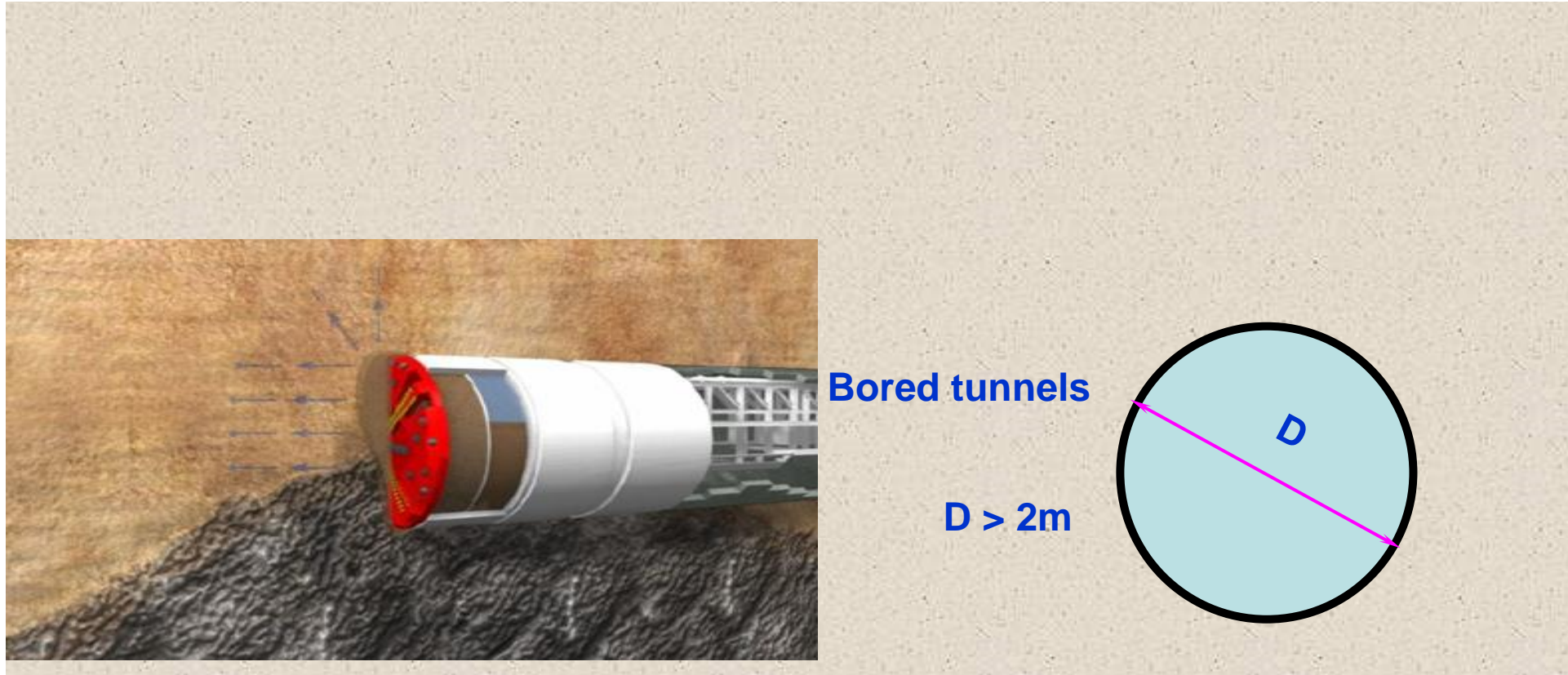

**GBW = Permanent (tunnel lining) and temporary tunnel support system**



# Tunneling Works: Cut-and-cover Tunnels

## Cut-and-cover tunnels

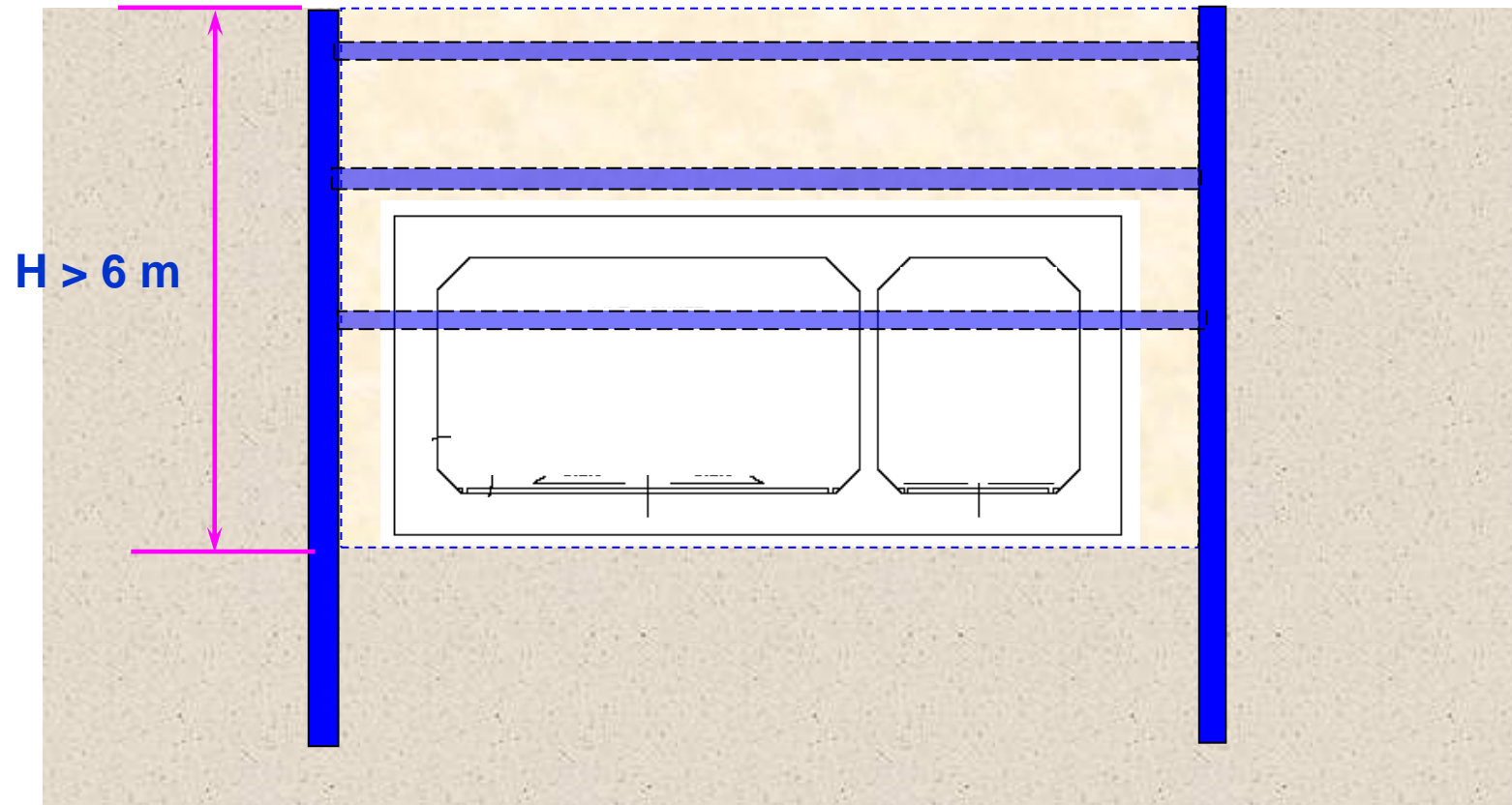

**GBW = Temporary earth retaining and support system**

**Permanent tunnel structure exceeding 2 m in diameter, width or height is also GBW**



# Tunneling Works: Mined Tunnel

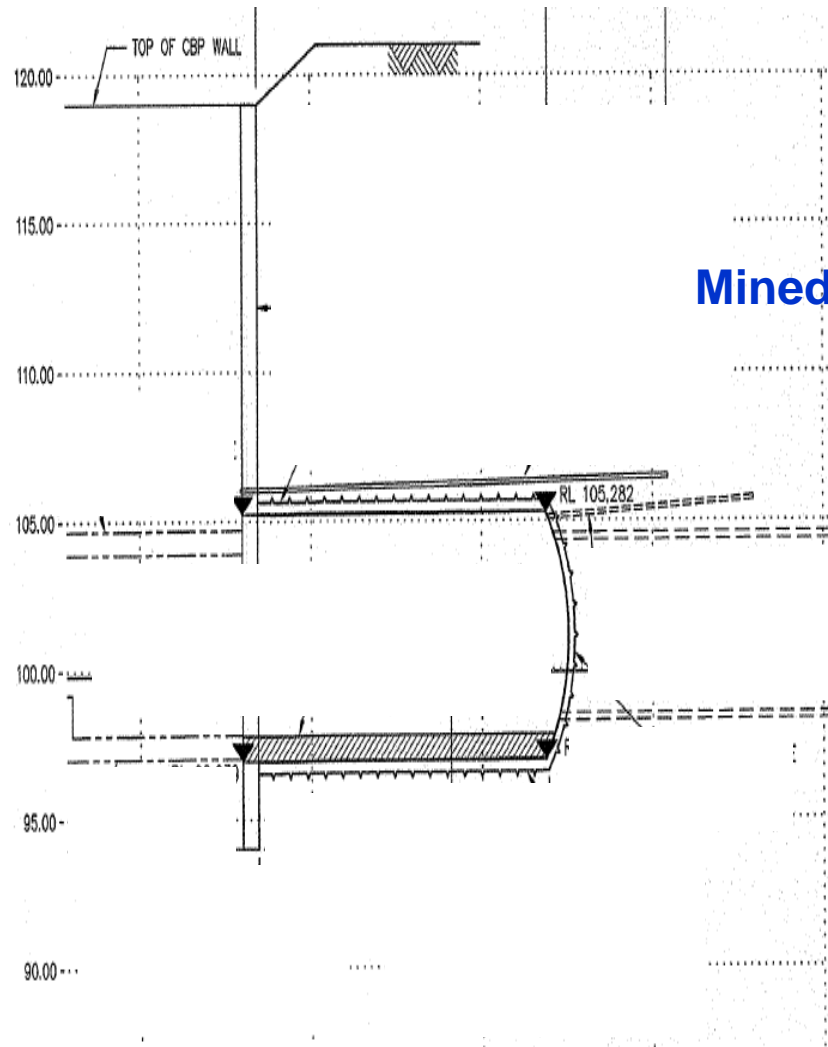

Mined tunnel

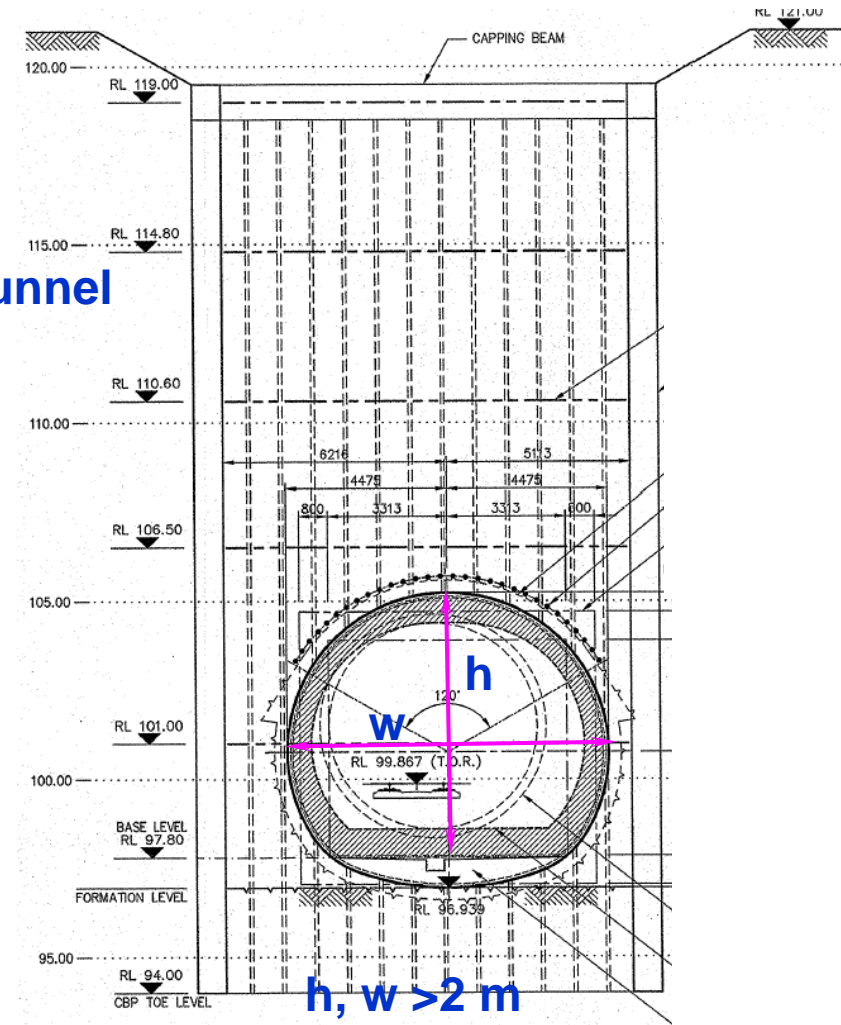

GBW = Temporary tunnel support system

Permanent tunnel structure exceeding 2 m in diameter, width or height is also GBW



# Examples of Geotechnical Building Works (Foundation Works)



# Foundation of High-rise

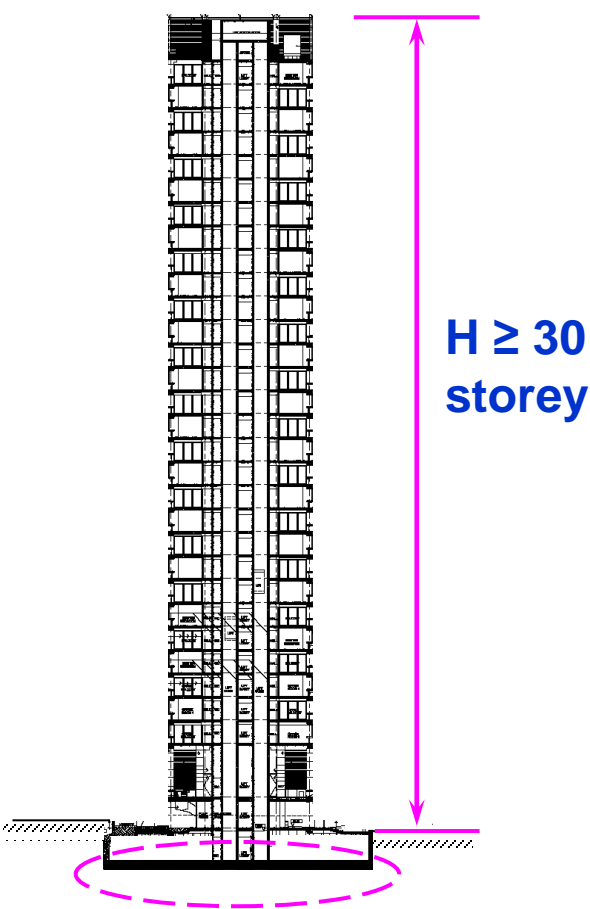

**GBW = Raft foundation**

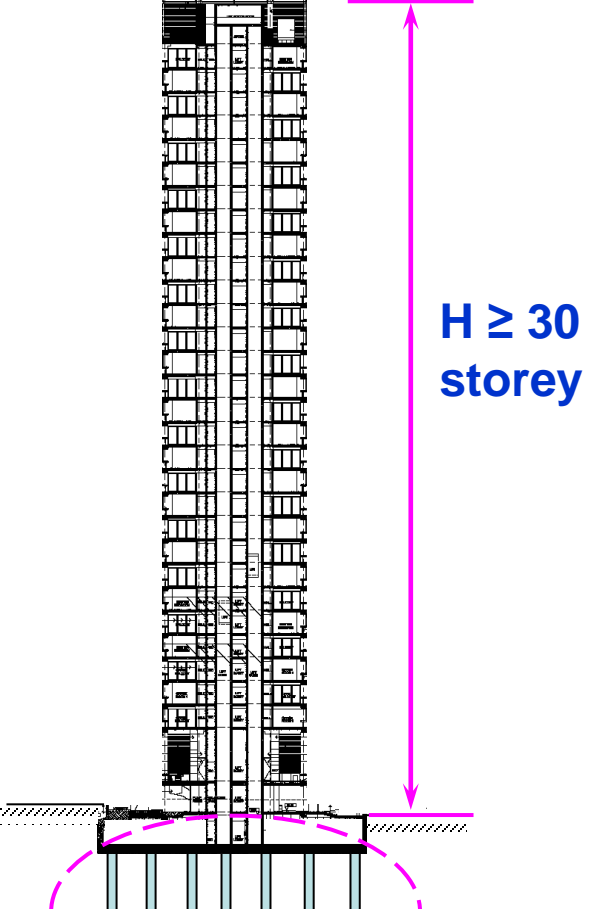

**GBW = Caisson, barrette piled foundation or Piled raft foundation**



# Examples of Non Geotechnical Building Works



# Building Works: Small area shaft and trenches

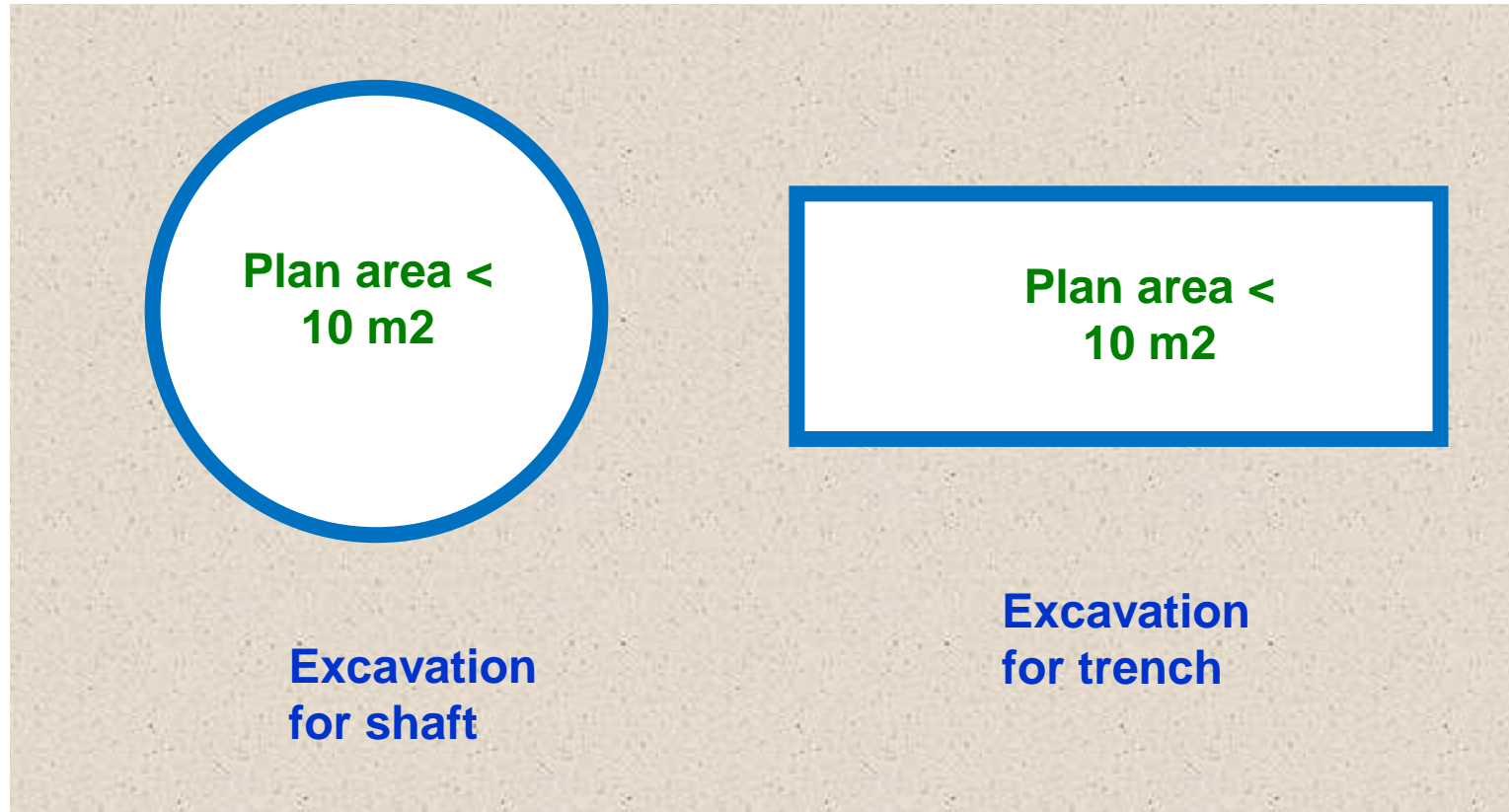

Any excavation for shaft and trenches with plan area of the excavation not exceeding 10 square metres (e.g. trench excavation for diaphragm wall, excavation for bored piles) is exempted from the requirements of geotechnical building works (GBW). For example, an excavation for a small shaft with plan area less than 10 sq m is exempted from the requirement of GBW but still subjected to ERSS submission requirements.



# Insignificant Building Works: Utilities such as Sewers, water and gas pipes with diameter of 1m or less

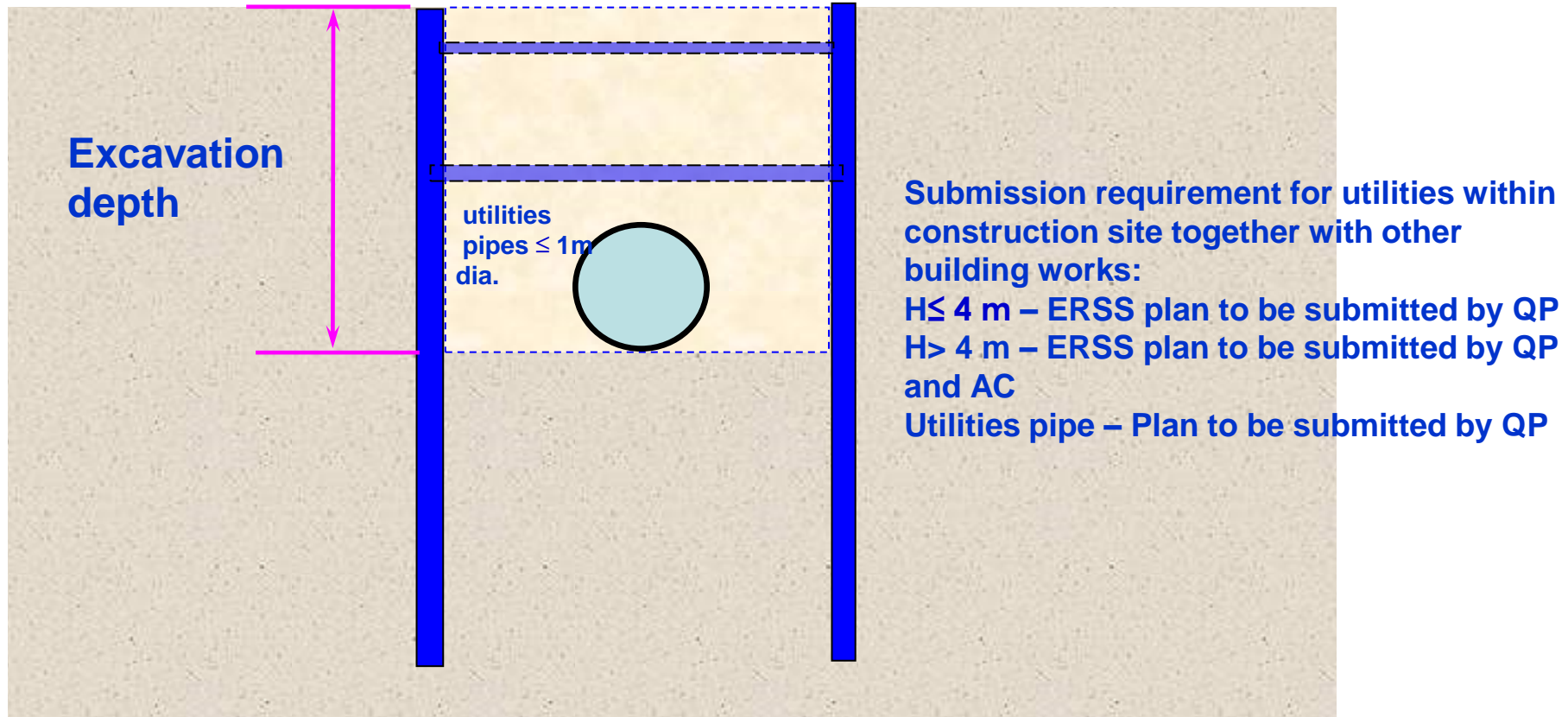

Any trench for the purpose of laying sewer/utility (including its associated shaft or manhole) not exceeding 1m in internal diameter in conjunction with the sewer/utility system is classified as insignificant building work which requires no plan submission. This exemption does not apply to cases where the trench for the purpose of laying sewer/utility (internal diameter less than 1m) are within a construction site with other building works where the size of trench exceeds 10 square metres or exceeds 2m in depth.



# Excavation Works: Utility pipes (such as sewer, water and gas pipes) with diameter larger than 1 m and not greater than 2 m and its associated shaft or manhole

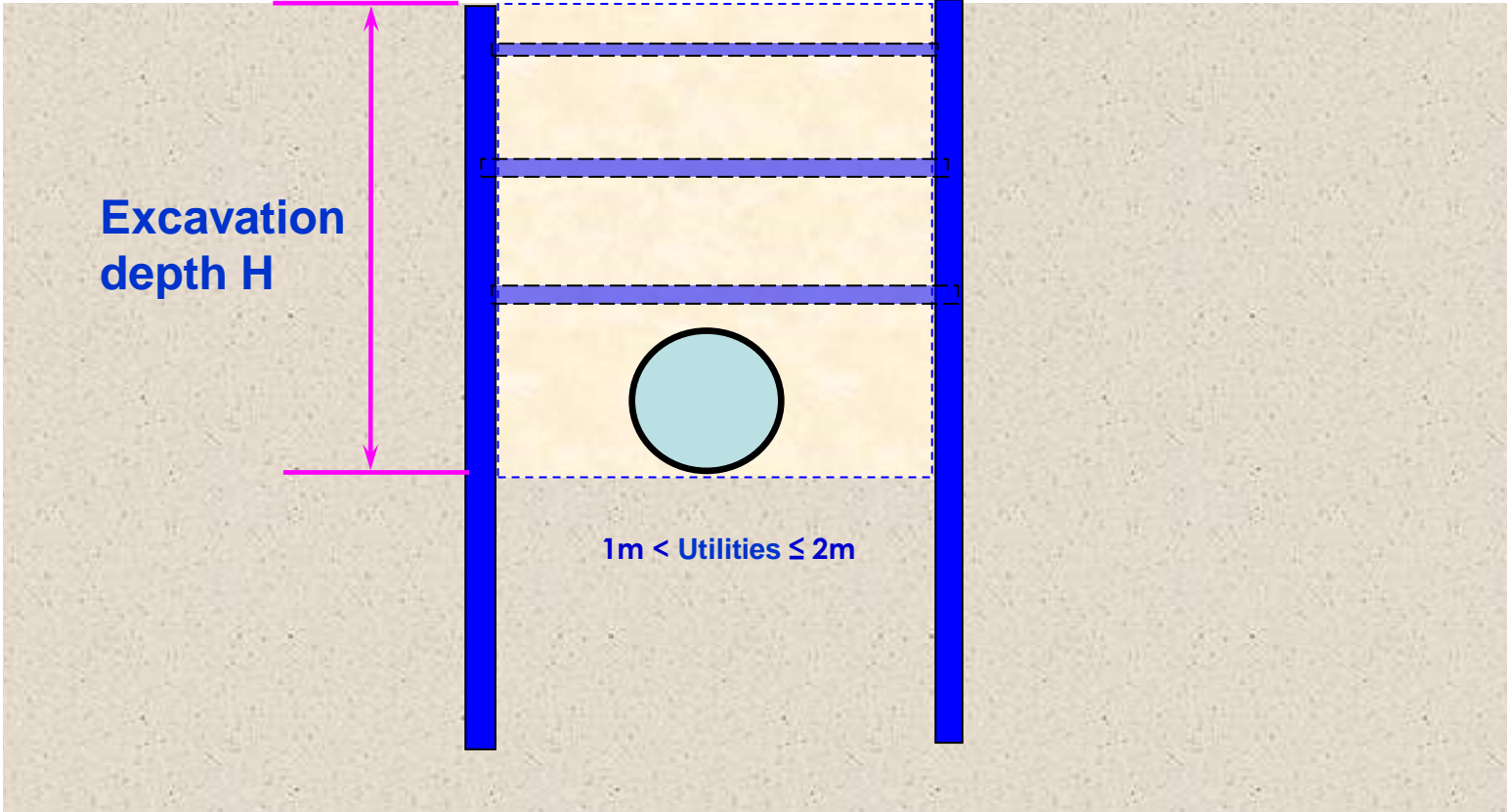

**Submission requirement:**  
 $H \leq 4$  m – ERSS plan to be submitted by QP  
 $H > 4$  m – ERSS plan to be submitted by QP and AC  
Utilities pipe – Plan to be submitted by QP and AC



**For enquiries:**

**Online Feedback Form: <https://www.bca.gov.sg/feedbackform/>**

