

Understanding the Approved Document

Issued by the Commissioner of Building Control
Under Regulation 27 of the Building Control Regulations

Based on Approved Document Version 7.06
June 2024

This handbook is electronically published by the Building and Construction Authority, Singapore.

The Building and Construction Authority (“BCA”), its agents, employees and subcontractors are not to be held liable for any claim or dispute arising out of or relating to the information provided in this handbook. BCA reserves the right to update this handbook periodically without prior notice.

The contents of this handbook are protected by copyright and other forms of proprietary rights. All rights, title and interest in the contents are owned by, licensed to or controlled by BCA and shall not be reproduced, republished, uploaded, posted, transmitted or otherwise distributed in any way, without the prior written permission of BCA. Modification of any of the contents or use of the contents for any other purpose will be a violation of BCA’s copyright and other intellectual property rights.

Copyright © 2024 Building and Construction Authority

INTRODUCTION

Aim:

The aim of this handbook is to assist the reader in understanding the architectural requirements from Clause C to P of the Approved Document Ver 7.05. This handbook is expected to be useful to architects and designers who may need guidance about compliance with the building regulations.

FEATURES

This book contains a number of features to aid understanding of the Approved Document:

Explanatory Notes

Clauses in Approved Document consist of technical jargons which can be better understood using diagrams. Definitions of technical terms as well as diagrams and photographs are used to explain the clauses to aid understanding.

Site Observations

The information provided here pre-empts the industry on the possible and frequently seen non-compliances found on site.

Additional Clarifications

Additional Clarifications provide further explanations on the Clauses stated in Approved Document as well as common queries raised by practitioners.

Explanatory Notes, Site Observation and Additional Clarifications are correlated with the clauses in the Approved Document, for ease of reference and understanding.

These features are inserted after and below a particular clause which requires explanation. An example is shown below where **A** is the Clause, and where **B** is a site observation.

Example:

A E.3.6.2 The height of the handrail shall be between 800 mm and 1000 mm above the pitch line.

B *Site Observations E.3.6.2 – Measurement for Height of handrail*

The height of handrail shall be measured from the pitch line as shown below.



Figure E—XII: An example on the measurement of height of handrail from pitch line

CONTENTS

		Page
C	Headroom and Ceiling Height	
C.1	Objective	1
C.2	Performance requirement	1
C.3	Acceptable solution	4
C.3.2	Headroom	4
C.3.3	Ceiling height	13
D	Accessibility in Built Environment	
D.1	Objective	14
D.2	Performance requirement	14
D.3	Acceptable solution	14
E	Staircases	
E.1	Objective	15
E.2	Performance requirement	15
E.3	Acceptable solution	16
E.3.2	Projection	16
E.3.3	Width of staircase	16
E.3.4	Risers and treads	17
E.3.5	Landing	21
E.3.6	Handrails	25
E.3.7	Stair Nosing	32
F	Lighting	
F.1	Objective	35
F.2	Performance requirement	35
F.3	Acceptable solution	35
F.3.2	Natural lighting	35
G	Ventilation	
G.1	Objective	36
G.2	Performance requirement	36
G.3	Acceptable solution	37
G.3.2	Natural ventilation	40
H	Safety from Falling	
H.1	Objective	47
H.2	Performance requirement	47
H.3	Acceptable solution	52
H.3.2	Height of barrier	52
H.3.3	Horizontal loading and design of glass panel barriers	57
H.3.4	Size of opening	57
H.3.4A	Requirements to prevent climbing	60
H.3.5	Glass barrier	67

I	Energy Efficiency	
I.1	Objective	68
I.2	Performance requirement	68
I.3	Acceptable solution	68
I.3.2	Air-conditioned building	69
I.3.3	Non air-conditioned building	70
I.3.4	Air tightness and leakage	70
I.3.5	Air-conditioning system	71
I.3.6	Artificial lighting	71
I.3.7	Switching control	71
I.3.8	Energy auditing	71
J	Roof	
J.1	Objective	72
J.2	Performance requirement	72
J.3	Acceptable solution	72
K	Lifts and Escalators	
K.1	Objective	73
K.2	Performance requirement	73
K.3	Acceptable solution	74
L	Lightning Protection	
L.1	Objective	79
L.2	Performance requirement	79
L.3	Acceptable solution	79
M	Safety of Windows	
M.1	Objective	83
M.2	Performance requirement	83
M.3	Acceptable solution	83
N	Use of Glass at Height	
N.1	Objective	86
N.2	Performance requirement	86
N.3	Acceptable solution	86
O	Protection from injury by Vehicles in Buildings	
O.1	Objective	89
O.2	Performance requirement	89
O.3	Acceptable solution	89
O.3.2	Horizontal loading of barrier	89
P	Daylight Reflectance	
P.1	Objective	90
P.2	Performance requirement	90
P.3	Acceptable solution	90

Annex 1	Loft Requirements	93
Annex 2	Mechanised Car Parking Systems	97
Annex 3	Movable Panels	100

LIST OF FIGURES

C HEADROOM AND CEILING HEIGHT

C.1 OBJECTIVE

C.1.1 The objectives of paragraphs C.2.1 are –

- (a) to protect people from injury caused by inadequate headroom; and
- (b) to prevent loss of amenity caused by inadequate height of room or space.

C.2 PERFORMANCE REQUIREMENT

C.2.1 Any room or space in a building must be provided with –

- (a) adequate headroom; and
- (b) adequate height,

for the intended uses of the room or space.

C.2.2 The requirements in paragraph C.2.1(a) and (b) do not apply to any of the following rooms or spaces:

- (a) any attic that –
 - (ii) does not exceed an area of 10 square metres; and
 - (iii) is in a house that is built for the owner's own use;
- (b) any equipment or plant room;
- (c) the underside of any staircase or escalator if the staircase or escalator is not located along an access route or circulation space;
- (d) any toilet or bathroom in any house built for the owner's own use;
- (e) any store room not exceeding an area of 6 square metres.

Site Observations C.2.2 (c) – Headroom under staircases and escalators

a) Some examples of measures taken to mitigate headroom hazards at the underside of staircase.



Figure C—I: Circulation spaces at the underside of staircases/ escalators

Note: In accordance with Clause 4.3.2.1 of the Code on Accessibility in the Built Environment 2019, barriers must include detectable guardrails between 400mm and 580mm above the floor level.

- b) In *Figure C-II*, the low headroom hazard near the entrance door is mitigated by enclosing the affected circulation area



Figure C—II: Low headroom at entrance is mitigated by building up a storage area underneath the staircase

- c) Headroom requirements are applicable where deficient of headroom affects the functional use of space and poses as an overhead hazard for users.



Figure C— III: Function of space at underside of staircase

C.2.3 The requirement in paragraph C.2.1(b) does not apply to any of the following rooms or spaces:

- (a) any corridor or lobby;
- (b) any toilet, bathroom or powder room;
- (c) any localised area within a room or space where there is a drop in ceiling height due to physical constraints such as structural beams or building services.

C.3 **ACCEPTABLE SOLUTION**

C.3.1 The requirement in paragraph C.2.1 is deemed to be satisfied if the specifications set out in paragraphs C.3.2 and C.3.3 are complied with.

C.3.2 **Headroom**

C.3.2.1 The headroom of every room, access route and circulation space shall not be less than 2.0 metres.

Site Observations C.3.2.1 – Headroom of room, access route and circulation space

Common scenarios of non-compliance with headroom requirement:

BEFORE

AFTER RECTIFICATION

The sign was shifted to prevent accidental head injury.

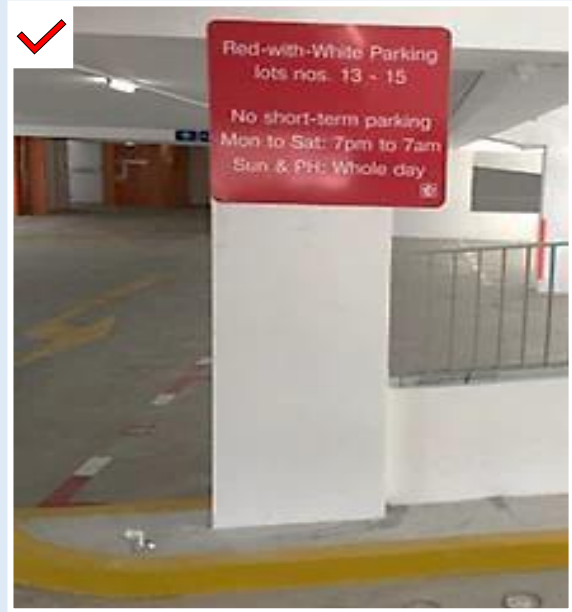
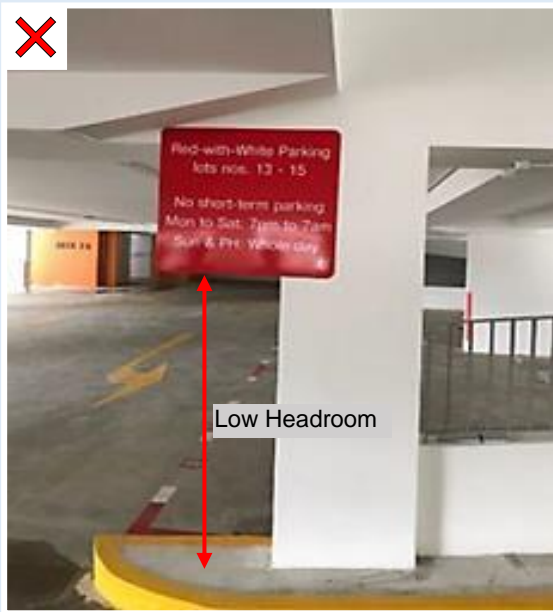

Figure C—IV: Change of location of signage to meet headroom requirements

The profile of steps were rectified to meet the requirement for 2.0m clear headroom.

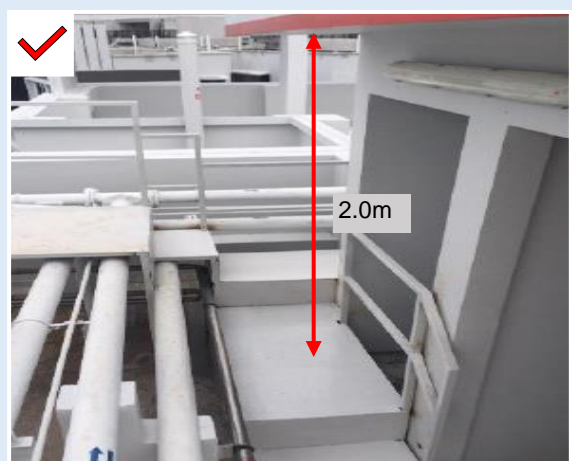
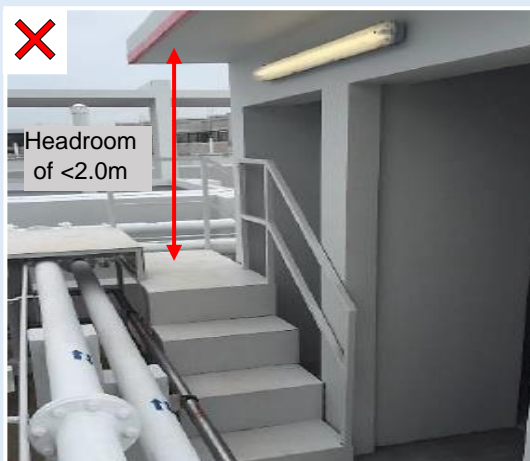

Figure C—V: Steel staircase was rectified to increase headroom space

Non-compliances with headroom requirement are often observed in slanted structures. Headroom hazards are mitigated by the addition of guards or barriers to prevent a person from walking near the slanted structure where headroom is less than 2m.

BEFORE



AFTER RECTIFICATION

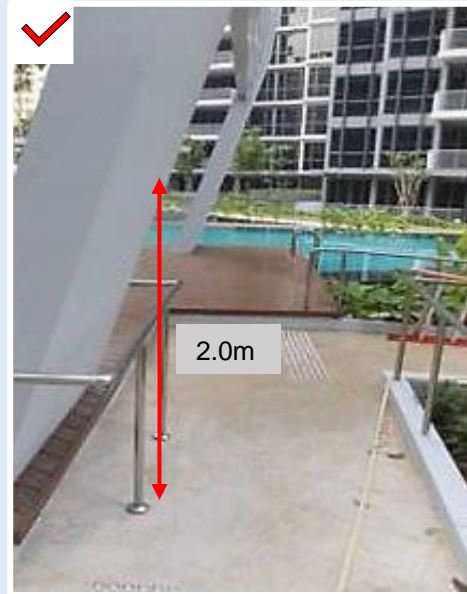

Figure C—VI: Slanted structure along passageway were rectified with placement of guards/ barriers



Figure C—VII: Slanted structure at gym area was straightened

C.3.2.2 For sheltered car parks, the headroom at parking lots and driveway shall not be less than 2.2 metres.

- Note:
- 1 The term “access route” shall include a covered walkway or footway of a building.
 - 2 The headroom is measured from the finished floor level to –
 - a) in the case of a doorway, the underside of the transom;
 - b) in the case where a window opens into an access route or circulation space, the underside of the opened window, or
 - c) in all other cases, the underside of any beam, duct, service pipe, fixture, fitting or other obstruction or projection.
 - 3 The headroom along a flight of staircase is measured vertically between the pitch line and any point directly above that limits the headroom. See Figure C.3.2.1(a) for illustration of headroom measurement at staircases.
 - 4 The pitch line is the notional line joining the leading edge or nosings (if any) of successive stair treads within a flight of a stairway.

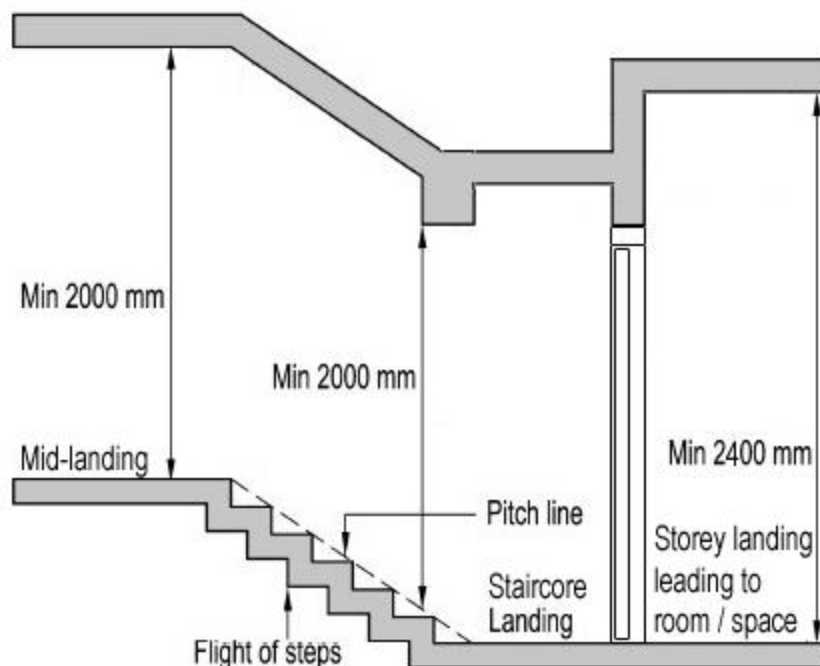

Figure C.3.2.1(a) – Measurement of Headroom

Site Observations C.3.2.2 – Headroom at parking lots and driveway

The minimum headroom clearance from the finished floor level to the underside of any projections along driveway including beams, direction signs, sprinkler heads, electrical fittings, etc. is **2.2m**.

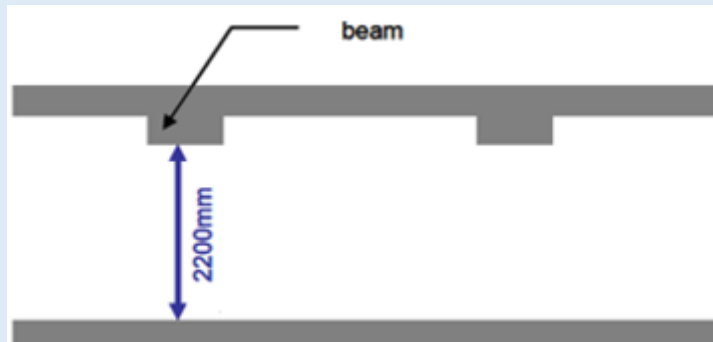

Figure C—VIII: Measurement of headroom along driveway



Figure C—IX: Comparison of headroom measurements on the driveway and circulation path



Figure C—X: Headroom non-compliances at the parking lot

Site Observations C.3.2.2 – Casement windows opening into public circulation space



Figure C—XI: Headroom shortfall along public circulation space rectified with placement of guards/barriers

Site Observations C.3.2.2 – Headroom of room, access route and circulation space for public circulation space



Figure C—XII: Openable windows found in public access space that reduced the required width of accessible route

Non-compliances in headroom requirement are often observed to be due to openable windows swinging into circulation routes and communal spaces. These are some of the acceptable measures for openable windows swinging into public circulation space.

- (i) Allowance of protrusion, not exceeding 100mm. This protrusion not exceeding 100mm shall also be considered to reduce the width of the accessible route.
- (ii) Protrusion exceeding 100mm is acceptable, with provision of barrier or planter strip, as long as the protrusion is within the width of barrier and planter strip, to prevent walking into it.
- (iii) Casement window swinging into M&E spaces that are not easily accessible to public.



Figure C—XIII: Barriers and planting strips are some of the acceptable measures for public circulation space

Site Observations C.3.2.2 – Headroom of casement windows opening to private spaces in residential developments



Figure C—XIV: Windows found in private domain spaces

Headroom issues due to openable window **do not apply** to private domain spaces. E.g. Penthouse, duplexes, cluster housing, landed houses built for own use and developer built.

Site Observations C.3.2.2 – Headroom along staircase



Figure C—XV: Headroom at staircase mid-landing with projection of light fixture

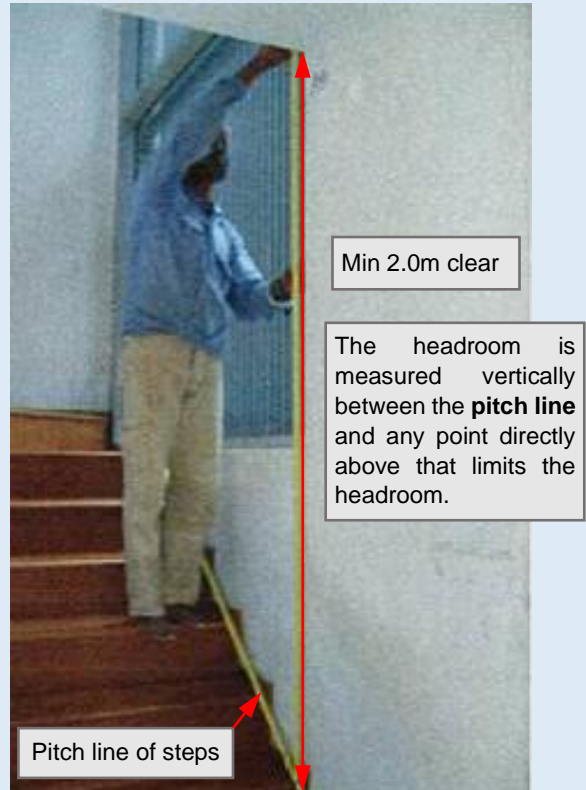

Figure C—XVI: Headroom measurement from pitch line of staircase nosing



Figure C—XVII: Examples of headroom non-compliances along staircases

C.3.3 Ceiling height

C.3.3.1 The ceiling height of rooms and spaces shall not be less than 2.4 metres.

Note: The ceiling height is measured from the finished floor level to the underside of any slab, false ceiling or suspended ceiling, whichever is lower.

Explanatory Notes C.3.2, C.3.3 – Definition of Headroom and Ceiling Height

Ceiling Height - The distance between a room's finished ceiling and floor levels.

Headroom - The clear vertical distance measured from finished floor surface to an overhead obstruction.

Circulation space – The defined area in a building that an occupant uses to move from one space to another, such as a hallway, stair way, of an area in a room that leads to another room.

Pitch line – The notional line connecting the nosings of all treads in a flight of stairs.

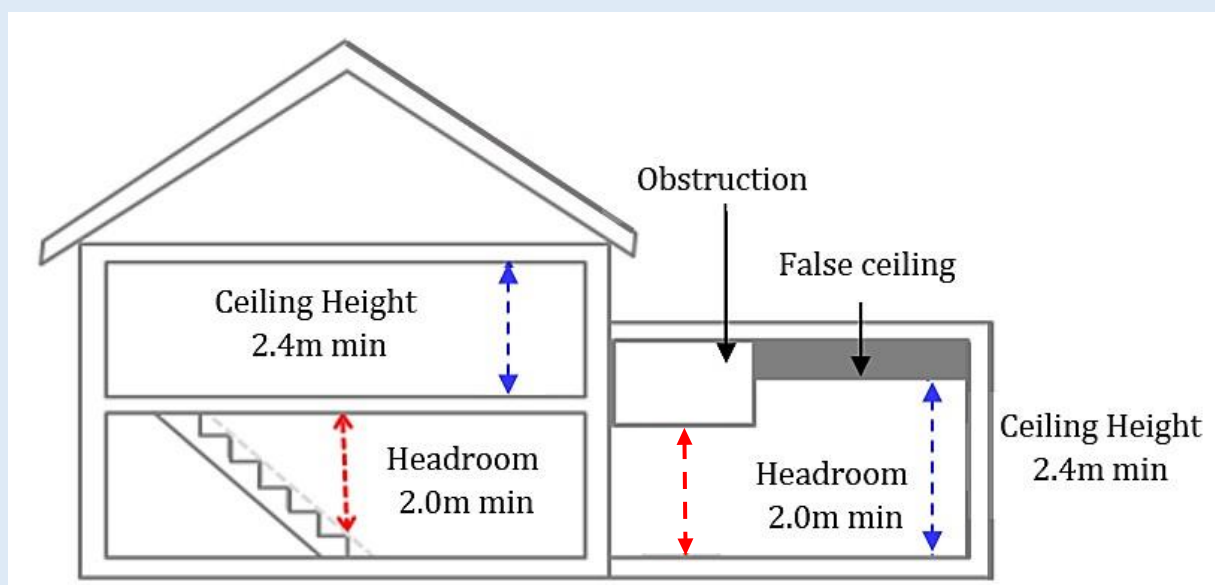

Figure C—XVIII: Diagram depicting the difference between 'Ceiling Height' and 'Headroom' (Section view)

As shown in above Figure C—XVIII, the headroom is measured from the finished floor level to the underside of any beam, duct, service pipe, fixture, fitting or other obstruction or projection.

Note: For more information on headroom and ceiling height requirements for loft, please refer to Annex 1.

D ACCESSIBILITY IN BUILT ENVIRONMENT

D.1 OBJECTIVE

D.1.1 The objective of paragraphs D.2.1 to D.2.4 is to ensure that persons with disabilities are able to easily gain access to and exit from the whole or part of a building, and that persons with disabilities, children between 90cm and 120cm in height, caregivers of infants, and nursing women are able to carry out their activities within the building with reasonable ease.

D.2 PERFORMANCE REQUIREMENT

D.2.1 At least one access route shall have barrier-free features to enable persons with disabilities to –

- (a) approach the building or the vehicle park; and
- (b) have access to those spaces where they may be expected to work or visit.

D.2.2 Sanitary facilities that are appropriate for use by persons with disabilities and sanitary facilities that are appropriate for use by children between 90cm and 120cm in height shall be adequately provided for use by such persons.

D.2.3 Appropriate facilities for lactation and changing of diapers shall be adequately provided and be accessible for use by nursing women and caregivers of infants.

D.2.4 Appropriate wayfinding guides such as signages or audible or tactile information providing directions or instructions shall be adequately provided within a building to guide persons with disabilities to spaces or facilities where or which they may be expected to work, visit or use.

D.3 ACCEPTABLE SOLUTION

D.3.1 The requirements in paragraphs D.2.1 to D.2.4 are deemed to be satisfied if the provisions and facilities for persons with disabilities, children between 90cm and 120cm in height, caregivers of infants, and nursing women comply with the Code on Accessibility in the Built Environment issued by the Commissioner of Building Control.

E STAIRCASES**E.1 OBJECTIVE**

E.1.1 The objective of paragraphs E.2.1 and E.2.2 is to protect people from injury and to facilitate access during movement from one level to another in a building.

E.2 PERFORMANCE REQUIREMENT

E.2.1 A staircase (including a flight of 2 steps or more) shall provide a safe and suitable passage for movement of people.

E.2.2 A staircase must have –

- (a) handrails or guides to assist movement (in accordance with paragraph E.3.6.1);
- (b) landings to break a fall and provide a place for rest;
- (c) sufficient width, tread and riser to avoid injury;
- (d) sufficient headroom to avoid injury; and
- (e) barriers to prevent people from falling off the edge of any open side that has a drop of 1,000 mm or more.

E.2.3 The requirement in paragraph E.2.2(a) does not apply to a staircase located in any of the following rooms or spaces:

- (a) any equipment or plant room;
- (b) any production area of an industrial building; and
- (c) any house built for the owner's own use.

E.2.4 The requirements in paragraph E.2.2(b) and (c) do not apply to a staircase located in any of the following rooms or spaces:

- (a) any equipment or plant room;
- (b) any production area of an industrial building;
- (c) any attic that –
 - (ii) does not exceed an area of 10 square metres; and
 - (iii) is in a residential building;
- (d) any house built for the owner's own use.

E.3 ACCEPTABLE SOLUTION

E.3.1 The requirements in paragraphs E.2.1 and E.2.2 are deemed to be satisfied if a staircase is designed and constructed in accordance with the specifications set out in paragraphs E.3.2 to E.3.7.

E.3.2 Projection

E.3.2.1 No projection, other than handrails, is allowed into the space of a staircase that is within a height of 2.0 m from the landing or pitch line.

Note:

The pitch line is the notional line joining the leading edge or nosings (if any) of successive stair treads within a flight of a stairway.

E.3.3 Width of staircase

E.3.3.1 The clear width of every staircase shall not be less than 1000 mm.

Note: *If the projection of the handrail into the clear width does not exceed 80 mm on each side of the staircase, the width is measured from:*

- (a) *The finished surfaces of the walls, if the staircase is enclosed on both sides by walls only; or*
- (b) *The finished surface of the wall and the inner side of the balustrade, if the staircase has a wall on one side and a balustrade on the other side; or*
- (c) *The inner sides of the balustrades if the staircase has balustrades on both sides.*

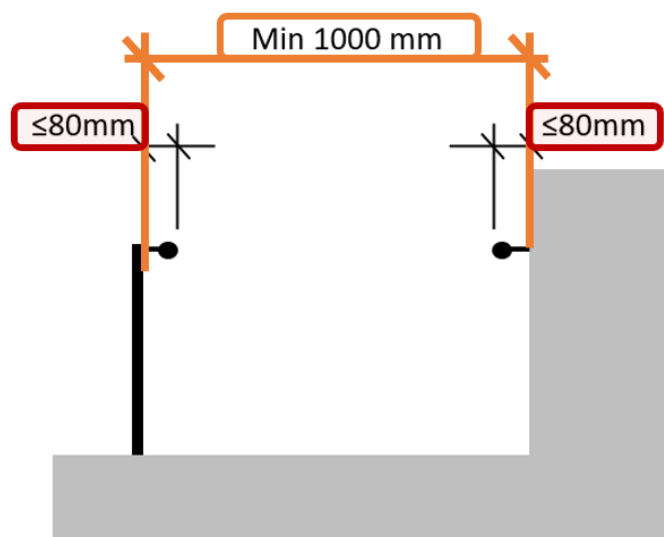

**Figure E.3.3.1(a) –
Measurement of Clear Width with 80mm or less handrail projection**

If the projection of the handrail into the clear width exceeds 80 mm on one or more side of the staircase, the clear width of the staircase shall be measured from:

- (a) The finished surface of the wall and the inner side of the handrail, if the staircase has a wall on one side and a handrail on the other side; or
- (b) The inner sides of the handrails if the staircase has handrails on both sides.

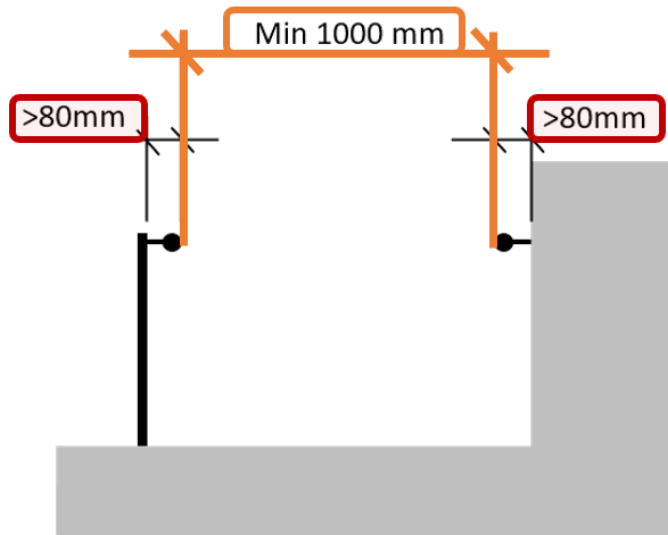

Figure E.3.3.1(b) – Measurement of Clear Width more than 80mm handrail projection

E.3.4 Risers and treads

E.3.4.1 The height of a riser shall not be more than 175 mm. (see Figure E.3.4.2(a) for measurement of “riser”)

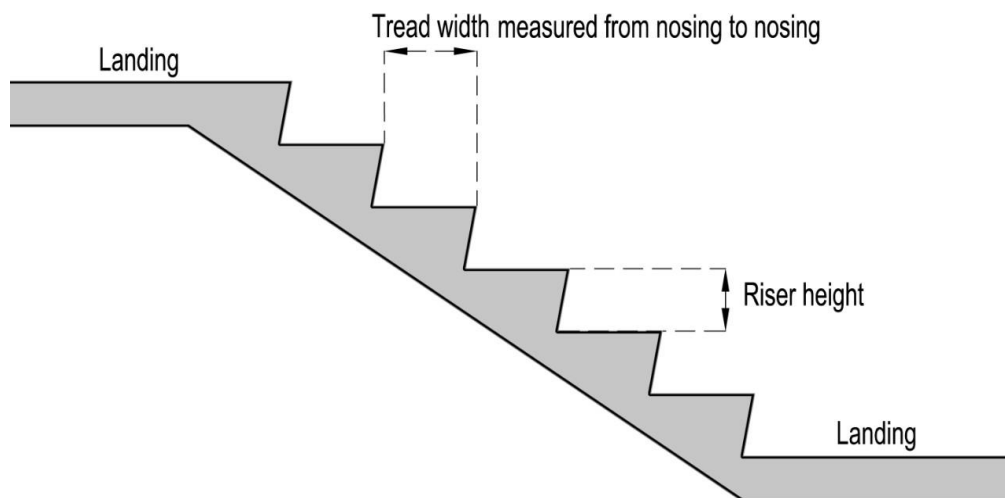

Figure E.3.4.2(a) – Measurement of Tread and Riser

- E.3.4.2 The width of a tread of a staircase (see Figure E.3.4.2(a) for measurement of “tread”) shall not be less than:
- a) 225 mm, if the staircase is in a residential unit within a residential building;
 - b) 250 mm, if the staircase is in an industrial building; or
 - c) 275 mm, if the staircase is in any other type of building, including common staircases in a residential building.

Explanatory Notes E.3.4.2 – Risers and treads

Tread width is measured from nosing to nosing:

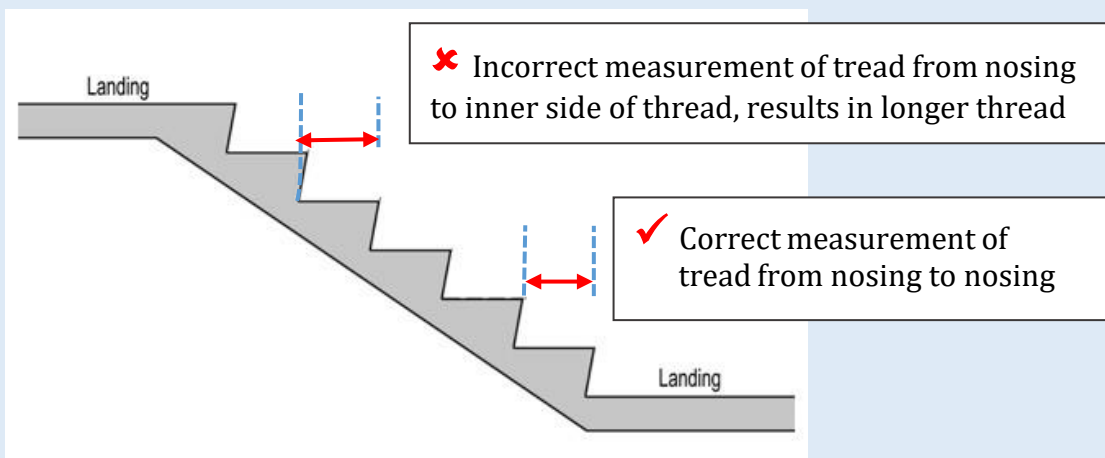

Figure E—I: Comparison of incorrect and correct measurement of tread size



Figure E—II: Measurement of tread with rounded nosing

E.3.4.3 The width of the tread of any tapered step shall be measured at a distance of 500 mm from the narrower end.

Explanatory Notes E.3.4.3 – Measurement of tread width for any tapered step

An example is a spiral staircase as shown in *Figure E—III* below:

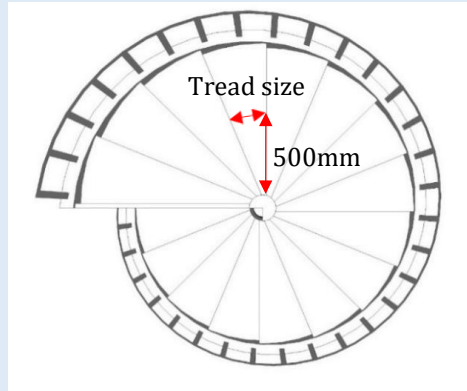

Figure E—III: Measurement of tread width for a spiral staircase

Since the width of tread is measured at a distance of 500mm from the narrower end, headroom clearance shall be measured at the distance of 500mm from the narrower end as well. The headroom measurement at this point shall not be less than 2m.

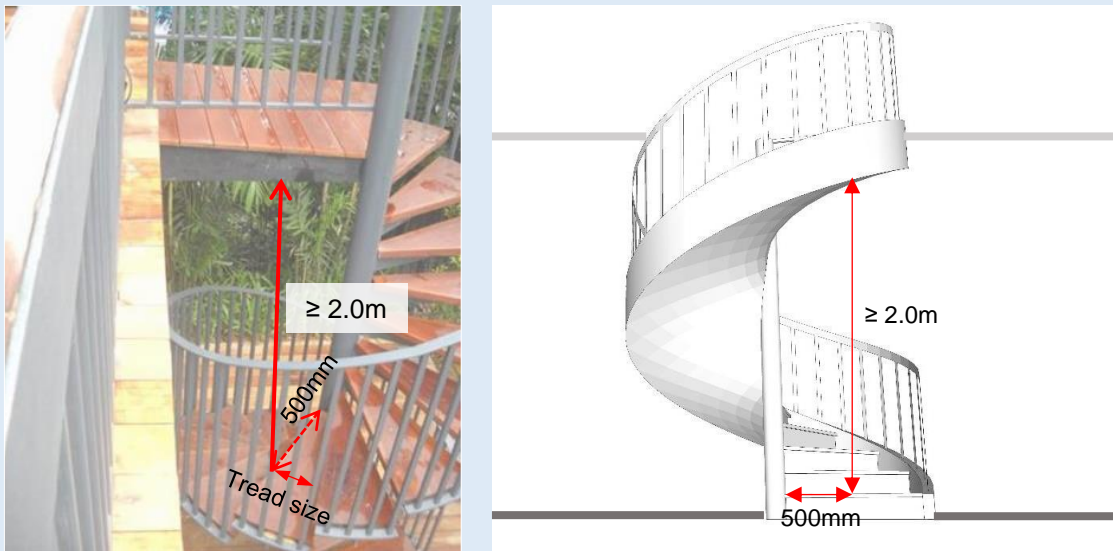

Figure E—IV: Measurement of headroom for a spiral staircase

E.3.4.4 The risers and treads within each flight of stairs shall be of uniform height and size.

- Note:
1. A tolerance of 5mm between two consecutive steps in any flight of staircase is acceptable.
 2. Uniformity of risers and treads is applicable to all rooms or spaces under paragraph E.2.4 (except houses built for owner's own use).

Site Observations E.3.4.4 – Uniform risers and treads within each flight of stairs

Irregular risers at staircases are often observed during site inspections.



Figure E—V: Examples of irregular risers

Incomplete finishing works on site will not allow the treads and risers to be measured accurately. In such cases, the staircase is deemed to be not compliant with the requirement.



Figure E—VI: Incomplete finishing work

E.3.5 Landing

E.3.5.1 A landing shall be provided at every floor level and door opening.

E.3.5.2 Except for spiral staircases, an intermediate landing shall be provided in between floor levels at intervals of not more than 18 risers.

E.3.5.3 The clear width of any landing shall not be less than 1000 mm. See Figure E.3.5.3(a) and (b) on how to measure landing width.

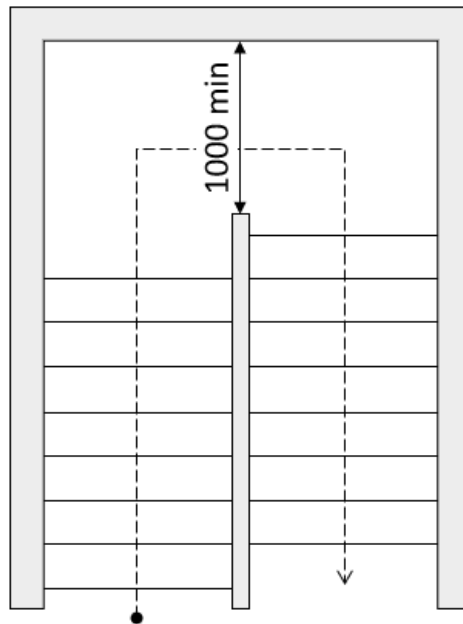

Figure E.3.5.3(a) Measurement of landing width

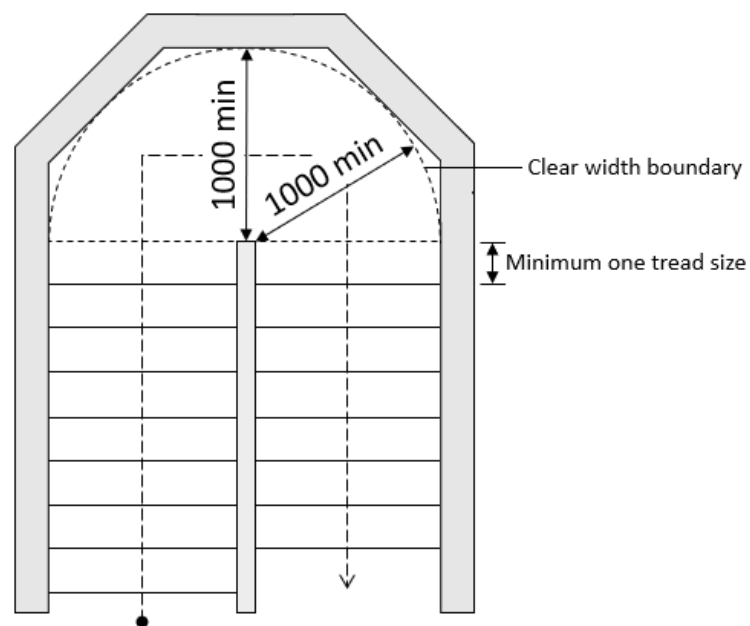

Figure E.3.5.3(b) Measurement of the width of an irregular landing

Explanatory Notes E.3.5.3 – Clear width of landing

An example of the measurement of the clear width at landing.



Figure E—VII: Measurement of the width of staircase with protruding kerb

In this example where there is a protruding kerb, the measurement is taken from the kerb to the opposite wall.

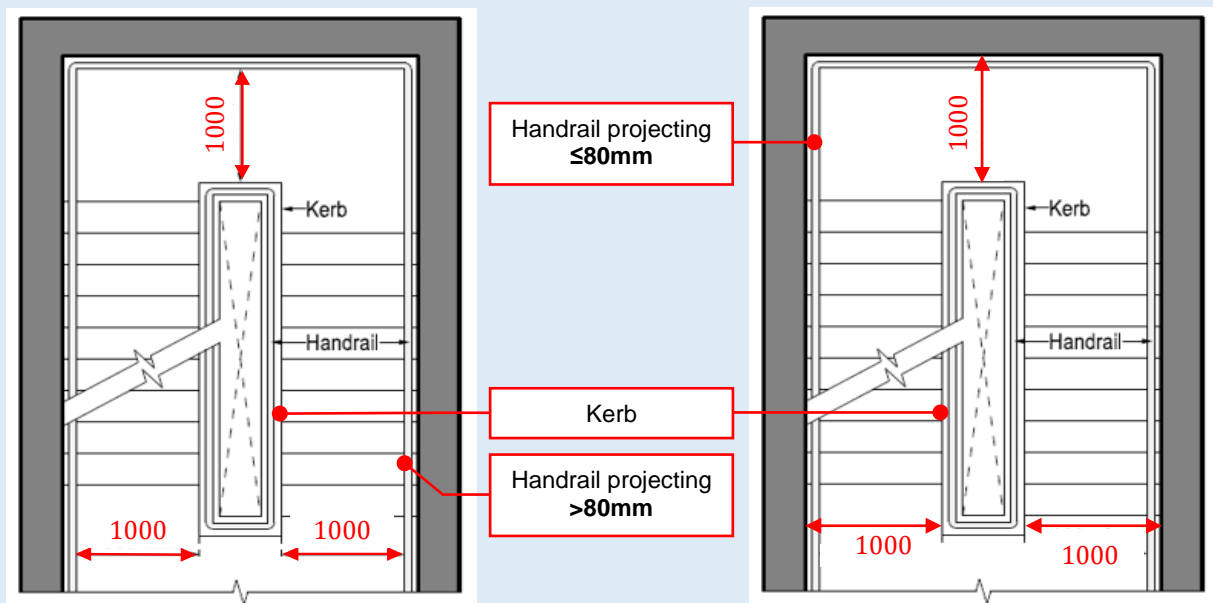

Figure E—VIII: Measurement of the width of staircase with protruding kerb and handrail projecting >80mm versus handrail projecting ≤80mm

The measurement is taken from the protruding kerb to the opposite handrail projecting >80mm. For handrails projecting ≤80mm, the measurement can be taken from the protruding kerb to the opposite wall.

If the landing is irregular (E.g. With rounded or chamfered corners), measurement of the width of the landing will be taken at one tread distance from the last step of that landing.

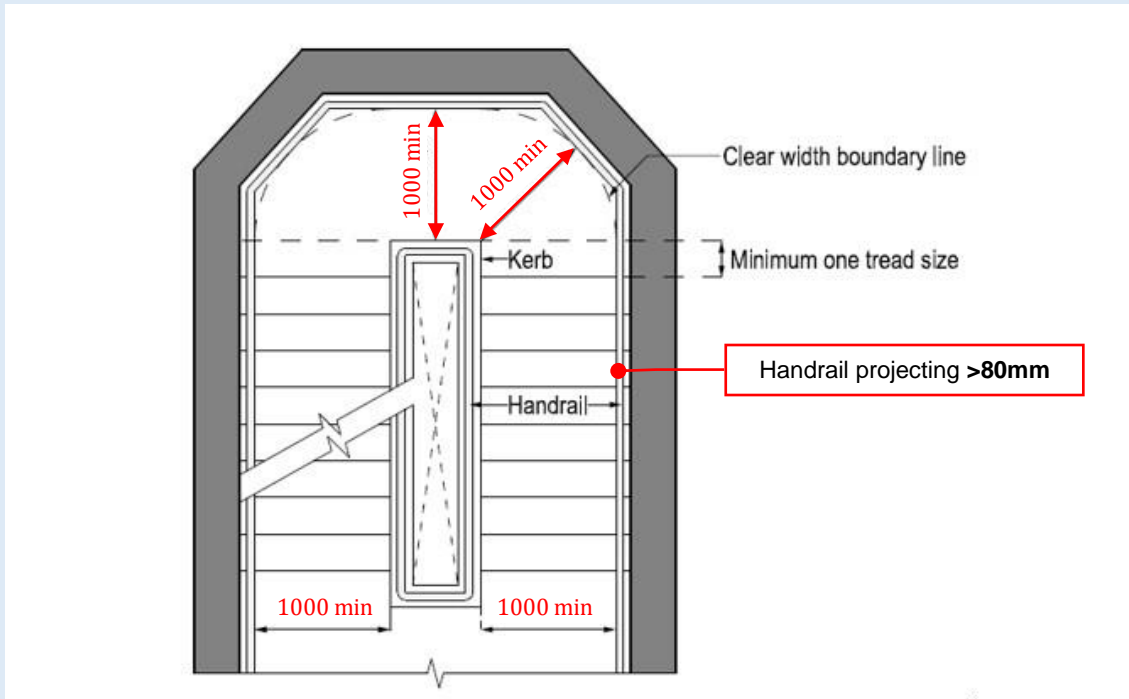

Figure E—IX: Measurement of width of staircase for irregular landings with handrail projecting >80mm

E.3.5.4 A landing shall not have any step or drop. A winder does not constitute a landing and is only allowed in a residential unit, where one winder is allowed in every 90 degrees turn in the staircase with a minimum of one tread in between. See Fig. E.3.5.4 on acceptable winder layout.

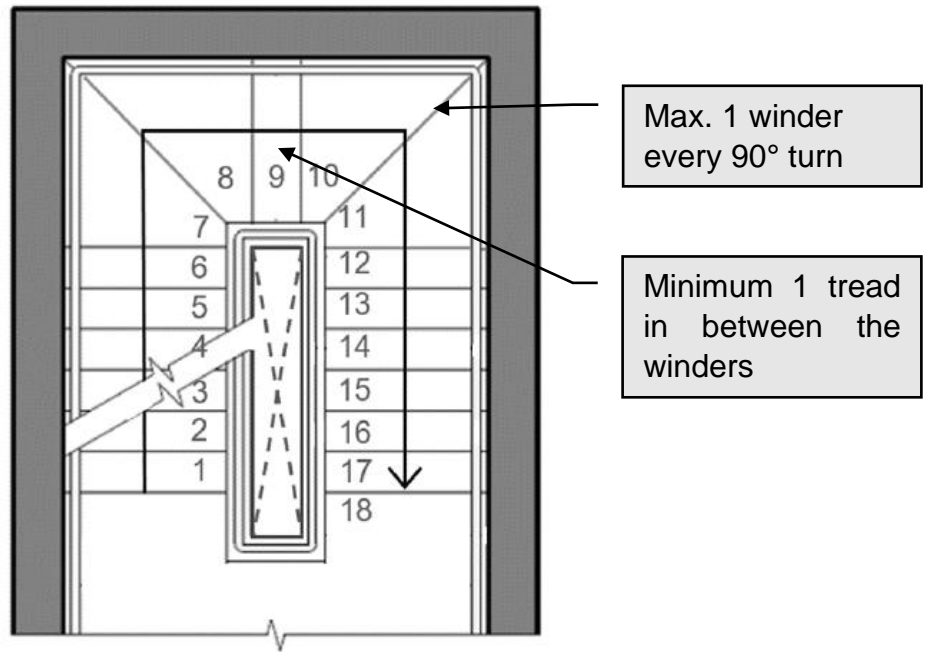

Figure E.3.5.4(a) – Winders as part of total riser count

Site Observations E.3.5.4 – Landing shall not have any step or drop

This landing was initially constructed with a drop. Rectifications were done to change the drop to 2 steps to comply with the requirement.



Figure E—X: An example of landing with a step being rectified

E.3.6 Handrails

E.3.6.1 A handrail shall be provided on at least one side of the flight of any staircase with more than 5 steps.

Site Observations E.3.6.1 – Handrail provision



Figure E—XI: Photos from site inspections that depict staircase which are not provided with handrail

E.3.6.2 The height of the handrail shall be between 800 mm and 1000 mm above the pitch line.

Explanatory Notes E.3.6.2 – Measurement for height of handrail

The height of handrail shall be measured from the pitch line as shown below.



Figure E—XII: An example on the measurement of height of handrail from pitch line

E.3.6.3

Handrails shall:

- a) have a circular section from 32 mm to 50 mm in diameter or an equivalent gripping surface as shown in Code on Accessibility in the Built Environment, Clause 4.7.3.1(b); and
- b) have a clear space between the handrail and all wall surfaces as shown in Figure E.3.6.3(a) of –
 - (ii) not less than 40 mm; or
 - (iii) not less than 60 mm where the wall has a rough surface.

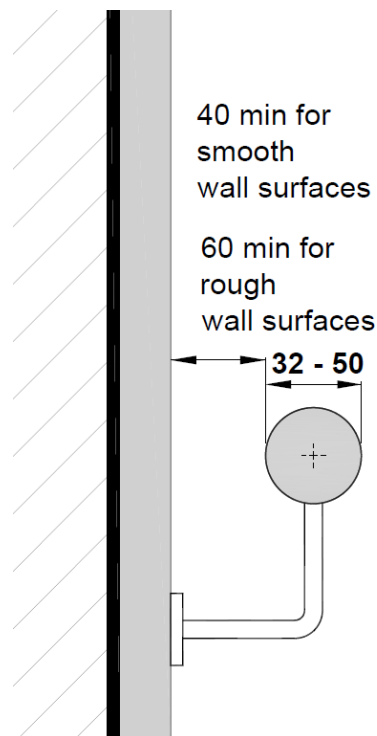

Figure E.3.6.3(a) – Handrails Clearance from Wall

Explanatory Notes E.3.6.3 – Requirements of handrail

The diagram below shows the acceptable circular sections of handrail profiles.

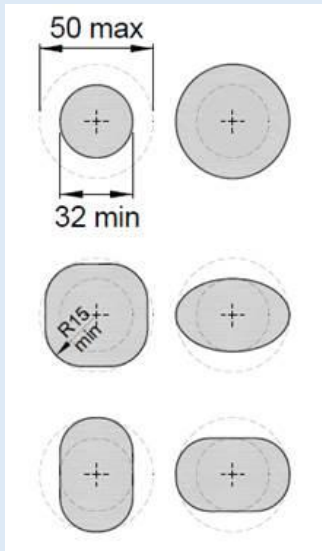

Figure E—XIII: Diagram of acceptable handrail profiles



Figure E—XIV: Unacceptable handrail profile with sharp corners

Site observations E.3.6.3 – Requirements of handrail



Figure E—XV:
(Photograph 1) Unacceptable handrail profile



Figure E—XVI:
(Photograph 2) Unacceptable handrail profile

Site Observations E.3.6.3 – Requirements of handrail on wall surfaces

The below examples show the clear space between smooth/rough wall surfaces and the handrail.

Smooth Wall Surface



Figure E—XVII: Clear space from smooth wall surface (Min. 40mm wall gap)

Rough Wall Surface



Figure E—XVIII: Clear space from rough wall surface (Min. 60mm wall gap)

- E.3.6.4 A recess containing a handrail shall extend at least 450mm above the top of the rail as shown in Figure E.3.6.4(a).

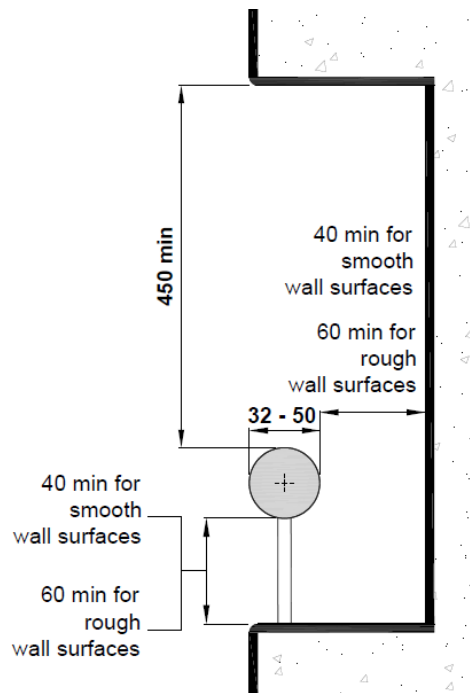

Figure E.3.6.4(a) – Handrail in Recess

- E.3.6.5 A handrail shall be continuous throughout the entire length of stairs and the ends of the handrail should be properly formed or rounded off so that they do not pose a danger to the user.

Site observations E.3.6.5 – Handrail shall be continuous



Figure E—XIX: Non-continuous handrail due to MEP fixture

The breaching inlet affected the continuity of the handrail. The breaching inlet was subsequently relocated.

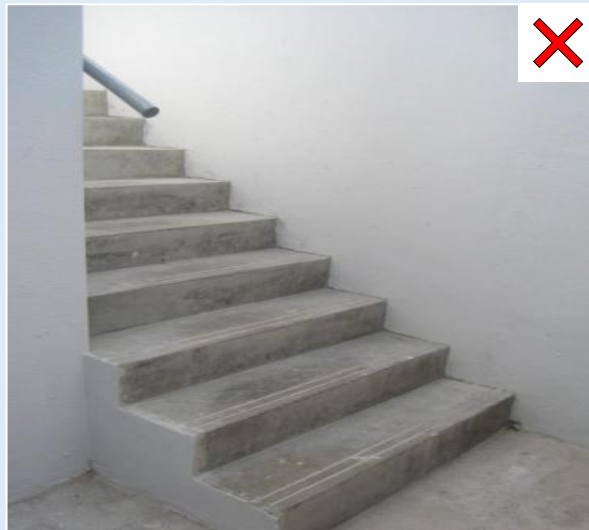

Figure E—XX: Non-continuous handrail

Note: For more information on the requirements of staircase and handrail for lofts, please refer to Annex 1.

Explanatory Notes E.3.6.5 – Handrail shall be properly formed or rounded off

Diagram showing some examples of handrails properly formed or rounded off.

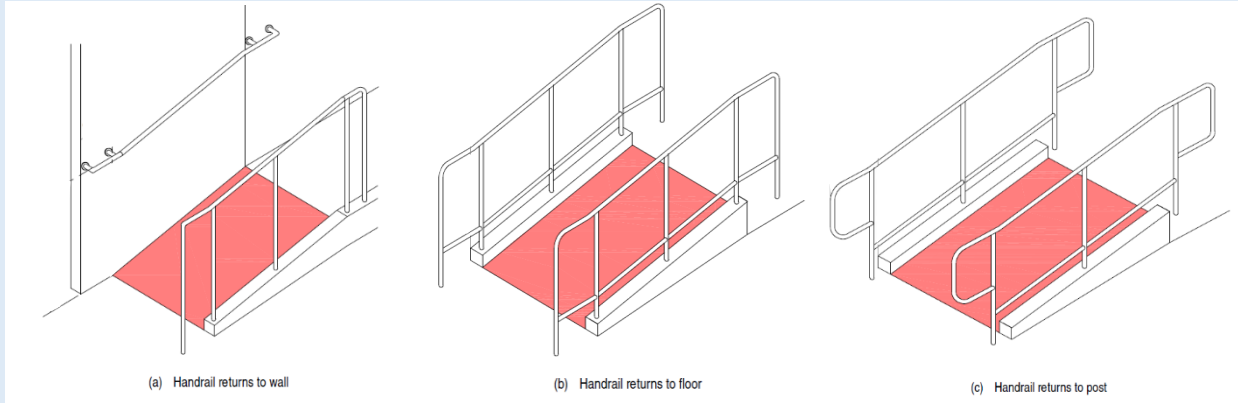

Figure E—XXI: Diagram showing examples of handrails properly formed or rounded off

Site Observations E.3.6.5 – Handrail shall be properly formed or rounded off



Figure E—XXII: Acceptable rounded off handrail that returns to the wall
(Only for residential units including landed houses)

E.3.7 Stair Nosing

E.3.7.1 Stair nosing must not project beyond the face of the riser and the riser may be vertical or have a splay backwards up to a maximum 25 mm, as shown in Fig E.3.7.1(a).

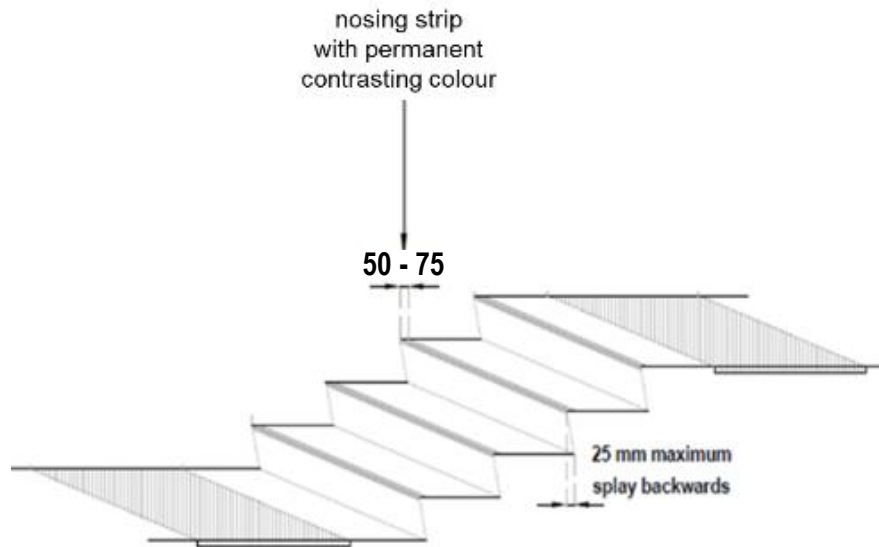

Figure E.3.7.1(a) – Stair nosing

- E.3.7.2 All steps must be fitted with nosing strips between 50 mm and 75 mm in width.
- E.3.7.3 Nosing strips must be of a colour that contrasts with the steps to make the drop edge of each step clearly visible.
- E.3.7.4 Painting of a nosing strip to achieve the colour contrast mentioned in subparagraph E.3.7.3 is not acceptable.

Note: The requirements on stair nosing in Section E.3.7 do not apply to residential units including landed houses. For the avoidance of doubt, the requirements in Section E.3.7 apply to common property such as corridors, lift lobbies etc. within residential developments.

Site Observations E.3.7.2 – Provision of nosing for maintenance areas



Figure E—XXIII: No nosing provision at maintenance areas

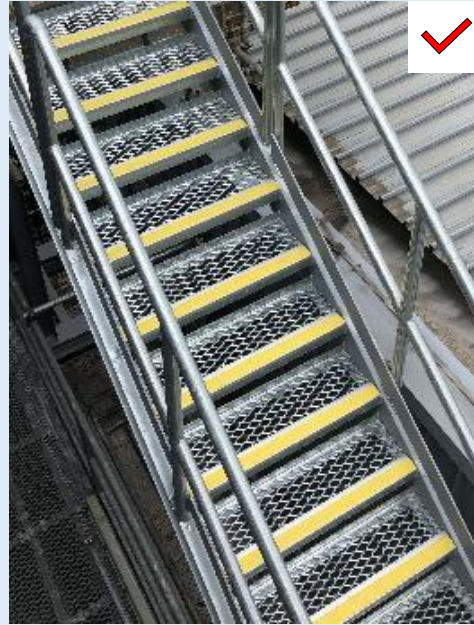

Figure E—XXIV: Nosing provision for perforated metal staircases at maintenance areas

Nosings are required for **all staircases** except for staircases within residential units.



Figure E—XXV: Nosing provision for perforated metal staircases at maintenance areas

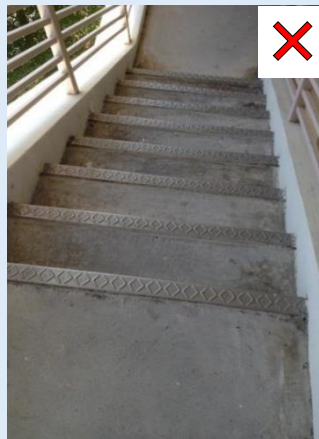
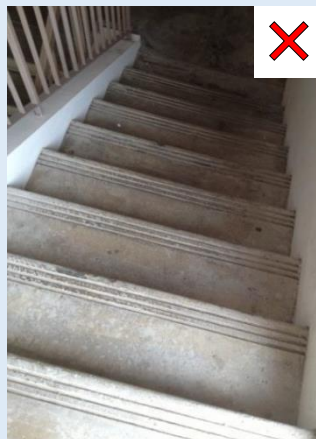

Figure E—XXVI: Nosings with poor colour contrast

Explanatory Notes E.3.7.4 – Painting of nosing strip is not acceptable

Acceptable nosing finishes

Fiberglass Reinforcement Plastic (FRP) / Glass Reinforcement Plastic (GRP)	Aluminum Frame with Silicon Carbide Anti-Slip Strip
	
	

Figure E—XXVII: Examples of acceptable nosing finishes



Figure E—XXVIII: Unacceptable nosing finishes - Adhesive nosing tapes

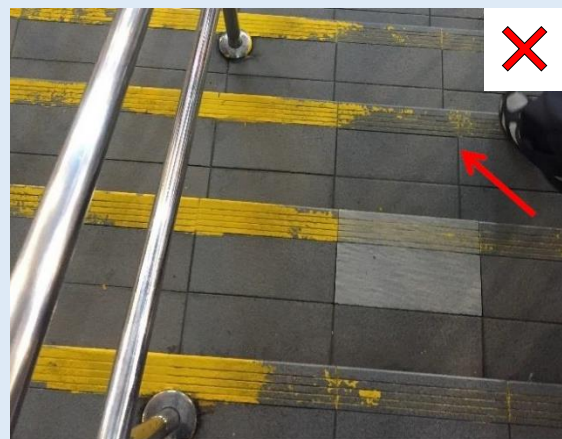

Figure E—XXIX: Unacceptable nosing finishes - Painted nosing wearing off over time

F LIGHTING**F.1 OBJECTIVE**

F.1.1 The objective of paragraphs F.2.1 and F.2.2 is to protect people from injury or loss of amenity due to lack of lighting, whether natural or artificial.

F.2 PERFORMANCE REQUIREMENT

F.2.1 Lighting shall be adequately provided in a building for its intended purpose.

F.2.2 Residential buildings, other than houses built by the owners for their own use, shall be provided with natural lighting for the purpose of paragraph F.2.1.

F.2.3 Despite paragraph F.2.2, artificial lighting may be provided to any of the following rooms or spaces in a residential unit, instead of natural lighting –

- (a) any toilet or bathroom;
- (b) any store room;
- (c) any basement;
- (d) any civil defence shelter.

F.3 ACCEPTABLE SOLUTION

F.3.1 The requirement in paragraph F.2.1 is deemed to be satisfied if –

- (a) natural lighting that complies with paragraph F.3.2.1; or
- (b) artificial lighting that complies with the recommended illuminance given in SS 531 - Code of Practice for Lighting of Work Places.

is provided.

F.3.2 Natural lighting

F.3.2.1 Natural lighting shall be provided by means of one or more windows or other openings with an aggregate light transmitting area of not less than 10% of the floor area of the room or space required to be lighted.

Note: The light transmitting area for a window and other similar devices may be measured over the framing members and glazing bars.

G VENTILATION

G.1 OBJECTIVE

G.1.1 The objective of paragraphs G.2.1 and G.2.2 is to protect people from loss of amenity due to lack of fresh air.

G.2 PERFORMANCE REQUIREMENT

G.2.1 Ventilation shall be adequately provided in a building for its intended occupancy.

G.2.2 Residential buildings, other than houses built by the owners for their own use, shall be provided with natural ventilation for the purpose of paragraph G.2.1.

G.2.3 The requirement in paragraph G.2.1 does not apply to any of the following rooms or spaces not exceeding an area of 6 square metres –

- (a) any store room;
- (b) any private lift lobby;
- (c) any walk-in wardrobe;

Explanatory Notes G.2.3 (c) – Ventilation for Walk-in Wardrobe

Examples of **acceptable** walk-in wardrobe:



Figure G—I: Walk-in wardrobe $\leq 6\text{sqm}$ without ventilation



Figure G—II: Walk-in wardrobe $> 6\text{sqm}$ with ventilation

G.2.4 Despite paragraph G.2.2, mechanical ventilation may be provided to any of the following rooms or spaces in any residential development:

- (i) any fitness room forming part of the communal area or common property;
- (ii) any clubhouse;
- (iii) any civil defence shelter;
- (iv) any toilet or bathroom;
- (v) any basement.

G.3 **ACCEPTABLE SOLUTION**

G.3.1 The requirement in paragraph G.2.1 is deemed to be satisfied if –

- (a) natural ventilation that complies with paragraphs G.3.2.1 and G.3.2.2; or
- (b) mechanical ventilation that complies with the ventilation rates given in SS 553 - Code of Practice for Air-Conditioning and Mechanical Ventilation in Buildings; or
- (c) air-conditioning system that complies with –
 - (for new erections of non-residential buildings)
 - (i) the ventilation rates given in SS 553 – Code of Practice for Air-Conditioning and Mechanical Ventilation in Buildings; and
 - (ii) the Minimum Efficiency Reporting Value (MERV) for cleaning the air given in SS 553 – Code of Practice for Air-Conditioning and Mechanical Ventilation in Buildings
 - (for all other types of building works)
 - the ventilation rates given in SS 553 – Code of Practice for Air-Conditioning and Mechanical Ventilation in Buildings, is provided.

Explanatory Notes G.3.1 (b) – Mechanical ventilation

Examples of **acceptable** mechanical ventilation systems/fittings:



Figure G—III: Window or wall mounted fan



Figure G—IV: Ducted fresh air supply outlets



Examples of **unacceptable** mechanical ventilation systems/fittings:

Air conditioning units, which only regulate temperature and do not cater for fresh air intake, will not comply with the ventilation rates given in SS 553. Therefore, such systems are not acceptable.



Figure G—V: An example of a standalone cassette unit that does not cater for fresh air intake

Site Observations G.3.1(b) – Provision of Mechanical ventilation for Cold Rooms

It is a requirement to provide fresh air vents for mechanical ventilation to cold rooms or chillers. (Not applicable to air-conditioned store room)

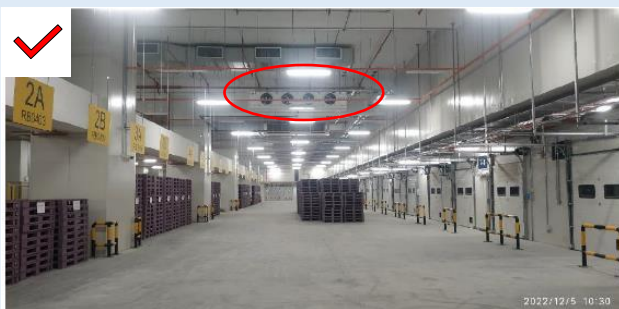

Figure G—VI: Production Room

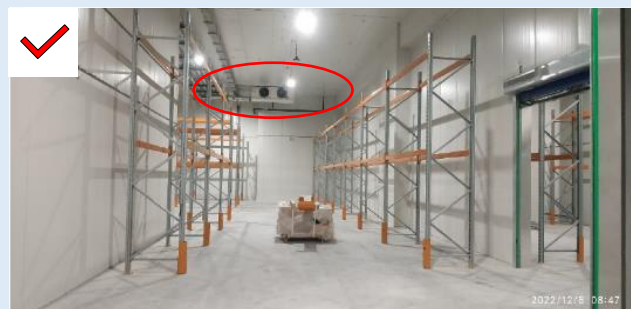

Figure G—VII: Frozen Chiller and Freezer Room

Additional Clarifications G.3.1 (b) – Mechanical ventilation

The natural ventilation requirement is applicable to **lift lobbies of mixed-use developments serving residents only**. Lift lobbies serving commercial tenants and residents can be mechanically ventilated or air-conditioned.

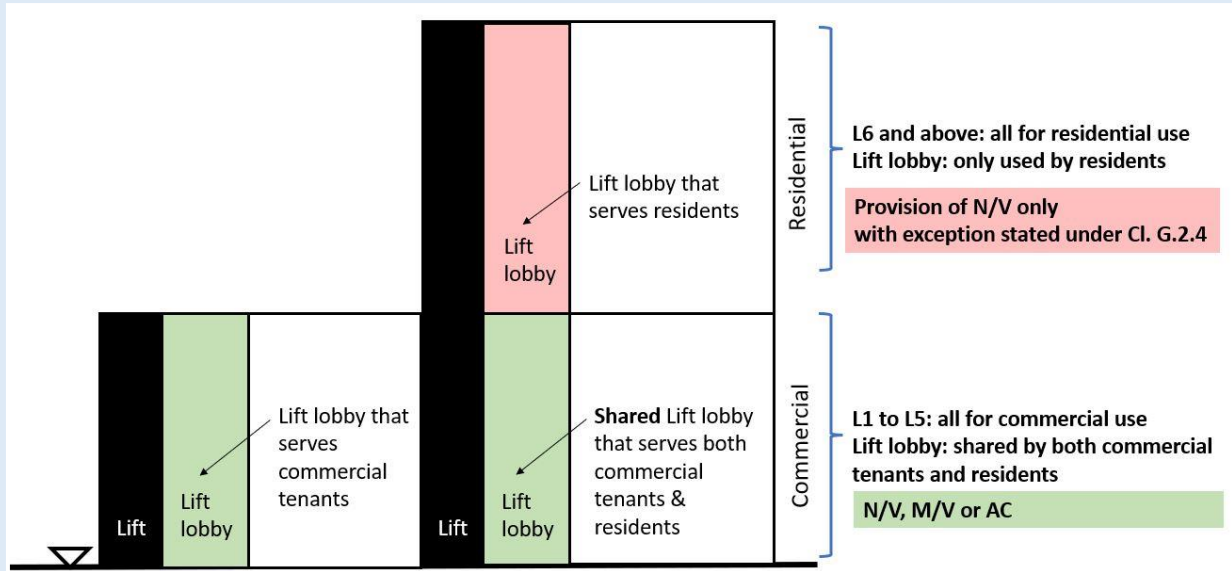

Figure G—VIII: Diagram on the provision of natural ventilation for lift lobbies of mixed developments

G.3.2 Natural ventilation

G.3.2.1 Natural ventilation shall be provided by means of one or more openable windows or other openings with an aggregate area of not less than –

- (a) 5% of the floor area of the room or space required to be ventilated; and
- (b) in the case of an aboveground car park, comply with relevant clause in SS553 – Code of Practice for Air-Conditioning and Mechanical Ventilation in Buildings.

Additional Clarifications G.3.2.1 (b) – Mechanical ventilation at car park

Should the car park or parts of the car park be mechanically ventilated, the ventilation rates of the mechanical ventilation system shall comply with **SS553**.

Note: Except otherwise stated in the following, any openable window or opening may be considered to be unobstructed and for the purposes of paragraph G.3.2.1, the effective open area may be taken as the entire area of the opening.

- (a) *The effective open area of a sliding window is the unobstructed area when the sliding window is opened fully.*
- (b) *The effective open area of any opening installed with fixed louvers shall be assumed to be 50% of the area of the opening.*
- (c) *For any casement windows installed with restrictors and can be opened at least 30 degrees or more, the effective open area of the window shall be assumed to be 50% of the window opening. Where the window is restricted from opening to an angle less than 30 degrees, the window shall be taken to have no effective open area for the purposes of paragraph G.3.2.1.*

Explanatory Notes G.3.2.1 – Natural ventilation

Examples of acceptable openings other than openable windows for the purpose of natural ventilation:



Figure G—IX: Openings in adjustable louvres



Figure G—X: Openings in fixed louvres



Figure G—XI: Openings in balcony



Figure G—XII: Openings of grille doors

Casement windows installed with restrictors:

<p>For casement windows that open less than 30 degrees, the effective open area of the window shall be assumed to be 0% of the window.</p>	<p>For casement windows that open 30 degrees or more, the effective open area of the window shall be assumed to be 50% of the window.</p>

Figure G—XIII: Casement windows with restrictors

Determining the floor area of a room or space:

The floor area of a room or space shall be ascertained by measuring the entire area within the inner finished surfaces of the full-height enclosing walls.

Where there are **no full-height walls** that separate different spaces into individual compartments, the floor area of the room shall be taken as the area of the entire space, as indicated in the blue area in the diagram below.

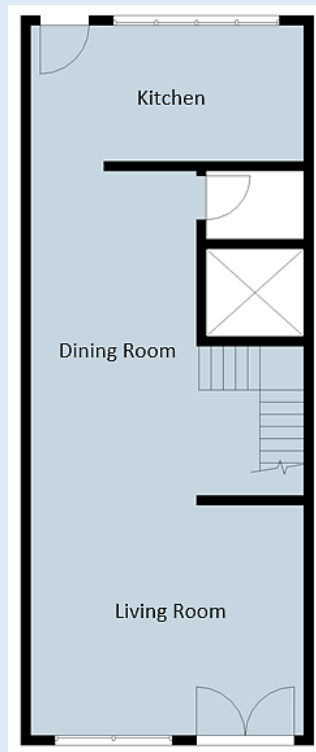

Figure G—XIV: An example of room with no full-height walls

Calculation of Openings for Natural Ventilation

Example 1:

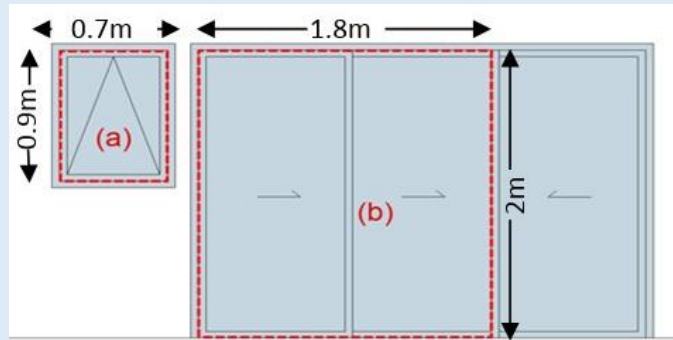

Figure G—XI: Elevation showing windows/openings of a room

1. Assume that the area of the above room is 75m^2 .
2. Effective area (a) of top-hung casement window that opens less than $30^\circ = 0\text{m}^2$
3. Effective area (b) of *sliding door = $2\text{m} \times 1.8\text{m} = 3.6\text{m}^2$
4. Total effective opening area = $0\text{m}^2 + 3.6\text{m}^2 = 3.6\text{m}^2$
5. Opening as a percentage floor area = $3.6\text{m}^2 / 75\text{m}^2 \times 100\% = 4.8\%$
(unacceptable)

Example 2:

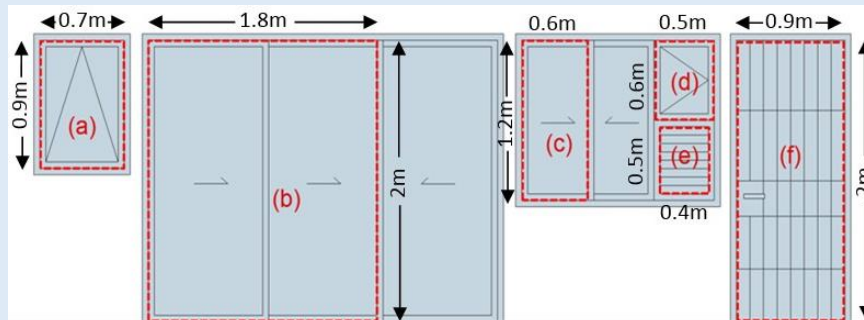

Figure G—XVI: Elevation showing windows/openings of a room

1. Assume that the area of the above room is 120m^2 .
2. Effective area (a) of top-hung casement window that opens less than $30^\circ = 0\text{m}^2$
3. Effective area (b) of *sliding door = $2\text{m} \times 1.8\text{m} = 3.6\text{m}^2$
4. Effective area (c) of sliding window = $1.2\text{m} \times 0.6\text{m} = 0.72\text{m}^2$
5. Effective area (d) of side-hung casement window that opens more than $30^\circ = (0.6\text{m} \times 0.5\text{m}) \times 50\% = 0.15\text{m}^2$
6. Effective area (e) of fixed louvers = $(0.5\text{m} \times 0.4\text{m}) \times 50\% = 0.1\text{m}^2$
7. Effective area (f) of *grille door = $2\text{m} \times 0.9\text{m} = 1.8\text{m}^2$
8. Total effective opening area = $0\text{m}^2 + 3.6\text{m}^2 + 0.72\text{m}^2 + 0.15\text{m}^2 + 0.1\text{m}^2 + 1.8\text{m}^2 = 6.37\text{m}^2$
9. Opening as a percentage floor area = $6.37\text{m}^2 / 120\text{m}^2 \times 100\% = 5.3\%$
(acceptable)

*opening to balcony, planter and service yard

G.3.2.2 All windows and openings intended for natural ventilation shall be located such that they open to –

- (a) the exterior of the building;
- (b) an airwell with a minimum width of 3.0m and a minimum area open to the sky complying with Table G.3.2.2(a); or
- (c) a recess, exceeding 3.0m from the external building wall, and of minimum width 3.0m. See Figure G.3.2.2(b) for illustration.

Height of airwell	Minimum airwell size (m ²)
Not more than 30 m	10
For each additional 3m height, or part of, beyond 30 m	Add 1 to the minimum size of 10

Table G.3.2.2(a) – Dimension of airwells

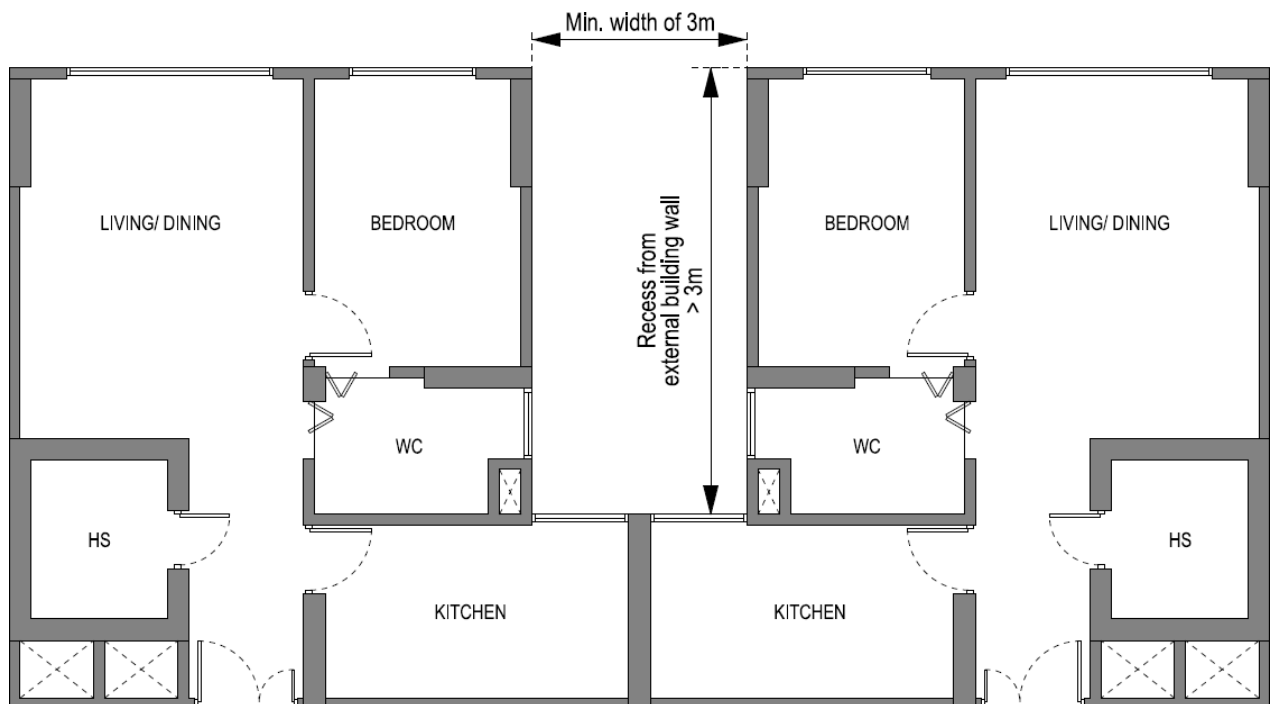

Figure G.3.2.2(b) – Recessed Void Dimension

Explanatory Notes G.3.2.2- Windows and openings

The location of the window/opening is acceptable if it is within 3m away from the external facade. For the purpose of measuring such distance, the presence of open yards, air-conditioning (A/C) ledges, or RC ledges will not be taken into consideration.

When **windows/openings open into a recess area of more than 3m distance** from the external building edge, the width of the recess shall be at least 3m.

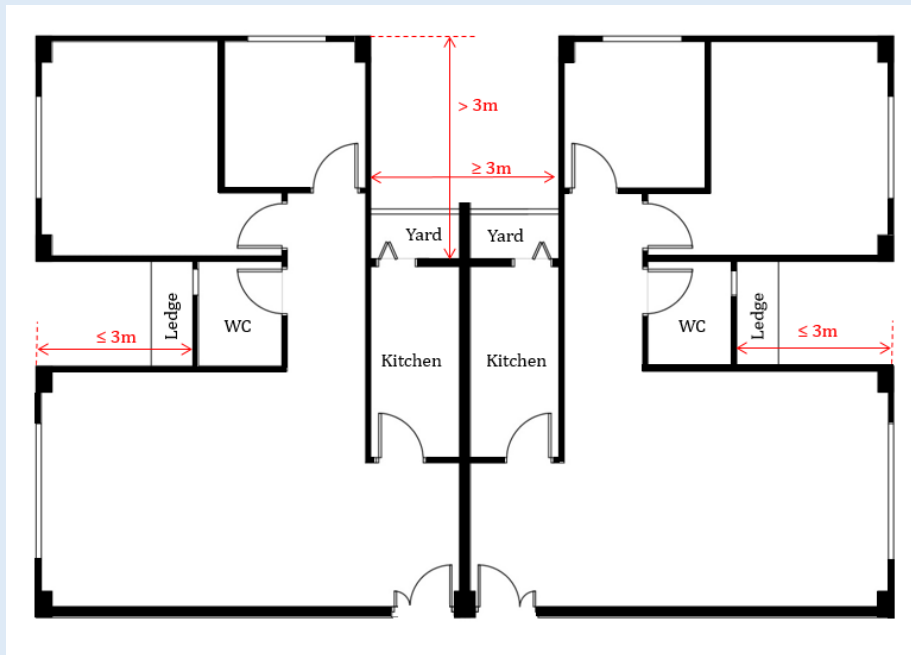

Figure G—XVII: Calculations of opening with yards, A/C ledges, RC ledges and recess areas

All air wells or voids (up to a height of 30m) serving as ventilation shafts shall have a minimum width of 3m (both A and B to be min. 3m respectively), and a minimum area of 10m². For every subsequent 3m height, the minimum air well size shall increase by 1m².

For example, an air well of 39.5m height shall have a minimum air well size of 14m².

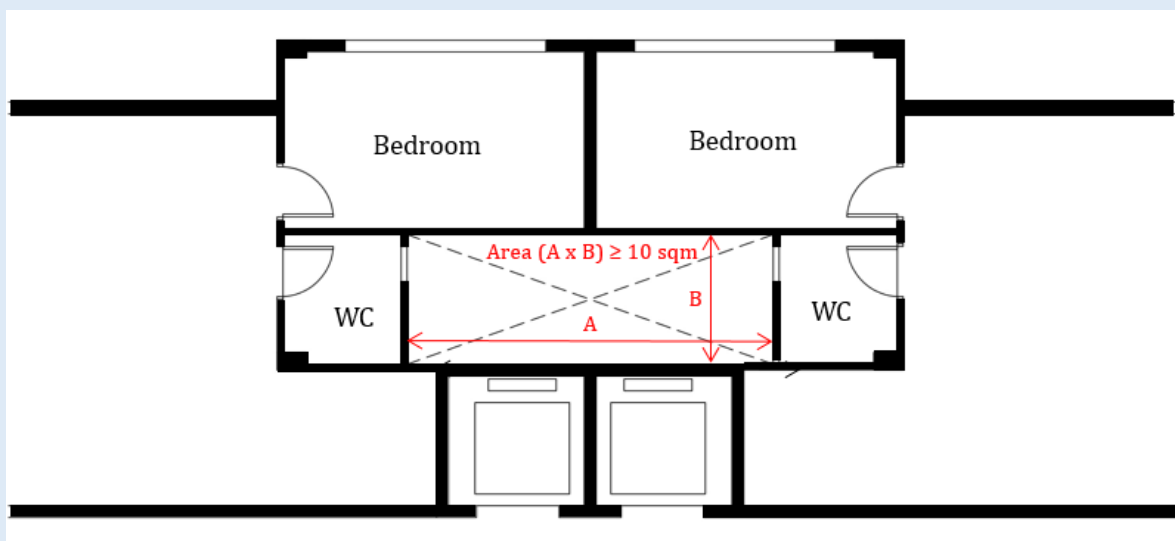

Figure G—XVIII: Calculations of air wells and voids

- G.3.2.3 No part of any room or space (other than a room in a warehouse) that is designed for natural ventilation shall be located more than 12 metres from any window or opening that is used to ventilate the room or space.

Explanatory Notes G.3.2.3 – Natural ventilation design

Typical floor plan of corridor layout: No parts of any room or space shall be more than 12m away from any ventilation openings ventilating that space.

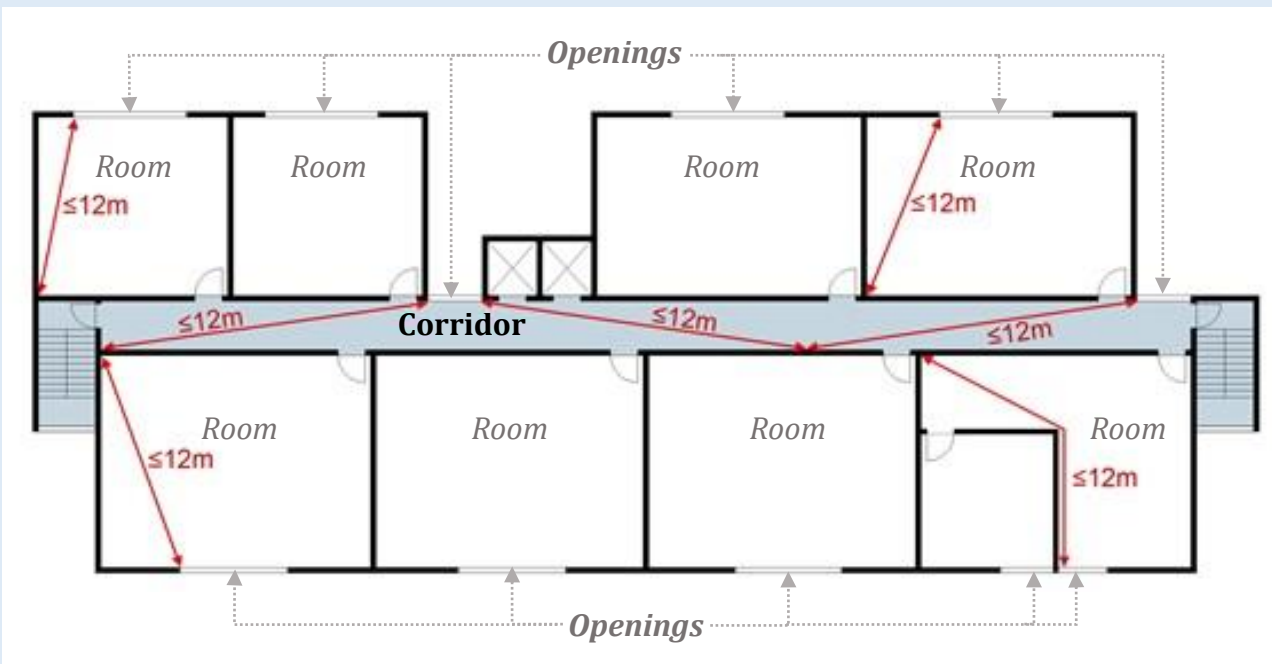

Figure G—XIX: Calculation of ventilation distance in sectional view

Note: For more information on ventilation requirements for lofts, please refer to Annex 1.

H SAFETY FROM FALLING**H.1 OBJECTIVE**

H.1.1 The objective of paragraphs H.2.1, H.2.1A and H.2.1B is to protect people from injury caused by falling from a height.

H.2 PERFORMANCE REQUIREMENT

H.2.1 Where there is a vertical drop in level of 1.0 m or more, appropriate measures shall be taken to prevent people from falling from a height.

H.2.1A Where a barrier is installed to prevent a person from falling from a height, the barrier –

- (a) must be sufficiently high to prevent a person from falling over the top of the barrier;
- (b) must not have any opening or gap that will allow a person to slip through the barrier; and
- (c) must not have any feature that facilitates a person in climbing over the barrier.

Site Observations H.2.1A (c) – Barriers shall not have features to allow climbability

Safety barriers shall not have features that allow climbing of the barrier.

Examples of barriers with horizontal elements that will facilitate climbing are shown below.



The horizontal members create a ladder-like effect that may entice children to climb, exposing them to the risk of falling from height.

Figure H—1: Climbable features posing risk of falling from height

H.2.1B Where glass is used as a part or whole of a barrier, the glass used shall be able to withstand the loading for which it is designed and shall not be susceptible to spontaneous breakage or to shattering.

Additional Clarifications H.2.1B – Laminated glass

Safety barrier laminated glass requirement is applicable to any house built for owner’s own use.



Figure H—II: Laminated glass (outdoor) in a house built for owner’s own use



Figure H—III: Laminated glass (indoor) in a house built for owner’s own use

H.2.2 The requirement in paragraphs H.2.1, H.2.1A and H.2.1B do not apply to –

- (a) any roof or maintenance area which is not easily accessible; and
- (b) any area where the provision of a barrier would prevent it from being used as intended, such as a loading dock or pier, platform for the loading or unloading of goods, or for boarding or alighting of passengers, stage for performance or entertainment, golf driving range, equipment pit and the like.

Explanatory Notes H.2.2 (a) – ‘Easily Accessible’ and ‘Not Easily Accessible’ areas

Examples of ‘Easily Accessible’ Areas

Examples of maintenance areas which are **easily accessible** to the public.
 Clauses H.2.1, H.2.1A and H.2.1B applies to these areas.



Figure H—IV: Door with padlock or a padlock gate to a maintenance area



Figure H—V: Staircase to the Roof



Figure H—VI: Accessible door opening to the maintenance roof through common space

Examples of ‘Not Easily Accessible’ Areas



Figure H—VII: One-way lock **and** self closing door / gate; with a signage to indicate maintenance area



Figure H—VIII: Locked-entry cat ladder / hatch doors; with signage to indicate maintenance area

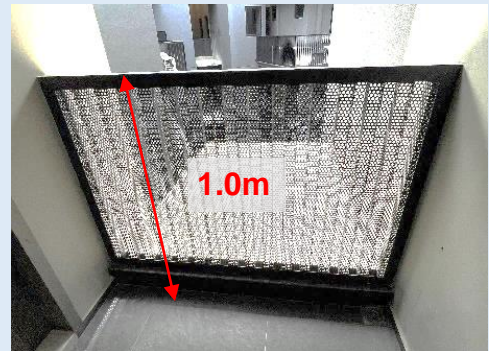

Figure H—IX: $\geq 1\text{m}$ wall / non-climbable barrier/ parapet

Site Observations H.2.2 (a) – Safety from falling at roof

Where staircases are used to access the roof via **padlock door or gate**, safety barriers shall be provided on the roof.



Figure H—X: Example of a roof with safety barriers

Site Observations H.2.2 (a) – Acceptable Solution

To prevent easy access to the public, door to maintenance area/roof shall have access control in the form of :

1. One-way lock or EM lock with self-closing mechanism, otherwise
2. Refer to Acceptable Solution of barriers under Approved Document Clause H.3

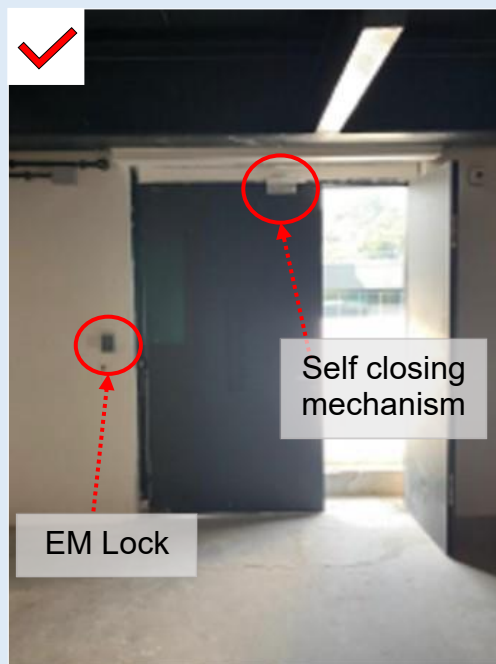

Figure H—XI: One-way or EM lock with self-closing mechanism

Additional Clarifications H.2.2 (a) – Full compliance for provision of safety barriers at ‘Not easily accessible’ areas

“Not easily accessible” maintenance area or roof is **not required** to provide a safety barrier. However, if a safety barrier is provided on a roof that is ‘not easily accessible’, **full compliance** for safety barriers must be adhered to.

This includes the compliance to the barrier gap opening size, height of barriers and provision of 75mm toeplate or kerb for the safety barrier.

Site Observations H.2.2 (b) – ‘Not easily accessible’ maintenance area



Access to this maintenance area to have one-way lock / EM lock with self-closing mechanism.

Figure H—XII: M&E floor openings without barriers

- H.2.3 The requirement in paragraph H.2.1A(a) does not apply to a barrier installed in any house built for the owner’s own use.
- H.2.4 The requirement in paragraph H.2.1A(b) does not apply to a barrier installed in any of the following places:
 - (a) any promenade or boardwalk at ground level along a waterfront;
 - (b) any houses built for the owner’s own use.

- H.2.5 The requirements under paragraph H.2.1A(c) does not apply to –
- (a) any industrial building;
 - (b) any promenade or boardwalk at ground level along a waterfront;
 - (c) any bay window in a residential unit;
 - (d) any house built for the owner's own use.

H.3 **ACCEPTABLE SOLUTION**

H.3.1 The requirement in paragraphs H.2.1, H.2.1A and H.2.1B is deemed to be satisfied if a barrier is provided in accordance with the specifications set out in paragraphs H.3.2 to H.3.5.

H.3.1A The requirements in paragraphs H.2.1, H.2.1A and H.2.1B are deemed to be satisfied for a safety barrier integrated with window at existing residential buildings, if such safety barrier is in accordance with the standardised design.

Note: For purposes of Regulation 2 of the Building Control Regulations 2003 and paragraph H3.1A, "standardised design" means the standardised design set out in Annex C in this Approved Document.

H.3.2 **Height of barrier**

H.3.2.1 The height of a barrier shall not be less than –

- (a) 1.0 metre; or
- (b) 900 mm at the lower edge of the window and gallery or balcony with fixed seating in areas such as theatres, cinemas and assembling halls.

Note: 1. The height of a barrier is measured vertically from the finished floor level to the top of the barrier.

2. The height of a barrier at the flight of stairs is measured vertically from the pitch line to the top of the barrier.

3. A kerb, protrusion or flat surface with dimensions more than 150 mm width by 150 mm length must be not less than 1000 mm away from the top of the barrier.

4. Where a kerb, protrusion or flat surface with dimensions more than 150 mm width by 150 mm length is provided next to a barrier, the height of the barrier shall be measured from the top of the kerb, protrusion or flat surface.

Site Observations H.3.2.1 – Height of barrier

Height of barriers

The height of a barrier is measured vertically from the finished floor level to the top of the barrier.

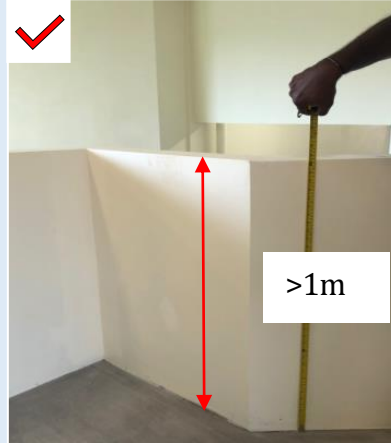

Figure H—XIII: Barrier height shall be 1m

The height of barrier at lower edge of window shall be not less than 900mm as shown below.



Figure H—XIV: Example of barrier at lower edge of window

The height of barrier in a theatre with fixed seating shall be at least 900mm in height.

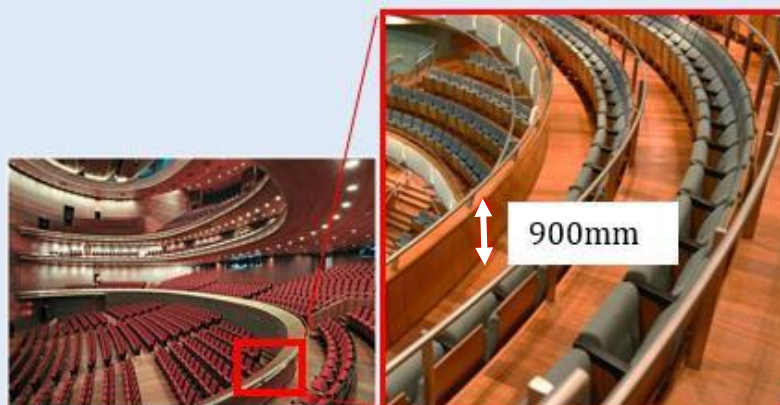

Figure H—XV: Example of barrier in a theatre

Site Observations H.3.2.1 – Height of barrier

Stepping surfaces to building edge

The Qualified Person shall ensure that planter boxes, walls, fixtures, landscape features, etc. do not form any stepping or climbable surfaces (with dimensions more than 150x150mm) to the building edge.

The height of the barrier adjacent to the stepping surface shall be at least 1m measured from the stepping surface.

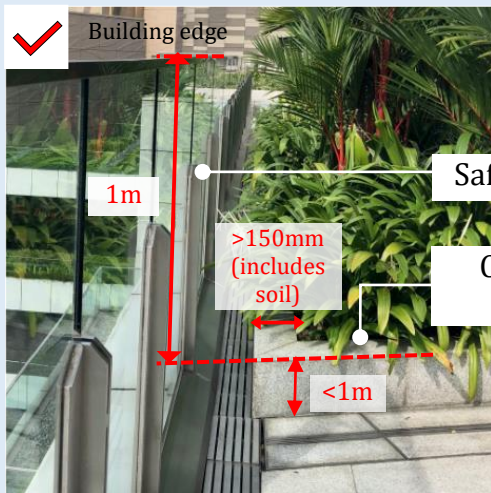

Figure H—XVI: Explanation of climbable surface

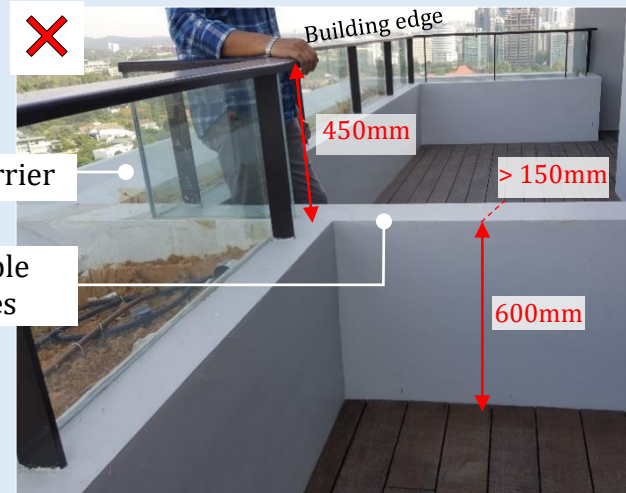

Figure H—XVII: Explanation of climbable surface with insufficient barrier height

Place fixtures, planter boxes, etc. that can form stepping surfaces away from the building edge.

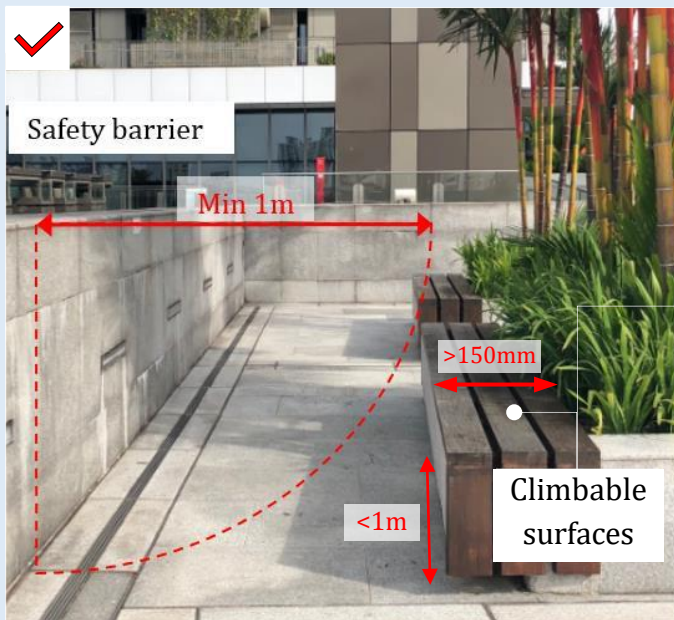

Figure H—XVIII: Explanation of flat climbable surface that is 1000mm away from the safety barrier along the building edge



Figure H—XIX: Explanation of flat climbable surface less than 1000 mm away from the top of the barrier

Note: For more information on safety from falling requirements for lofts, please refer to Annex 1.

Site Observations H.3.2.1 – Height of barrier

A kerb, protrusion or flat surface that is **more than 150mm wide** allows a person to walk on it.

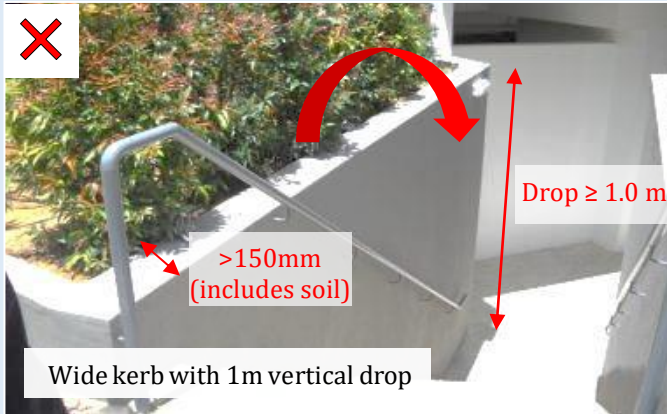

Figure H—XX: >1m vertical drop from the kerb poses as a safety issue



Figure H—XXI: Danger of fall from height



Figure H—XXII: Kerb along carpark ramp poses danger of falling from height

Additional Clarifications H.3.2.1 – Height of barrier for planters

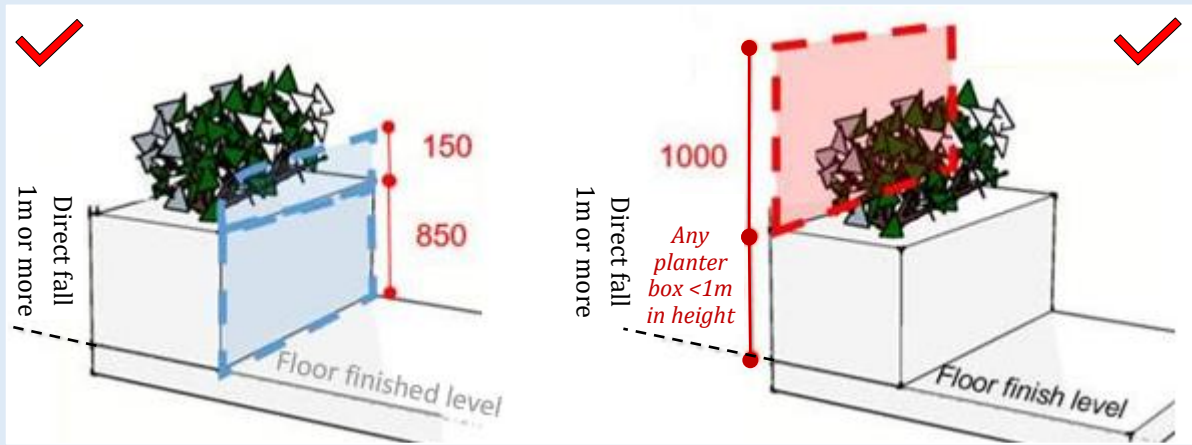

Figure H—XXIII: Provision of barriers for planters at height <1.0m

Site Observations H.3.2.1 – Height of barrier for planters



Figure H—XXIV: Site observation of planter areas with seatings

H.3.3 Horizontal loading and design of glass panel barriers

H.3.3.1 A barrier shall be designed to withstand a horizontal loading determined in accordance with SS EN 1991 Actions on structures – Part 1-1: General actions – Densities, self-weight, imposed loads for buildings and the associated Singapore National Annex.

H.3.3.1A Notwithstanding paragraph H.3.3.1, in the case of a barrier in a project where the first structural plans have been submitted for approval by the Commissioner of Building Control before 1 April 2015, the vehicular barrier may be designed to be capable of resisting forces set out in BS 6399: Part 1 - Loading for buildings. Code of practice for dead and imposed loads.

H.3.3.2 Glass panel barriers shall be designed and installed in accordance with Section 8 of BS 6180 – Barriers in and about Buildings – Code of Practice.

H.3.4 Size of opening

H.3.4.1 There must not be any gap, from the finished floor level to a height no less than 75 mm, at the lowest part of a barrier.

Note: This is to prevent objects from slipping through the base of the barrier and falling off into the space below.

Site Observations H.3.4.1 – No gap at 75mm from finished floor level



Figure H—XXV: No gap at 75mm from FFL is applicable to M&E areas

- H.3.4.2 The lowest 75 mm section of a bay window shall not be openable.
- H.3.4.3 The size of any opening or gap in a barrier must not be large enough as to permit the passage of –
- (a) in the case of non-industrial buildings, a 100 mm diameter sphere;
 - (b) in the case of industrial buildings, a 150 mm diameter sphere, or
 - (c) in the case of maintenance areas, including plants, equipment rooms, catwalks or maintenance platforms that are accessible only by authorised personnel, a 500 mm diameter sphere.
- H.3.4.4 For any flight of staircase –
- (a) the gap size between any two consecutive steps in a flight of staircases shall not be large enough as to permit the passage of –
 - (i) in the case of industrial buildings, a 150 mm diameter sphere, or
 - (ii) in the case of all other buildings, a 100 mm diameter sphere
 - (b) the size of any triangular opening, gap or void formed around a tread, riser and bottom edge of the barrier at a staircase in any building other than an industrial building shall not be large enough as to permit the passage of a 150 mm diameter sphere.

Site Observations H.3.4.4 – Opening or gap in a flight of staircase

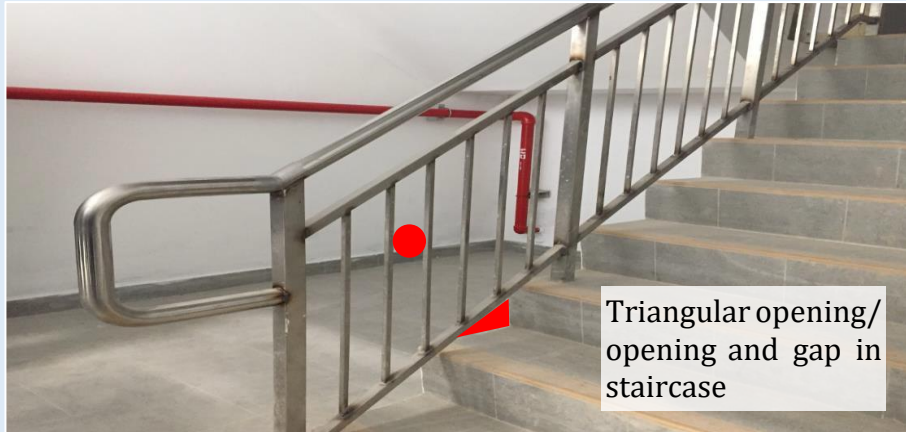

Figure H—XXVI: Opening or gap size in a flight of staircase



Figure H—XXVII: Gap size between consecutive steps

Gap size between steps

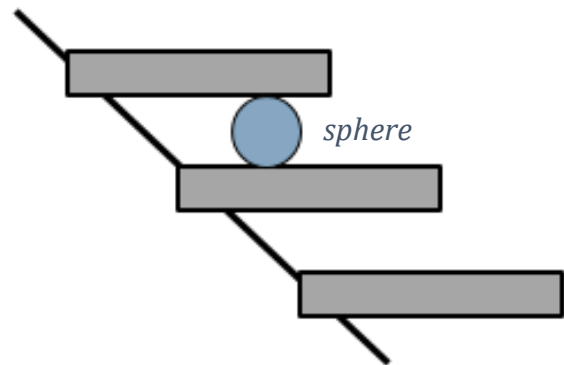

Figure H—XXVIII: Sectional view of gap size between steps

Note: In accordance with the Code on Accessibility in the Build Environment, stairs for ambulant disabled users shall be designed with no open risers.

H.3.4A Requirements to prevent climbing

H.3.4A.1 A barrier must have a height no less than –

- (a) the height specified in paragraph H.3.2.1, or
 - (b) 850 mm when measured from the last climbable toehold;
- whichever is higher.

See Figure H.3.4A.1(a) for illustration.

Note 1: A toehold means –

- (a) any opening in a perforated sheet or mesh having a horizontal dimension of more than 50 mm and a vertical dimension of more than 30 mm; or
- (b) any kerb or protrusion having a width of more than 50mm and has a chamfer gentler than 45° relative to the horizontal plane.

See Figures H.3.4A.1(b), H.3.4A.1(c) and H.3.4A.1(d) for examples on toehold dimensions.

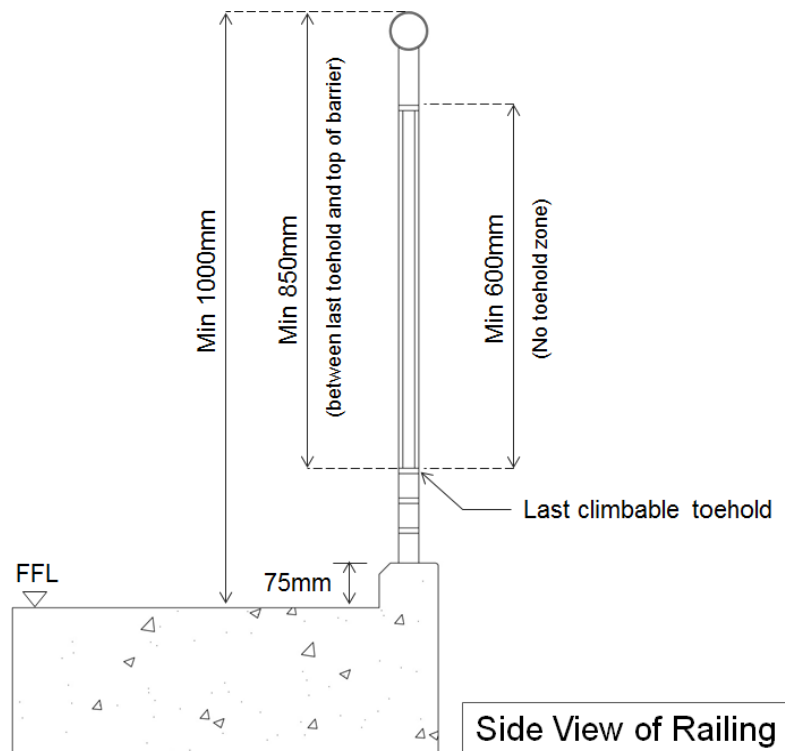

Figure H.3.4A.1(a) – Requirements to Prevent Climbing

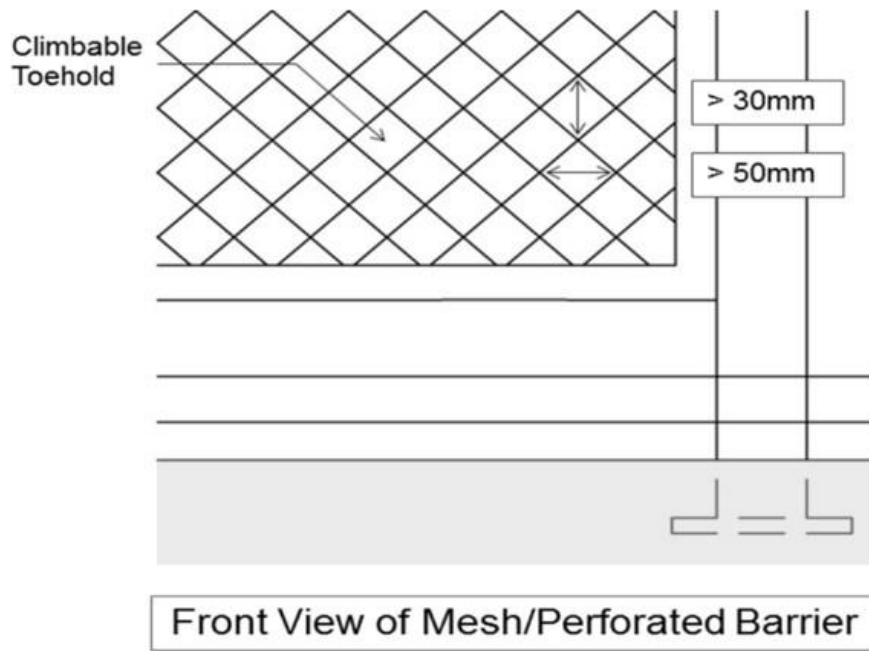

Figure H.3.4A.1(b) - Toehold Dimensions at Mesh/Perforated Barrier

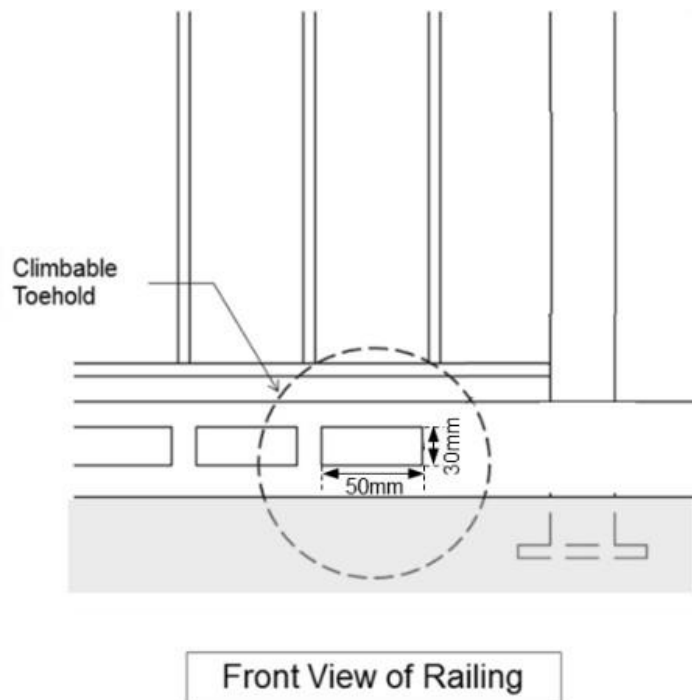

Figure H.3.4A.1(c) - Toehold Dimensions at Railing

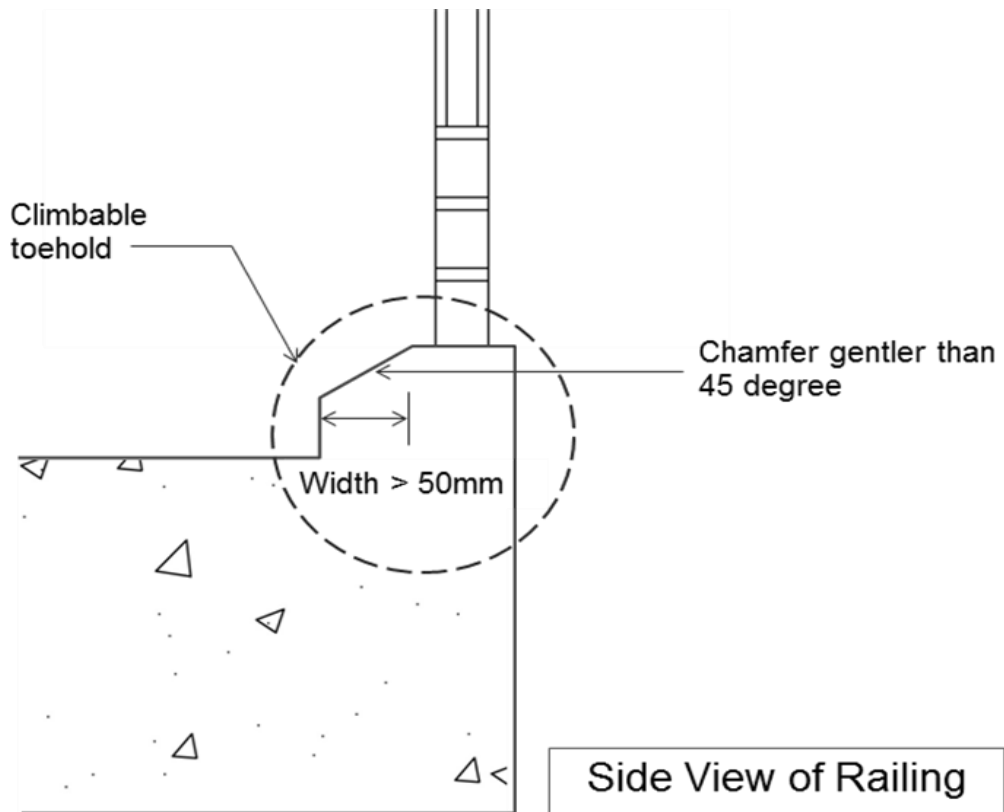

Figure H.3.4A.1(d) – Toehold Dimensions at Kerb/Protrusion

Note 2: A toehold is considered to be climbable if it is located within 600 mm vertically from –

- (a) *the finished floor level;*
 - (b) *a step; or*
- another climbable toehold.*

Site Observations H.3.4A – Toeholds, perforated barriers and protrusions

Toehold - any protrusion of more than 50mm in width with flat surface and sloping surface gentler than 45deg from the horizontal.

The perforated barrier is considered a toehold if the perforation has a horizontal dimension of than 50mm and a vertical dimension of more than 30mm:

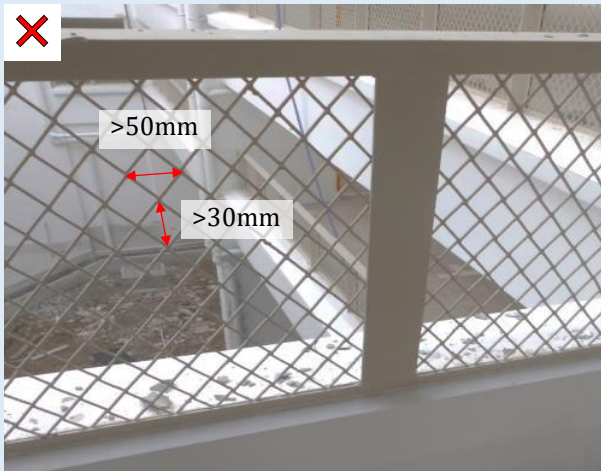

Figure H—XXIX: Climbable toehold of a perforated barrier

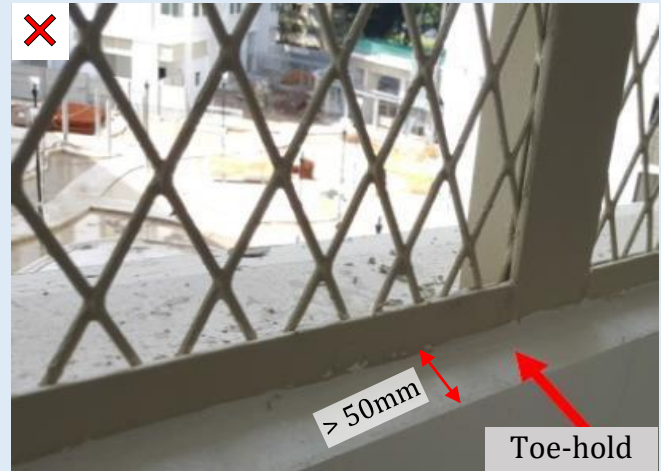

Figure H—XXX: An example of a toehold at a protrusion > 50mm width which is at height less than 600mm from floor level

Site Observations H.3.4A – Toehold observed on site

The image below illustrates how a toehold beneath a window that poses the risk of climbability and falling from height.

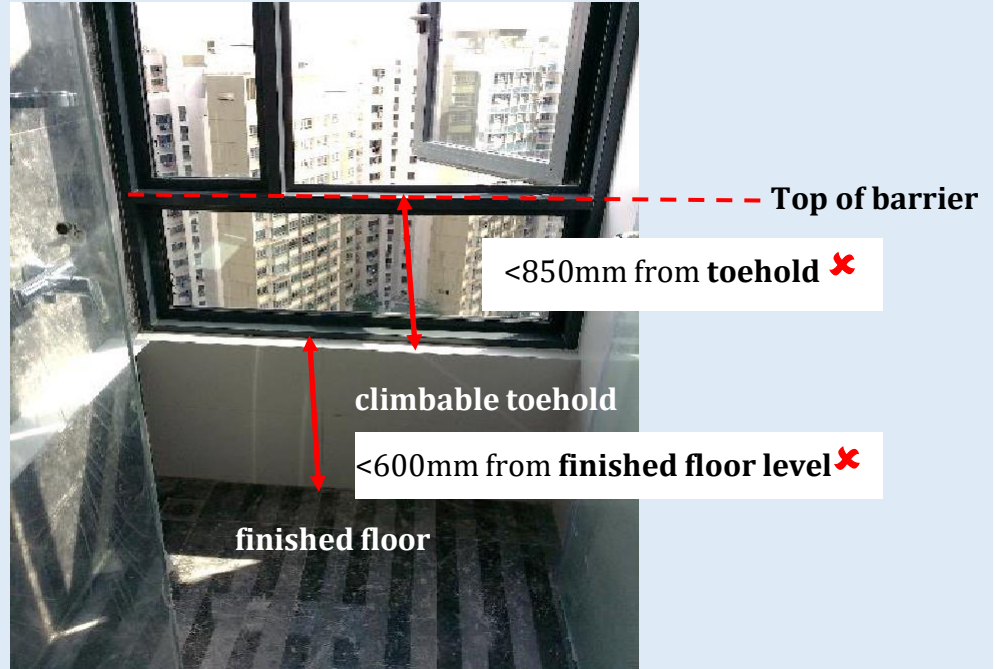

Figure H—XXXI: Explanation of climbable toeholds

Additional Clarifications

H.3.4A – Requirements on elevated pools along building edge

Do we regulate Infinity Pools?

Infinity pool is a swimming or reflecting pool located along the building edge that produces a visual effect of water extending to the horizon, vanishing or extending to infinity.

The use of inflatable float in an infinity edge swimming pool can be dangerous if the pool is located at a height and there is no safety barrier to stop the float from going over the pool edge.

Clause H: “Safety from Falling” will apply to any part of the perimeter of the pool if the elevation of the pool is **more than 1m above floor**.



Figure H—XXXII: Photograph of an infinity pool

1. For an elevated pool located along the building edge where there is a drop of more than 1m,
 - a) Raise the pool edge such that it is higher than the water level and provide a barrier beyond the pool; or/and
 - b) Provide a catch area of at least 600mm width as shown in the *Figure H- XXXIV*.

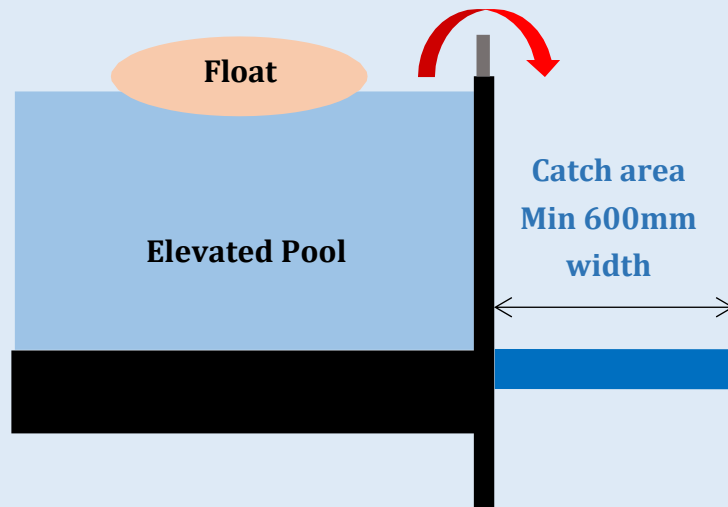

Figure H—XXXIII: Sectional diagram of infinity pool with catch area

2. Where the **pool wall along the building edge provides a foothold ($\geq 150\text{mm}$)**, safety barrier with a height of at least 1m shall be erected along the pool wall.

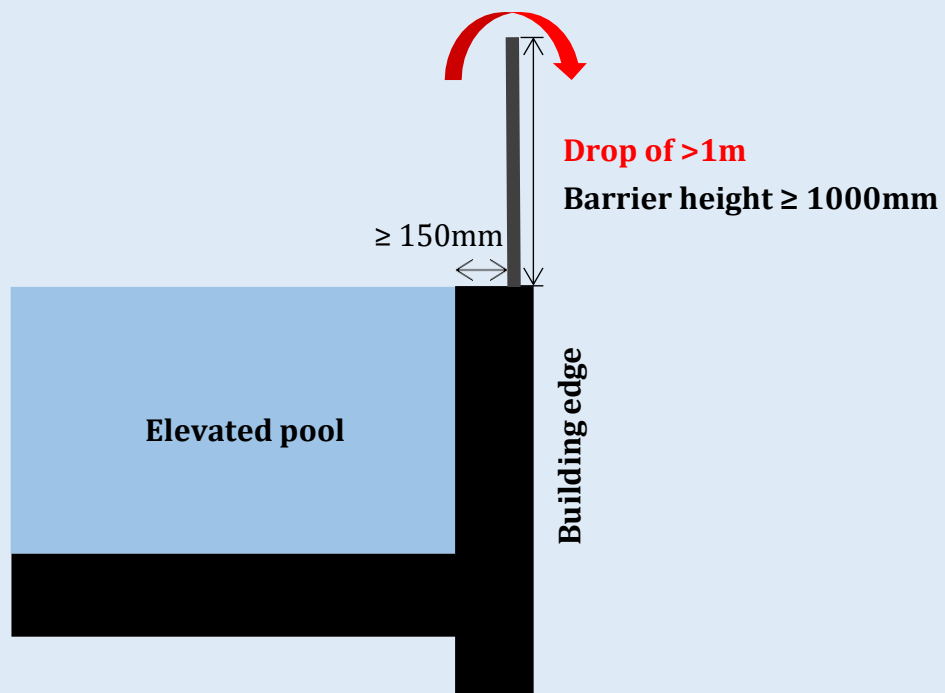

Figure H—XXXIV: Swimming pool with wide pool edge

H.3.5 **Glass Barrier**

- H.3.5.1 Where glass is used as a part or whole of a barrier, laminated glass shall be used.
- H.3.5.2 All glass used must comply with SS 341: Specification for Safety Glazing Materials for Use in Buildings.

Additional Clarifications H.3.5 – Glass barrier

Laminated glass shall be used where glass is used as a part or whole of a barrier.

In addition, Qualified Person should assess and address the risks arising once the glass is broken for various reasons. Where a free-standing glass barrier is used, a continuous rail should be fixed to the top edge of the glass in such a manner that the rail will:

1. remain in position when the glass panel breaks;
2. and does not fail if the design load is applied across the resulting gap.

Continuous fixing should be used for fixing the top rail to the glass barrier, as individual fixing points may create excessive stress concentrations on the glass panel.



Figure H—XXXV: An example of glass barrier with continuous rail fix to top edge of glass

I ENERGY EFFICIENCY

I.1 OBJECTIVE

I.1.1 The objective of paragraphs I.2.1 and I.2.2 is to facilitate efficient use of energy.

I.2 PERFORMANCE REQUIREMENT

I.2.1 A building shall be designed and constructed with energy conservation measures to reduce –

- (a) solar heat gain through the roof;
- (b) solar heat gain through the building envelope;
- (c) air leakage through doors, windows and other openings on the building envelope;
- (d) energy consumption of lighting, air-conditioning and mechanical ventilation systems; and
- (e) energy wastage through adequate provisions of switching means.

I.2.2 Commercial buildings with a gross area of more than 500 m² shall be installed or equipped with means to facilitate the collection of energy consumption data.

I.2.3 The requirement in paragraph I.2.1(a) does not apply to a roof of any of the following buildings that does not have air-conditioning:

- (a) any building with a gross floor area not exceeding 500 square metres;
- (b) any open-sided shed;
- (c) any linkway;
- (d) any covered walkway;
- (e) any store room and utility room;
- (f) any equipment or plant room.

I.3 ACCEPTABLE SOLUTION

I.3.1 The requirements in paragraphs I.2.1 and I.2.2 are deemed to be satisfied if the design and construction of a building comply with the specifications set out in paragraphs I.3.2 to I.3.8.

I.3.2 Air-conditioned building

- I.3.2.1 For all residential buildings with a gross floor area of 2000m² or more, the Residential Envelope Transmittance Value (RETV) of the building, as determined in accordance with the formula set out in the “Code on Envelope Thermal Performance for Buildings” issued by the Commissioner of Building Control, shall not exceed 25 W/m².
- I.3.2.2 The requirements in paragraphs I.3.2.1 are deemed to be satisfied if a residential building with external walls consisting of masonry construction, satisfies the criteria below:

$$\begin{aligned} &WWR_{\text{Bldg}} < 0.3 \text{ and } SC_{\text{facade}} < 0.7 \\ &\text{Or} \\ &WWR_{\text{Bldg}} < 0.4 \text{ and } SC_{\text{facade}} < 0.5 \\ &\text{Or} \\ &WWR_{\text{Bldg}} < 0.5 \text{ and } SC_{\text{facade}} < 0.43 \end{aligned}$$

Where: WR: Window to wall ratio
 SC: Shading coefficient of fenestration = SC_{glass} X SC_{shading device}

- I.3.2.3 For all non-residential buildings with an aggregate air-conditioned area of more than 500m², the Envelope Thermal Transfer Value (ETTV) of the building, as determined in accordance with the formula set out in the “Code on Envelope Thermal Performance for Buildings” issued by the Commissioner of Building Control, shall not exceed 50 W/m².
- I.3.2.4 In respect of roofs with skylight, the roof thermal transfer value (RTTV) as determined in accordance with the formula set out in the “Code on Envelope Thermal Performance for Buildings” issued by the Commissioner of Building Control, shall not exceed 50 W/m².
- I.3.2.5 In respect of roofs without skylight, the average thermal transmittance (U- value) for the gross area of the roof shall not exceed the limit prescribed in Table I1 for the corresponding weight group.

TABLE I1

Maximum thermal transmittance for roof of air-conditioned building

Weight group	Weight range (kg/m ²)	Maximum thermal transmittance (W/m ² K)
Light	Under 50	0.5
Medium	50 to 230	0.8
Heavy	Over 230	1.2

Note 1 The requirements in paragraphs I.3.2.3 to I.3.2.5 apply to buildings with a gross floor area exceeding 500 m².

- 2 *In the case of semi-detached, terraced and linked houses, each unit of the semi-detached, terraced or linked houses is construed as a building for the purpose of the above note (1).*

I.3.3 Non air-conditioned building

I.3.3.1 The thermal transmittance (U-value) of the roof, as determined in accordance with the formula set out in the “Code on Envelope Thermal Performance for Buildings” issued by the Commissioner of Building Control, shall not exceed the limit specified in Table I2 for the corresponding weight group.

TABLE I2

Maximum thermal transmittance for roof of non air-conditioned building

Weight group	Weight range (kg/m ²)	Maximum thermal transmittance (W/m ² °K)
Light	Under 50	0.8
Medium	50 to 230	1.1
Heavy	Over 230	1.5

Note Where a building is partially air-conditioned and the aggregate air-conditioned area is less than 500 m², the requirement in paragraph I.3.3.1 shall apply if the total gross floor area of the building exceeds 500 m².

I.3.4 Air tightness and leakage

I.3.4.1 All windows on the building envelope shall not exceed the air leakage rates specified in SS 212 – Specification for Aluminium Alloy Windows.

I.3.4.2 Where the door opening of any commercial unit is located along the perimeter of the building envelope, that unit shall –

- (a) be completely separated from the other parts of the building; and
- (b) has its air-conditioning system separated from and independent of the central system.

Note 1 *The requirements in paragraphs I.3.4.1 and I.3.4.2 do not apply to non air-conditioned buildings.*

2 *The requirement in paragraph I.3.4.2 also applies to commercial units, the doors of which open into an exterior open space, external corridor, passageway or pedestrian walkway.*

I.3.5 Air-conditioning system

I.3.5.1 Where the cooling capacity of any air-conditioning system exceeds 30 kW, the equipment shall comply with the relevant provisions of SS 530 - Code of Practice for Energy Efficiency Standard for Building Services and Equipment.

I.3.6 Artificial lighting

I.3.6.1 The maximum lighting power budget in a building shall comply with SS 530 - Code of Practice for Energy Efficiency Standard for Building Services and Equipment.

I.3.7 Switching control

I.3.7.1 Air-conditioning system shall be equipped with manual switches, timers or automatic controllers for shutting off part of the air-conditioning system during periods of non-use or reduced heat load.

I.3.7.2 Lighting control for artificial lighting shall be provided in accordance with SS 530 - Code of Practice for Energy Efficiency Standard for Building Services and Equipment.

I.3.7.3 In any hotel building, a control device acceptable to the Commissioner of Building Control, shall be installed in every guestroom for the purpose of automatically switching off the lighting and reducing the air-conditioning when a guestroom is not occupied.

I.3.8 Energy auditing

I.3.8.1 For buildings used as offices, shops, hotels or a combination thereof, suitable means for the monitoring of energy consumption shall be provided to all incoming power supply to a building and the sub-circuits serving –

- (a) a central air-conditioning system;
- (b) a major mechanical ventilation system;
- (c) a vertical transportation system;
- (d) a water pumping system;
- (e) the general power supply to tenancy areas;
- (f) the general lighting supply to tenancy areas;
- (g) the general power supply to owner's premises; and
- (h) the general lighting supply to owner's premises.

J ROOF

J.1 OBJECTIVE

J.1.1 The objective of paragraph J.2.1 is to protect the roof of semi-detached houses, terraced houses and linked houses from physical damage when repairs, alterations or additions to the roof of an adjoining house are being carried out.

J.2 PERFORMANCE REQUIREMENT

J.2.1 The roof shall be designed and constructed such that the roof of every house is separate and independent of each other.

J.3 ACCEPTABLE SOLUTION

J.3.1 The requirement in paragraph J.2.1 is deemed to be satisfied if the party wall is extended above the level of the roof so that each roof is separate and independent of the roof of the adjoining house.

K LIFTS AND ESCALATORS

K.1 OBJECTIVE

K.1.1 The objectives of paragraphs K.2.1, K.2.2, K.2.3 and K.2.4 are to provide a convenient means of vertical transportation and to protect people from injury while using the lifts or escalators.

K.2 PERFORMANCE REQUIREMENT

K.2.1 Lifts and escalators shall –

- (a) move people safely; and
- (b) not produce excessive acceleration or deceleration.

K.2.2 A building comprising 5 or more storeys (including the ground level) shall be provided with one or more passenger lifts.

Additional Clarifications K – Car Lift

Requirement on car lifts which convey driver/ passengers

A car lift is intended to convey vehicles together with driver and/or passengers during operation. The requirements under **Section K** shall apply.



Figure K—I: Car lift intended to convey vehicles together with driver/ passengers

Note: For more information on Mechanised Car Parking System, please refer to Annex 2.

- K.2.3 All lift interior fittings and fixtures must be securely fastened by appropriate mechanical fasteners.
- K.2.4 The requirement in paragraph K.2.1 does not apply to any stairlift or vertical platform lift that –
- (a) has a maximum vertical displacement of less than 1,000 mm when the lift is in operation;
 - (b) has a maximum obstruction force of less than 150 Newtons when the lift is in operation; and
 - (c) serves a single residential unit.
- K.2.5 In paragraph K.2.4, “stairlift” and “vertical platform lift” have the same meanings given to them in regulation 2(1) of the Building Maintenance and Strata Management (Lift, Escalator and Building Maintenance) Regulations 2016 (G.N. No. S 348/2016).
- K.3 **ACCEPTABLE SOLUTION**
- K.3.1 The requirements in paragraphs K.2.1 and K.2.2 are deemed to be satisfied if –
- (a) the lifts are designed and installed:
 - (i) in accordance with the requirements of SS 550 - Code of Practice for Installation, Operation and Maintenance of Electric Passenger and Goods Lifts;
 - (ii) with light curtain installed at the lift door as a door protective device that shall automatically initiate re-opening of the door(s) in the event of a person crossing the entrance during the closing movement, and that the light curtain shall have its nudging mode de-activated if nudging mode is provided; and
 - (iii) provided with a video recorder that has the following minimum specifications –
 - a. Capacity to record 24 hours a day, 7 days a week;
 - b. Capture footage of the entire lift car including in-car floor indicator, lift car door(s) and landing area outside the lift car in front of the lift doors;
 - c. Frame rate of at least 6 frames per second;
 - d. Video resolution of at least 352 x 240 pixels or CIF CCTV resolution; and
 - e. Storage of video footage for at least 30 days;

and

- (b) the escalators are designed and installed:
 - (i) in accordance with SS 626 - Code of Practice for Design, Installation and Maintenance of Escalators and Moving Walks;
 - (ii) with means to limit or detect the riser end of the step being displaced upward by more than 5mm at the upper and lower transition curves at or prior to the point of tangency of the horizontal and curved track. When the upward displacement exceeds 5mm, the means shall cut off the power to the driving machine and brake and stop the escalator before the detected step reaches the comb plate with any load up to brake rated load with escalator running; and
 - (iii) provided with a video recorder that has the following minimum specifications –
 - a. Capacity to record 24 hours a day, 7 days a week;
 - b. Capture footage of the entire length of escalator, including landing floor plates on both the upper and lower landing areas of the escalator;
 - c. Frame rate of at least 6 frames per second;
 - d. Video resolution of at least 352 x 240 pixels; or CIF CCTV resolution; and
 - e. Storage of video footage for at least 30 days.

For the purposes of this part:

“light curtain” means an opto-electronic device that is usually mounted at the lift doors to detect the presence of objects in the path of its light rays.

K.3.2

The requirements in paragraphs K2.1 are deemed to be satisfied if vertical platform lifts and stairlifts which are primarily designed for persons with impaired mobility are designed and installed in accordance with the requirements of –

- (a) EN 81-41 – Safety rules for the construction and installation of lifts – Special lifts for the transport of persons and goods. Part 41: Vertical platforms intended for use by persons with impaired mobility; or
- (b) EN 81-40 – Safety rules for the construction and installation of lifts – Special lifts for the transport of persons and goods. Part 40: Stairlifts and inclined lifting platforms intended for persons with impaired mobility; or
- (c) ASME A18.1 – Safety standard for platform lifts and stairway chairlifts; or

- (d) Code of Practice for installation, operation and maintenance of vertical platform lift with enclosed platform and automatic sliding doors; or
- (e) other relevant standards which are acceptable to the Commissioner of Building Control; and
- (f) except for stairlifts and chairlifts, with a telephone, intercom system or any other communication device that enables notification or direct communication with personnel who can initiate an emergency response; and
- (g) for vertical platform lifts that are not installed in private homes solely for the use of the occupants, in addition to the above standards, they are provided with a video recorder that has the following minimum specifications –
 - (i) Capacity to record 24 hours a day, 7 days a week;
 - (ii) Capture footage of the entire lift platform and platform entrance, from floor to ceiling (if any), and landing area outside the lift platform in front of the landing doors;
 - (iii) Frame rate of at least 6 frames per second;
 - (iv) Video resolution of at least 352 x 240 pixels or CIF CCTV resolution; and
 - (v) Storage of video footage for at least 30 days.

For the purposes of this part:

“stairlift” means a motorised platform or seat installed in a stairway, which traverses the stairs when activated; and

“vertical platform lift” means a vertical lifting platform intended for use by people with impaired mobility, with or without wheelchair, travelling vertically between predefined levels along a guided path.

Site Observations K.3.2 – Stairlift

For existing buildings, and in exception circumstances for new developments with particular constraints, where a passenger lift cannot be accommodated, a wheelchair stair lift can be considered as a reasonable alternative for vertical circulation within the building.



Figure K—II: Examples of stairlifts

Note: For more information on stair lift, please refer to Clause 4.10.3 in the Code on Accessibility 2019.

- K.3.3 The requirements in paragraph K2.1 are deemed to be satisfied if home lifts are designed and installed in accordance with the requirements of –
- (a) the SS 550 - Code of Practice for Installation, Operation and Maintenance of Electric Passenger and Goods Lifts; or
 - (b) other relevant standards which are acceptable to the Commissioner of Building Control.
 - (c) With a telephone, intercom system or any other communication device that enables notification or direct communication with personnel who can initiate an emergency response.

For the purposes of this part:

“home lift” means a lift, excluding a stairlift or a vertical platform lift, not being common property, installed in a private home solely for the use of its occupants.

- K.3.4 The requirements in paragraph K2.3 are deemed to be satisfied if the mechanical fasteners are provided in accordance with the following:
- (a) Mechanical fasteners are devices that can transmit mechanical load, keeping two or more elements of an assembly of fittings and fixtures in relative position, assuring continuity, stability and mechanical strength as needed.
 - (b) The fittings and fixtures must not be at risk of dislodging from its intended position, and the strength of the fastening means must not become undone, neither with the application of reasonable force, nor with the passage of time.
 - (c) Examples of mechanical fasteners include bolts and nuts, screws, pins and rivets.

L LIGHTNING PROTECTION

L.1 OBJECTIVE

L.1.1 The objective of paragraph L.2.1 is to protect a building from the direct effects of lightning strike and to protect its occupants from the risk of lightning current being discharged through the building.

L.2 PERFORMANCE REQUIREMENT

L.2.1 A lightning protection system shall be capable of protecting the building and its occupants from the effects of lightning strike.

L.3 ACCEPTABLE SOLUTION

L.3.1 The requirement in paragraph L.2.1 is deemed to be satisfied if the lightning protection system is designed and installed in accordance with SS 555 - Code of Practice for Protection Against Lightning.

Additional Clarifications L – Lightning Protection System Design

Good Practices in Lightning Protection System Design (LPS)

Habitable Rooftop Spaces (e.g. roof gardens, penthouse terraces)

1. Typically, rooftop spaces are intended to be accessed only for maintenance purposes. With increasing prevalence of building designs with habitable rooftop spaces, e.g. gardens, penthouse open terrace, car park and amenities. It is important that the LPS design of such buildings take into account such habitable rooftop spaces so as to protect occupants and users of the buildings against the risk of lightning.
2. For such habitable rooftop spaces, Architects need to work closely with the Electrical Engineer and Structural Engineer to ensure that these spaces are designed in accordance with the requirements of SS555, similar to any other habitable open spaces. LPS provision should be carefully considered in the initial design of a building, to integrate both architectural and structural elements into the LPS design. In doing so, this will improve the overall aesthetic of the architectural design and the effectiveness of the LPS.
3. The LPS design may use overhead protection structures in the form of trellis, higher surrounding structures, lightning rods or catenary wires to ensure such habitable open spaces falls within protected zones established by the LPS air termination where applicable. Exposed metal fixtures such as railings, staircases, windows, antenna and MEP services (e.g. ducts, pipes, cable containments) exposed to direct lightning strike should all be connected to the LPS in accordance with SS555.



Figure L—1: Examples of overhead protection

4. The LPS design should also ensure that air termination elements and conductors of the LPS such as exposed lightning tape, are not located within easy reach of users of these habitable rooftop spaces. Where building design poses constraints, insulation of exposed lightning tape should be provided in accordance with SS555 to prevent direct user contact.

Protection of vertical sides of tall buildings

1. For tall buildings, protection against lightning flashes to the vertical sides of the building with air termination system shall be provided down to a height of 48m in accordance with SS555. The LPS design shall also ensure that every lateral external metallic fixtures (windows, balcony railing, façade) touched by the rolling sphere is bonded to the LPS.

Use of Aluminium Tape

2. Aluminium tape is used widely in local industry practice as LPS conductors in air termination and down conductor system. While not required for mandatory compliance, SS555 advises that aluminium tape should not be attached directly to calcareous building surfaces such as concrete, limestone and plaster as this may hasten the corrosion of the aluminium tape. Additionally, SS555 specifically prohibits the embedding of bare aluminium tape within concrete elements of the building and in earth except if these are completely sleeved with a durable, close-fitting insulating sleeve.
3. As a precaution, mitigation measures in the LPS design should be taken to prevent the direct contact of the aluminium tape with bare calcareous building surfaces as far as possible, such as with the use of saddles at closer intervals or painting of the surfaces. Alternatively, SS555 advises that the potential corrosion effect may be reduced through increases in material size, using corrosion resistive components, or taking other corrosion protection measures. During the lifecycle of the building, more regular inspection intervals of the LPS than the recommended intervals required under SS555 may be implemented to ensure the continued integrity of the LPS.

Maintaining proper records of LPS during construction

1. As a good practice, the developer and the Qualified Person appointed to supervise the installation of the LPS should co-ordinate with the main builder to keep and maintain proper records of the following documents throughout the project.
 - a) LPS as-built plans endorsed by the QP (electrical).
 - b) Photos of all concealed equipotential bonding between metal fixtures, steel rebars of concrete and LPS. Metal fixtures may include railings, staircases, windows, antennae, façade and M&E services (e.g. ducts, pipes, cable containments).
 - c) Earth Resistance & Continuity Test Form
 - d) LPS Material Test Report [Test in accordance with EN50164]

Regular Inspection and Maintenance of LPS, Operation & Maintenance (O&M) Manual

1. Building owners, MCSTs and facility managers are reminded to conduct regular inspection and maintenance of the LPS in accordance with the requirements specified under SS555, to ensure continued integrity of the LPS throughout the building's life cycle. As-built LPS drawings and Test Records should be made available to the person responsible to maintain the LPS.
2. Should there be extensions or alterations to the building, a Professional Electrical Engineer should be appointed to verify that the LPS protects the new areas, and to enhance the LPS to protect these new areas where necessary, in accordance with SS555.
3. LPS's documents should be prepared and filed in the M&E O&M Manual to facilitate LPS inspections and maintenance. They should contain sufficient information to guide the inspector through the inspection process so that all areas of importance are documented. Some of the documents are Certificate of Supervision of Lightning Protection System, As-Built Drawings, Test Records including photographs of all concealed equipotential bonding between metal fixtures, steel rebars of concrete and LPS.
4. The LPS should be maintained regularly to ensure that it does not deteriorate but continues to fulfil the requirements in accordance to SS555 to which it was originally designed. Any alteration works to the existing LPS should be incorporated into the O&M Manual.

M SAFETY OF WINDOWS

M.1 OBJECTIVE

M.1.1 The objective of paragraphs M.2.1 and M.2.2 is to protect people from injury caused by falling windows.

M.2 PERFORMANCE REQUIREMENT

M.2.1 A window system shall be adequately designed and constructed with appropriate materials for its intended use.

M.2.2 A window system shall have –

- (a) window components, including fasteners, fixings, hinges and stays of adequate number, size and strength to safely support the weight of the window system and other loads imposed on it;
- (b) a structural frame profile that is of adequate size and strength and adequately reinforced at locations where screws or rivets are to be affixed; and
- (c) features and components to prevent the window from detaching, dislodging or falling during its intended use.

M.3 ACCEPTABLE SOLUTION

M.3.1 In the case of an aluminium alloy window, the requirements in paragraphs M.2.1 and M.2.2 are deemed to be satisfied if such window is designed and constructed in accordance with SS 212 – Specification for Aluminium Alloy Windows.

Site Observations M.2.2 Window Fasteners

Examples of window components:

Fasteners such as screws and rivets made of stainless steel as shown in *Figure M—1* is acceptable.



Figure M—1: Window fasteners

Site Observations M.2.2 Safety stoppers and Deep-seated tracks

Examples of features and components to prevent sliding windows from detaching, dislodging or falling:

1. Safety Stoppers
2. Deep seated tracks



Figure M—II: Sliding windows

N USE OF GLASS AT HEIGHT**N.1 OBJECTIVE**

N.1.1 The objective of paragraph N2 is to protect persons from injury cause by spontaneous breakage of glass elements at height and by falling glass panels resulting from bond failure of structural sealant.

N.2 PERFORMANCE REQUIREMENT

N.2.1 Where glass is used as a part or whole of the facade, roof, canopy or other type of overhead glazing of a building located at height of 2.4 metres or more, whether situated within the interior or forming the exterior of a building, appropriate measures shall be taken to minimise the risk of injury to people in the event of spontaneous breakage of such glass elements.

N.2.2 Where structural sealant glazing is used in a glass curtain wall or other glass installation located at a height of 2.4 metres or more, whether situated within the interior or forming the exterior of a building, appropriate measures shall be taken to minimise the risk of injury to people in the event of falling glass panels resulting from bond failure of the structural sealant.

N.3 ACCEPTABLE SOLUTION**Spontaneous breakage of glass**

N.3.1 The requirement in paragraphs N.2.1 is deemed to be satisfied if the specifications set out in paragraphs N.3.2 to N.3.4 are complied with.

N.3.2 Except as provided in N.3.3, float (or annealed) glass, heat strengthened glass, laminated glass or other type of glass that is not prone to spontaneous breakage shall be used as the glass material at height.

N.3.3 Where monolithic tempered glass, heat-soaked tempered glass or other types of glass that are prone to spontaneous breakage is used in the facade, roof, canopy or other type of overhead glazing located at a height of 2.4 metres or more, the design of the facade, roof, canopy or overhead glazing shall provide for suitable protection such as installation of screens or shields to protect people from any injury in the event of breakage of such glass elements at height.

N.3.4 Where the glass is used as a part or whole of the facade, roof, canopy or other type of overhead glazing, the glass used shall comply with SS 341: Specification for Safety Glazing Materials for Use in Buildings.

Site Observations N.2.1 – Use of glass at height



Figure N—II: Example of glass panels at commercial areas

Glass panel above 2.4m from finished floor level shall have appropriate measures to minimize the risk of injury to people in the event of spontaneous breakage of such glass elements, such as using laminated glass.

Single glass panel extending from 1st storey to above 2.4m shall have appropriate measures to minimize the risk of injury to people in the event of spontaneous breakage of such glass elements, such as using laminated glass.

Falling glass resulting from bond failure of the structural sealant

N.3.5 The requirement in paragraph N.2.2 is deemed to be satisfied if the specifications set out in paragraphs N.3.6 to N.3.8 are complied with.

- N.3.6 The structural sealant glazing (SSG) shall be constructed to be of
- (a) two-sided SSG type; or
 - (b) four-sided SSG type with retaining devices that are to be designed and constructed to prevent any fall of façade panels in the event of bond failure of the structural sealant.

Note: The requirement in paragraph N.3.6(b) is illustrated in Figure N1.

N.3.7 Mechanical self-weight supports shall be provided for all glass panels of the SSG.

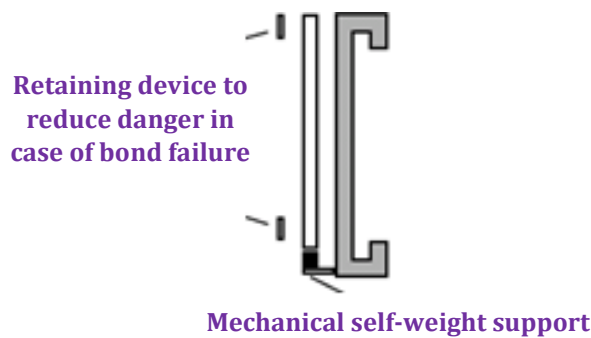

Figure N1 – Four-sided SSG with mechanical self-weight and retaining devices

- N.3.8 The SSG shall be designed and constructed in accordance with the following Standards –
- (a) ASTM C1184: Standard Specification for Structural Silicone Sealants and ASTM C1401: Standard Guide for Structural Sealant Glazing; or
 - (b) BS EN 13022-2: Glass in Building - Structural Sealant Glazing and BS EN 15434: Glass in Building – Product Standard for Structural and/or Ultraviolet Resistant Sealant.

O PROTECTION FROM INJURY BY VEHICLES IN BUILDINGS**O.1 OBJECTIVE**

O.1.1 The objectives of paragraphs O.2.1 and O.2.2 are to protect people from injury caused by a vehicle breaching designated spaces for vehicular access in a building.

O.2 PERFORMANCE REQUIREMENT

O.2.1 Where the whole or part of a floor of a building allows vehicular access, such as a vehicle park or a ramp or route for vehicular access, appropriate barriers shall be installed to prevent vehicles from breaching the perimeter of the floor of the building.

O.2.2 Where any part of a building allows vehicular access near an area where people are likely to be present, such as passenger pick-up point, vehicle park lift lobby and the like, appropriate measures shall be taken to prevent vehicles from encroaching into such areas.

O.3 ACCEPTABLE SOLUTION

O.3.1 The requirements in paragraphs O.2.1 and O.2.2 are deemed to be satisfied if a barrier is provided in accordance with the specifications set out in paragraph O.3.2.

O.3.2 Horizontal loading of barrier

O.3.2 The vehicular barrier should be capable of resisting forces set out in SS EN 1991.

O.3.3 Notwithstanding paragraph O.3.2, in the case of a vehicular barrier in a project where the first structural plans have been submitted for approval by the Commissioner of Building Control before 1 April 2015, the vehicular barrier may be designed to be capable of resisting forces set out in BS 6399- Part 1: Loading for Buildings. Code of Practice for Dead and Imposed Loads.

P DAYLIGHT REFLECTANCE**P.1 OBJECTIVE**

P.1.1 The objective of paragraph P.2.1 is to protect occupants of buildings in the vicinity of a building from loss of amenity caused by the reflection of sunlight off the external surface of that building, arising from the use of materials with high daylight reflectance.

P.2 PERFORMANCE REQUIREMENT

P.2.1 The external surface (including a roof) of a building must be designed and constructed in a manner such that any reflection of sunlight off the external surface of the building does not result in loss of amenity to occupants of other buildings in the vicinity of that building.

P.3 ACCEPTABLE SOLUTION

P.3.1 The requirement in paragraph P.2.1 is deemed to be satisfied if the specifications set out in paragraphs P.3.2 to P.3.3 are complied with.

P.3.2 The material used for the building work is deemed acceptable if –

- (a) the glass for the building work has a daylight reflectance not exceeding 20%
- (b) any material, other than glass and paint on plastered or concrete surfaces, for the building work on –
 - (i) the façade of the building has a specular reflectance not exceeding 10%
 - (ii) the roof of the building, inclined at an angle not exceeding 20 degrees from the horizontal plane, has a specular reflectance not exceeding 10%
 - (iii) the roof of the building, inclined at an angle more than 20 degrees from the horizontal plane, has a daylight reflectance not exceeding 20% and a specular reflectance not exceeding 10%
- (c) emulsion paint on plastered or concrete surfaces has a specular reflectance not exceeding 10%

Note 1 For the purpose of (b)(ii) and b(iii), in any building where the façade and the roof continue seamlessly, the area above the last finished floor will be considered the roof.

- 2 *Daylight reflectance is the sum of specular reflectance and diffuse reflectance.*

P.3.3 The testing of reflectance values for any material shall be conducted in accordance with ASTM E903: Standard Test Method for Solar Absorptance, Reflectance, and Transmittance of Materials Using Integrating Spheres, or equivalent, with an integrating sphere of minimum 150mm diameter.

Explanatory Notes P.3.2 – Daylight reflectance

- **Daylight reflectance** - measurement of the percentage of the visible light (i.e. wavelengths between 380nm and 780nm) reflected off the material surface. It refers to the **sum of the specular reflectance and diffuse reflectance** of the material
- **Specular reflectance** - the mirror-liked reflection of a beam of light from a surface, in which the beam from a single incoming direction is reflected into a single outgoing direction
- **Diffuse reflectance** - when light beam falls onto a rough surface, the rays of light will be reflected in different directions

Types of reflection:

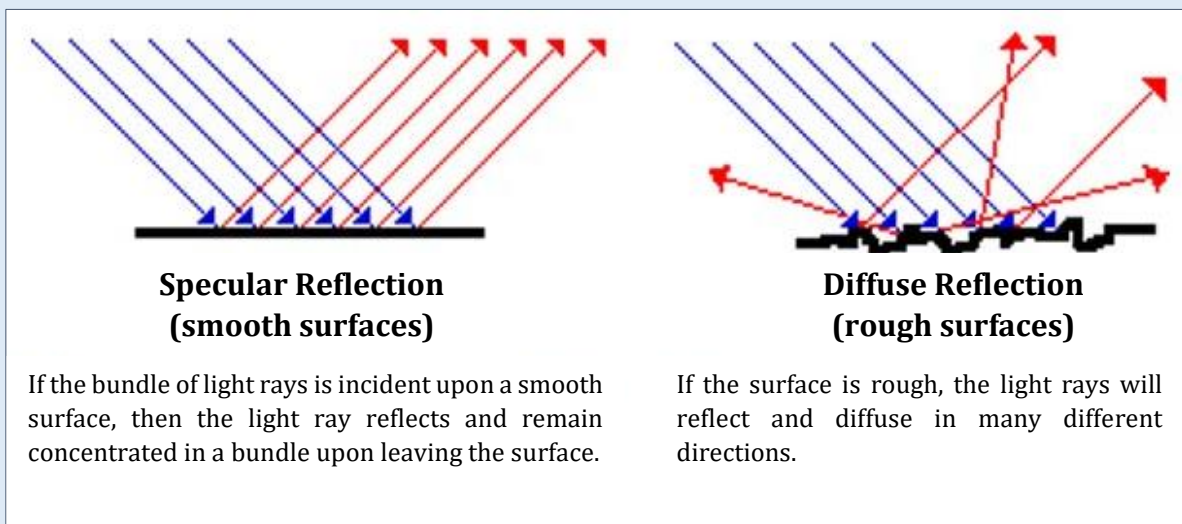

Figure P—1: Comparison of specular and diffuse reflection

Site Observations P.3.2 – Daylight reflectance

For diffuse reflectance, the angle of the pitched roofs and the close proximity of the neighbouring developments are the main reasons for causing dis-amenity (please see illustrations below). Dis- amenity is most acute when attic roofs are sloped at 45° and directly facing the neighbour’s rooms.

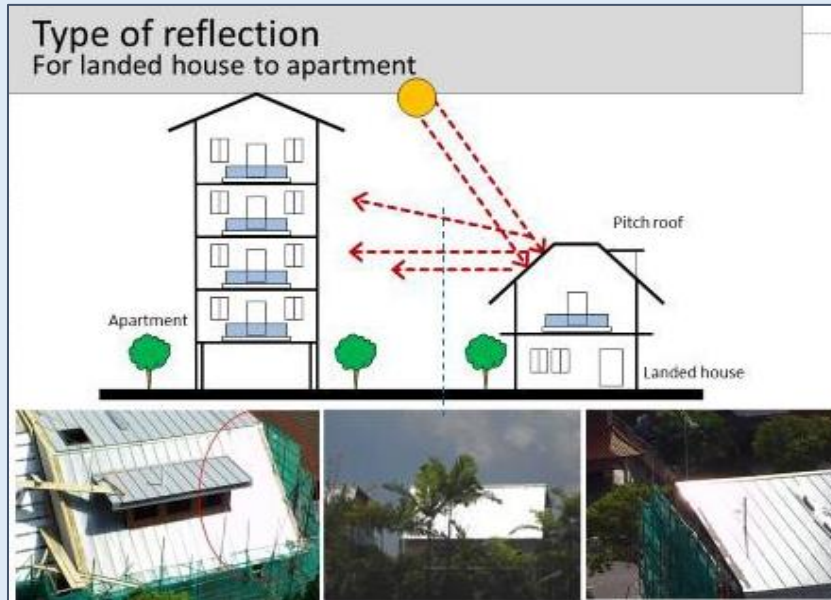

Figure P—II: Comparison of specular and diffuse reflection

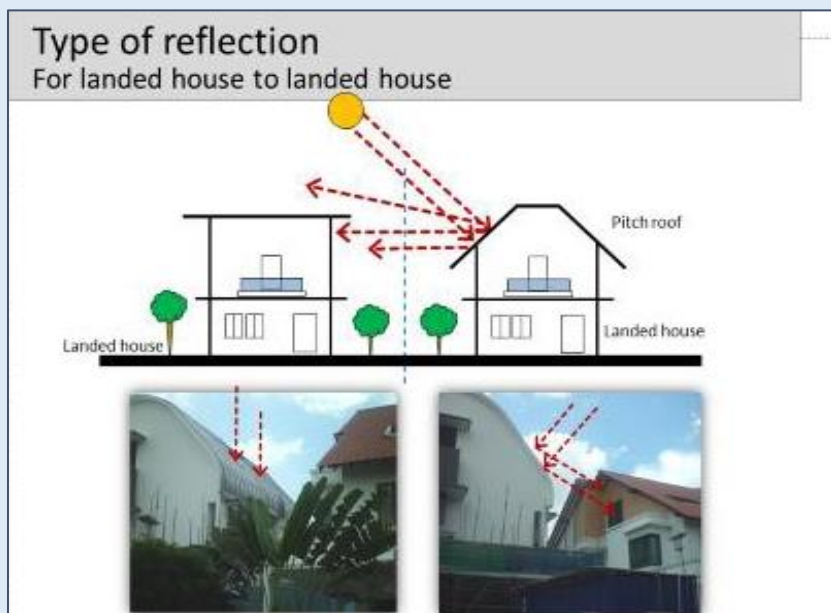

Figure P—III: Reflection from landed house to landed house

ANNEX 1 – LOFT REQUIREMENTS

The following guidelines on the need for approval of plans for lofts or intermediate floor decks shall be observed to ensure safety and the structural integrity of buildings.

The Developer/owner should engage a qualified person to check and ensure that the addition and usage of lofts or intermediate floor decks at every floor do not exceed the designed load capacity of the unit and of the entire building.

Building Control requirements regarding erection of lofts and intermediate floor deck

The loads from the loft or intermediate floor deck must be directly transferred to the floor slab on 4 supports and must not be supported on sides of walls or suspended from the ceiling slab. The support shall only be of lightweight material (timber or steel) and must not be constructed using Reinforced Concrete. If the loft or floor deck material are constructed using metal plates and/or concrete screed finishing, approvals of Building Plan and Structural Plan by the Commissioner of Building Control will be required. However, the frame supporting the loft can be lightweight joists (aluminium or steel).

Loft or intermediate floor deck with plan area of 5m² or less and constructed using timber flooring:

Building plan and Structural Plan approvals are not required for a loft or intermediate floor deck with plan area of 5m² or less and constructed using timber flooring.

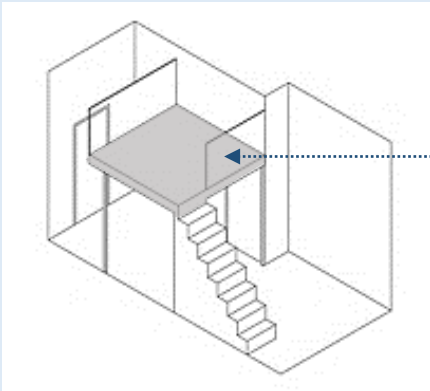

Figure A1-1: Loft diagram of plan area $\leq 5\text{m}^2$

BP and ST approvals are **not** required when

- plan area does not exceed 5m²; and
- is constructed with timber flooring/ decking

Loft or intermediate floor deck with plan area of more than 5m² or any loft with flooring other than timber decking:

For the erection of a loft or intermediate floor deck with plan area of more than 5m², or any loft with flooring other than timber decking, approvals of Building Plan and Structural Plan by the Commissioner of Building Control are required i.e., all Building Control requirements regarding structural loading, ventilation, room height, headroom, staircase and provision of safety barriers shall be complied with.

Plan submissions shall be accompanied with a no-objection letter from the Developer/MCST, and a QP's declaration that the additional loading from lofts have been catered for in the design of the building structure by the original QP (Structural).

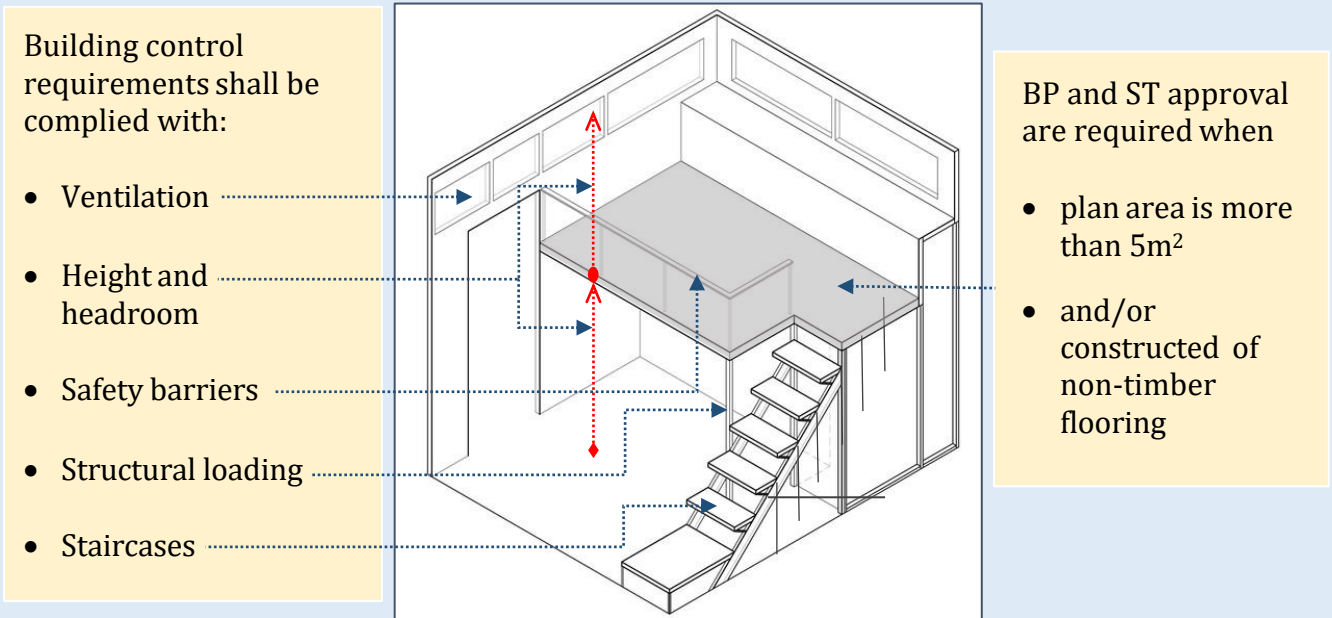

Figure A1—II: Loft diagram of plan area more than 5m²

Building control requirements shall be complied with:

- Ventilation
- Height and headroom
- Safety barriers
- Structural loading
- Staircases

BP and ST approval are required when

- plan area is more than 5m²
- and/or constructed of non-timber flooring

Making provisions for loads from loft and intermediate floor deck

Where a building is designed and constructed with high volume space to allow for the future addition of a loft or intermediate floor deck, developers should inform their consultants to cater for the additional loads to the building structure, including its foundation. For example, for a residential development with high floor-to-ceiling height that will allow the addition of loft or intermediate floor deck within the residential units, the structural design should cater for the following additional loads (over and above the normal design loads) for each floor: -

- a. a minimum imposed load of 1.5 kN/m² to allow for imposed load on the loft or intermediate floor deck; and
- b. a minimum superimposed dead load of 1.0 kN/m² to allow for the weight of the loft or intermediate floor deck.

Where a loft or intermediate floor deck is intended for usage other than residential occupancy class, the provision for additional imposed load and superimposed dead load due to the loft or intermediate floor deck should be increased accordingly.

Horizontal loading and design of glass panel barriers at loft or intermediate deck:

At the loft or intermediate floor deck, glass panels in various sizes and dimensions are often designed as barriers. As a person may lean against these glass panels, such panels shall be designed and constructed to withstand the required horizontal loading.

Computation of Loft areas

The loft area does not include the staircase and landing. A landing is the area of a floor near the top or bottom step of a stair. It is typically used to allow stairs to change directions, or to allow the user to rest. The depth and width of the landing should not exceed the width of the staircase and not at the same level as the main deck for the landing to be excluded from computation of loft area.

- i. A dropped deck before a main deck of a loft shall be computed into the loft areas. In *Figure A1-III* below, the loft area is the sum of A (main deck) **and** B (dropped deck).

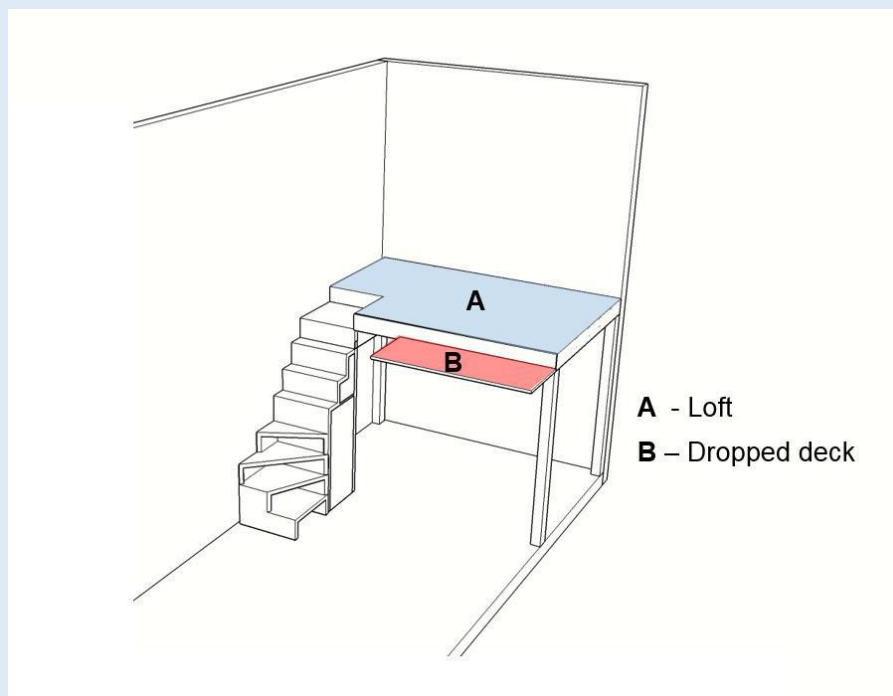

Figure A1—III: Plan view of Loft with dropped deck

- ii. The landing space at the top of the flight of stairs will not be computed as part of the loft areas if the depth and width of this landing do not exceed the width of staircase. The landing shall not be at the same level as the main deck. In *Figure A1-IV* below, the loft area comprises A (main deck) but excludes C.

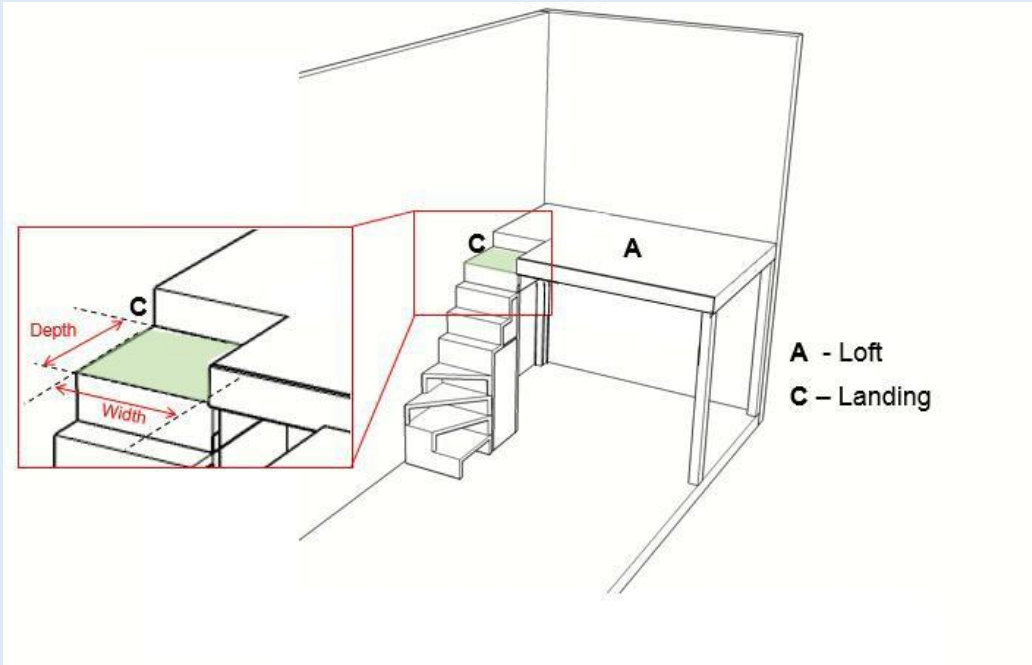

Figure A1-IV: Plan view of loft area with square landing

ANNEX 2 – MECHANISED CAR PARKING SYSTEMS

Mechanised Car Parking Systems (MCPS)

Examples of MCPS:



Figure A2—I: Example of MCPS at Changi Village

MCPS that require approval of plans and permit

MCPS that comprise supporting steel frames, with or without their own foundation system, are considered as building structures requiring approval of plans and permit under the Building Control Act.



Figure A2—II: Examples of MCPS that require approval

Requirement on safety from falling

As the MCPS consist of moveable parts, the requirements for safety from falling under the Building Control Regulations will be applicable for the following situations:

- a) If the vehicle is parked on a platform where a difference in level of 1.0 m or more exists; and
- b) If a person is required to access the platform to pick up the vehicle.

In *Figure K.3*, the drop of 1m is being rectified with safety barriers.



Figure A2—III: The risk of fall at the MCPS is being mitigated with barriers

Requirement on provision of accessible parking lots

Accessible parking lots must be provided in developments where MCPS are proposed. It shall comply with the requirements stipulated in the Code on Accessibility in the Built Environment. Where the accessible parking lots cannot be provided in the MCPS, surface car parking lots shall be provided in lieu.

Periodic structural inspection

Where the periodic structural inspection of a building is carried out, the professional engineer carrying out the inspection shall include the MCPS structure in the list of structures that he checks.

MCPS that do not require approval of plans and permit

If the MCPS comprises a stand-alone single-car platform lifting mechanism, approval of plans is not required as it is considered a lifting equipment, similar to those used in car workshops.



Figure A2—IV: MCPS which do not require approval of plans

Requirement on car lifts which convey driver/passengers

A MCPS is distinguished from a car lift in that a car lift is intended to convey vehicles together with driver and/or passengers during operation.

Vehicle Lifts carry Vehicle with Human (driver or any passengers) are regarded as a lift, and **must comply with:**

1. Code of Practice on the Installation, Operation & Maintenance of Electric Passenger and Goods Lifts – **SS550** (for Building Plans submitted on and after 1 July 2010) or **CP 2** (for Building Plans submitted on and after 1 Oct 2001).
2. Objectives and performance requirements set out in paragraph K of the Fifth Schedule of the Building Control Regulations.

ANNEX 3 – MOVABLE PANELS

Building Control requirements with regard to erection of lofts and intermediate floor deck

Under the Building Regulations, no movable or sliding panel shall be installed or permit the installation of any movable panel that is to be fixed on the exterior surface of a building or any part thereof. Such screens may be installed on the interior of the building as shown in Figure below.

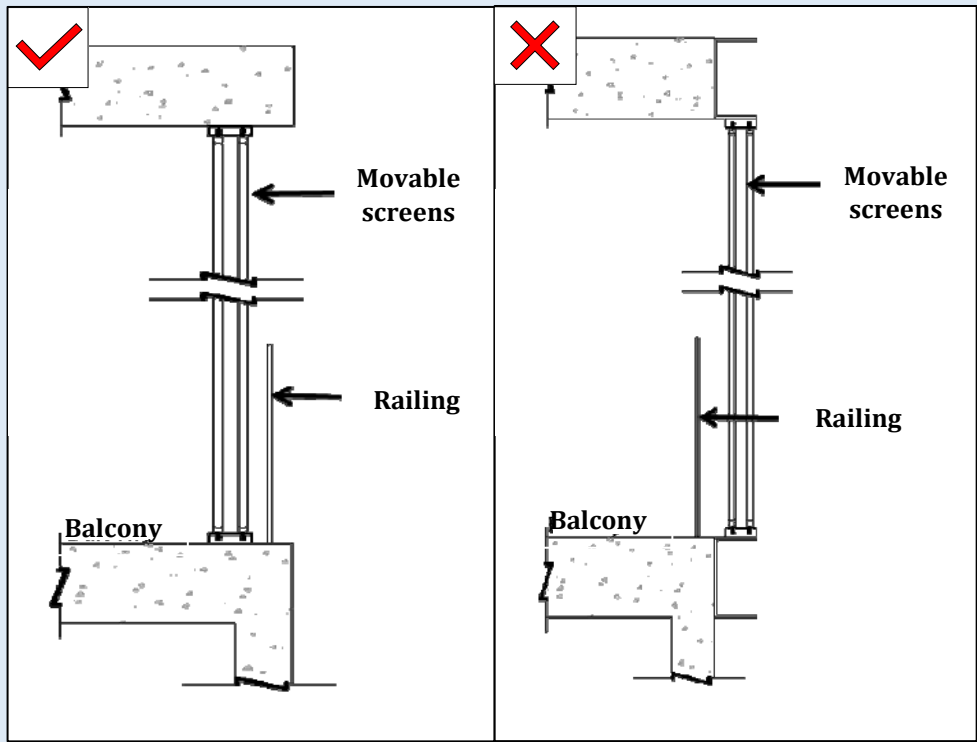

Figure A3-1: Exterior Movable Balcony Screens should be on interior of building/parapet wall

LIST OF FIGURES

FIGURE C—I: CIRCULATION SPACES AT THE UNDERSIDE OF STAIRCASES/ ESCALATORS	2
FIGURE C—II: LOW HEADROOM AT ENTRANCE IS MITIGATED BY BUILDING UP A STORAGE AREA UNDERNEATH THE STAIRCASE	3
FIGURE C—III: FUNCTION OF SPACE AT UNDERSIDE OF STAIRCASE	3
FIGURE C—IV: CHANGE OF LOCATION OF SIGNAGE TO MEET HEADROOM REQUIREMENTS	5
FIGURE C—V: STEEL STAIRCASE WAS RECTIFIED TO INCREASE HEADROOM SPACE	5
FIGURE C—VI: SLANTED STRUCTURE ALONG PASSAGEWAY WERE RECTIFIED WITH PLACEMENT OF GUARDS/ BARRIERS	6
FIGURE C—VII: SLANTED STRUCTURE AT GYM AREA WAS STRAIGHTENED	6
FIGURE C—VIII: MEASUREMENT OF HEADROOM ALONG DRIVEWAY	8
FIGURE C—IX: COMPARISON OF HEADROOM MEASUREMENTS ON THE DRIVEWAY AND CIRCULATION PATH	8
FIGURE C—X: HEADROOM NON-COMPLIANCES AT THE PARKING LOT	8
FIGURE C—XI: WINDOWS FOUND IN PRIVATE DOMAIN SPACES	9
FIGURE C—XI: HEADROOM SHORTFALL ALONG PUBLIC CIRCULATION SPACE RECTIFIED WITH PLACEMENT OF GUARDS/BARRIERS	9
FIGURE C—XII: OPENABLE WINDOWS FOUND IN PUBLIC ACCESS SPACE THAT REDUCED THE REQUIRED WIDTH OF ACCESSIBLE ROUTE	10
FIGURE C—XIII: BARRIERS AND PLANTING STRIPS ARE SOME OF THE ACCEPTABLE MEASURES FOR PUBLIC CIRCULATION SPACE	10
FIGURE C—XIV: WINDOWS FOUND IN PRIVATE DOMAIN SPACES	11
FIGURE C—XV: HEADROOM AT STAIRCASE MID-LANDING WITH PROJECTION OF LIGHT FIXTURE	12
FIGURE C—XVI: HEADROOM MEASUREMENT FROM PITCH LINE OF STAIRCASE NOSING	12
FIGURE C—XVII: EXAMPLES OF HEADROOM NON-COMPLIANCES ALONG STAIRCASES	12
FIGURE C—XVIII: DIAGRAM DEPICTING THE DIFFERENCE BETWEEN 'CEILING HEIGHT' AND 'HEADROOM' (SECTION VIEW)	13
FIGURE E—I: COMPARISON OF INCORRECT AND CORRECT MEASUREMENT OF TREAD SIZE	18
FIGURE E—II: MEASUREMENT OF TREAD WIDTH WITH ROUNDED NOSING	18
FIGURE E—III: MEASUREMENT OF TREAD WIDTH FOR A SPIRAL STAIRCASE	19
FIGURE E—IV: MEASUREMENT OF HEADROOM FOR A SPIRAL STAIRCASE	19
FIGURE E—V: EXAMPLES OF IRREGULAR RISERS	20
FIGURE E—VI: INCOMPLETE FINISHING WORK	20
FIGURE E—VII: MEASUREMENT OF THE WIDTH OF STAIRCASE WITH PROTRUDING KERB	22
FIGURE E—VIII: MEASUREMENT OF THE WIDTH OF STAIRCASE WITH PROTRUDING KERB AND HANDRAIL PROJECTING >80MM VERSUS HANDRAIL PROJECTING ≤80MM	22
FIGURE E—IX: MEASUREMENT OF WIDTH OF STAIRCASE FOR IRREGULAR LANDINGS	23
FIGURE E—X: AN EXAMPLE OF LANDING WITH A STEP BEING RECTIFIED	24

FIGURE E—XI: PHOTOS FROM SITE INSPECTIONS THAT DEPICT STAIRCASE WHICH ARE NOT PROVIDED WITH HANDRAIL	25
FIGURE E—XII: AN EXAMPLE ON THE MEASUREMENT OF HEIGHT OF HANDRAIL FROM PITCH LINE	25
FIGURE E—XIII: DIAGRAM OF ACCEPTABLE HANDRAIL PROFILES	27
FIGURE E—XIV: UNACCEPTABLE HANDRAIL PROFILE WITH SHARP CORNERS	27
FIGURE E—XV: (PHOTOGRAPH 1) UNACCEPTABLE HANDRAIL PROFILE	27
FIGURE E—XVI: (PHOTOGRAPH 2) UNACCEPTABLE HANDRAIL PROFILE	27
FIGURE E—XVII: CLEAR SPACE FROM SMOOTH WALL SURFACE (MIN. 40MM WALL GAP)	28
FIGURE E—XVIII: CLEAR SPACE FROM ROUGH WALL SURFACE (MIN. 60MM WALL GAP)	28
FIGURE E—XIX: NON-CONTINUOUS HANDRAIL DUE TO MEP FIXTURE	30
FIGURE E—XX: NON-CONTINUOUS HANDRAIL	30
FIGURE E—XXI: DIAGRAM SHOWING EXAMPLES OF HANDRAILS PROPERLY FORMED OR ROUNDED OFF	31
FIGURE E—XXII: ACCEPTABLE ROUNDED OFF HANDRAIL THAT RETURNS TO THE WALL (ONLY FOR RESIDENTIAL UNITS INCLUDING LANDED HOUSES)	31
FIGURE E—XXIII: NO NOSING PROVISION AT MAINTENANCE AREAS	33
FIGURE E—XXIV: NOSING PROVISION FOR PERFORATED METAL STAIRCASES AT MAINTENANCE AREAS	33
FIGURE E—XXV: NOSING PROVISION FOR PERFORATED METAL STAIRCASES AT MAINTENANCE AREAS	33
FIGURE E—XXVI: NOSINGS WITH POOR COLOUR CONTRAST	33
FIGURE E—XXVII: EXAMPLES OF ACCEPTABLE NOSING FINISHES	34
FIGURE E—XXVIII: UNACCEPTABLE NOSING FINISHES - ADHESIVE NOSING TAPES	34
FIGURE E—XXIX: UNACCEPTABLE NOSING FINISHES - PAINTED NOSING WEARING OFF OVERTIME	34
FIGURE G—I: WALK-IN WARDROBE ≤ 6SQM WITHOUT VENTILATION	36
FIGURE G—II: WALK-IN WARDROBE > 6SQM WITH VENTILATION	36
FIGURE G—III: WINDOW OR WALL MOUNTED FAN	38
FIGURE G—IV: DUCTED FRESH AIR SUPPLY OUTLET	38
FIGURE G—V: AN EXAMPLE OF A STANDALONE CASSETTE UNIT THAT DOES NOT CATER FOR FRESH AIR INTAKE	38
FIGURE G—VI: PRODUCTION ROOM	38
FIGURE G—VII: FROZEN CHILLER AND FREEZER ROOM	38
FIGURE G—VIII: DIAGRAM ON THE PROVISION OF NATURAL VENTILATION FOR LIFT LOBBIES OF MIXED DEVELOPMENTS	39
FIGURE G—IX: OPENINGS IN ADJUSTABLE LOUVRES	41
FIGURE G—X: OPENINGS IN FIXED LOUVRES	41
FIGURE G—XI: OPENINGS IN BALCONY	41

FIGURE G—XII: OPENINGS OF GRILLE DOORS	41
FIGURE G—XIII: CASEMENT WINDOWS WITH RESTRICTORS	41
FIGURE G—XIV: AN EXAMPLE OF ROOM WITH NO FULL-HEIGHT WALLS	42
FIGURE G—XI: ELEVATION SHOWING WINDOWS/ OPENINGS OF A ROOM	43
FIGURE G—XVI: ELEVATION SHOWING WINDOWS/ OPENINGS OF A ROOM	43
FIGURE G—XVII: CALCULATIONS OF OPENING WITH YARDS, A/C LEDGES, RC LEDGES AND RECESS AREAS	45
FIGURE G—XVIII: CALCULATIONS OF AIR WELLS AND VOIDS	45
FIGURE G—XIX: CALCULATION OF VENTILATION DISTANCE IN SECTIONAL VIEW	46
FIGURE H—I: CLIMBABLE FEATURES POSING RISK OF FALLING FROM HEIGHT	47
FIGURE H—II: LAMINATED GLASS (OUTDOOR) IN A HOUSE BUILT FOR OWNER'S OWN USE	48
FIGURE H—III: LAMINATED GLASS (INDOOR) IN A HOUSE BUILT FOR OWNER'S OWN USE	48
FIGURE H—IV: DOOR WITH PADLOCK OR A PADLOCK GATE TO A MAINTENANCE AREA	49
FIGURE H—V: STAIRCASE TO THE ROOF	49
FIGURE H—VI: ACCESSIBLE DOOR OPENING TO THE MAINTENANCE ROOF THROUGH COMMON SPACE	49
FIGURE H—VII: ONE-WAY LOCK AND SELF CLOSING DOOR / GATE WITH A SIGNAGE TO INDICATE MAINTENANCE AREA	49
FIGURE H—VIII: LOCKED-ENTRY CAT LADDER / HATCH DOORS WITH SIGNAGE TO INDICATE MAINTENANCE AREA	49
FIGURE H—IX: $\geq 1\text{M}$ WALL / NON- CLIMBABLE BARRIER/ PARAPET	49
FIGURE H—X: EXAMPLE OF A ROOF WITH SAFETY BARRIERS	50
FIGURE H—XI: ONE-WAY OR EM LOCK WITH SELF-CLOSING MECHANISM	50
FIGURE H—XII: M&E FLOOR OPENINGS WITHOUT BARRIERS	51
FIGURE H—XIII: BARRIER HEIGHT SHALL BE 1M	53
FIGURE H—XIV: EXAMPLE OF BARRIER AT LOWER EDGE OF WINDOW	53
FIGURE H—XV: EXAMPLE OF BARRIER IN A THEATRE	53
FIGURE H—XVI: EXPLANATION OF CLIMBABLE SURFACE	54
FIGURE H—XVII: EXPLANATION OF CLIMBABLE SURFACE WITH INSUFFICIENT BARRIER HEIGHT	54
FIGURE H—XVIII: EXPLANATION OF FLAT CLIMBABLE SURFACE THAT IS 1000MM AWAY FROM THE SAFETY BARRIER ALONG THE BUILDING EDGE	54
FIGURE H—XIX: EXPLANATION OF FLAT CLIMBABLE SURFACE LESS THAN 1000 MM AWAY FROM THE TOP OF THE BARRIER	54
FIGURE H—XX: $>1\text{M}$ VERTICAL DROP FROM THE KERB POSES AS A SAFETY ISSUE	55
FIGURE H—XXI: DANGER OF FALL FROM HEIGHT	55
FIGURE H—XXII: KERB ALONG CARPARK RAMP POSES DANGER OF FALLING FROM HEIGHT	55
FIGURE H—XXIII: PROVISION OF BARRIER FOR PLANTERS AT HEIGHT $<1.0\text{M}$	56
FIGURE H—XXIV: SITE OBSERVATION OF PLANTER AREAS WITH SEATINGS	56

FIGURE H—XXV: NO GAP AT 75MM FROM FFL IS APPLICABLE TO M&E AREAS	57
FIGURE H—XXVI: OPENING OR GAP SIZE IN A FLIGHT OF STAIRCASE	59
FIGURE H—XXVII: GAP SIZE BETWEEN CONSECUTIVE STEPS	59
FIGURE H—XXVIII: SECTIONAL VIEW OF GAP SIZE BETWEEN STEPS	59
FIGURE H—XXIX: CLIMBABLE TOEHOLD OF A PERFORATED BARRIER	63
FIGURE H—XXX: AN EXAMPLE OF A TOEHOLD AT A PROTRUSION > 50MM WIDTH WHICH IS AT HEIGHT LESS THAN 600MM FROM FLOOR LEVEL	63
FIGURE H—XXXI: EXPLANATION OF CLIMBABLE TOEHOLDS	64
FIGURE H—XXXII: PHOTOGRAPH OF AN INFINITY POOL	65
FIGURE H—XXXIII: SECTIONAL DIAGRAM OF INFINITY POOL WITH CATCH AREA	66
FIGURE H—XXXIV: SWIMMING POOL WITH WIDE POOL EDGE	66
FIGURE H—XXXV: AN EXAMPLE OF GLASS BARRIER WITH CONTINUOUS RAIL FIX TO TOP EDGE OF GLASS	67
FIGURE K—I: CAR LIFT INTENDED TO CONVEY VEHICLES TOGETHER WITH DRIVER/ PASSENGERS	73
FIGURE K—II: EXAMPLES OF STAIRLIFTS	77
FIGURE L—I: EXAMPLES OF OVERHEAD PROTECTION	80
FIGURE M—I: WINDOW FASTENERS	82
FIGURE M—II: SLIDING WINDOWS	85
FIGURE N1: FOUR-SIDED SSG WITH MECHANICAL SELF-WEIGHT AND RETAINING DEVICES	88
FIGURE N—II: EXAMPLE OF GLASS PANELS AT COMMERCIAL AREAS	87
FIGURE P—I: COMPARISON OF SPECULAR AND DIFFUSE REFLECTION	91
FIGURE P—II: COMPARISON OF SPECULAR AND DIFFUSE REFLECTION	92
FIGURE P—III: REFLECTION FROM LANDED HOUSE TO LANDED HOUSE	92
FIGURE A1—I: LOFT DIAGRAM OF PLAN AREA LESS THAN 5M ²	93
FIGURE A1—II: LOFT DIAGRAM OF PLAN AREA MORE THAN 5M ²	94
FIGURE A1—III: PLAN VIEW OF LOFT WITH DROPPED DECK	95
FIGURE A1—IV: PLAN VIEW OF LOFT AREA WITH SQUARE LANDING	96
FIGURE A2—I: EXAMPLE OF MCPS AT CHANGI VILLAGE	97
FIGURE A2—II: EXAMPLES OF MCPS THAT REQUIRE APPROVAL	97
FIGURE A2—III: THE RISK OF FALL AT THE MCPS IS BEING MITIGATED WITH BARRIERS	98
FIGURE A2—IV: MCPS WHICH DO NOT REQUIRE APPROVAL OF PLANS	98
FIGURE A3—I: EXTERIOR MOVABLE BALCONY SCREENS SHOULD BE ON INTERIOR OF BUILDING/ PARAPET WALL	100