

Guide on Building Information Modelling (BIM) e-Submission: Fixed Installation (FI) Requirements

Part 1: SS550 TRACTION LIFT REQUIREMENTS

Contents

ACKNOWLEDGEMENTS	3
OBJECTIVES	3
1 Submission Requirements	4
1.1 General Requirements	4
2 Core Information for BIM objects	6
3 Peripheral Components	13
Reference to requirements in SS 550 : 2020	14
SS550:2020 Figures	20

ACKNOWLEDGEMENTS

BCA would like to acknowledge the contributions of the followings organizations which had provided their valuable inputs during the development of this guide:

Chevalier Singapore Holdings Pte. Ltd.

Hitachi Elevator Asia Pte. Ltd.

ICON Engineers

KONE Pte. Ltd.

OTIS Elevator Company (Singapore) Pte. Ltd.

Schindler Lifts (Singapore) Pte. Ltd.

OBJECTIVES

The objective of this Guide is to assist Specialist Professional Engineers (SPEs) and Lift Contractors to prepare BIM model(s) for new lift installations and lifts intended to undergo major addition or replacement (A/R). As announced in 2021, the government will be launching a new co-creation platform between the public agencies and industry to transform the current regulatory landscape and practices through adoption of BIM technologies and collaborative workflows. The new system, also known as CORENET X¹ system, will replace CORENET 2.0. The new regulatory approval process under CORENET X will require the industry to collaborate and coordinate their designs upfront before submission.

For construction projects involving gross floor area (GFA) larger than 5,000m², BIM models of the projects, with key data structures related to the properties of the different entities and objects of the building needs to be included in the model. All disciplines (Architecture, Structural and MEP) will be required to submit to the authorities in BIM.

This Part of the Guide presents the minimum requirements in BIM for lifts (which are required to comply with the Singapore Standard SS550) and their components to be included in the submissions to BCA for approval.

This Guide should be read together with the other BIM guides including “Code of Practice for Building Information Modelling (BIM) e-Submission Mechanical, Electrical & Plumbing (MEP) Requirements” and “BIM Essential Guide for MEP Consultants”. Softcopies of the guides can be found [https://www.corenet.gov.sg/general/building-information-modeling-\(bim\)-e-submission.aspx](https://www.corenet.gov.sg/general/building-information-modeling-(bim)-e-submission.aspx).

BCA has also prepared generic BIM lift component family to help users in preparation of the BIM plans for e-submissions. The family components include the essential objects mentioned in Chapter

¹ CORENET X – for more information, please refer to <https://www1.bca.gov.sg/regulatory-info/building-control/corenet-x>

2 of this Guide. The family components are developed to be as ‘lightweight’ as possible and will only resemble the layout of the actual product, as it is meant to comply with code requirements. Industry is welcome to adapt and customize the BIM components to suit its own use. The family components generic models can be downloaded (at <https://www1-bca.gov.sg-admin.cwp.sg/regulatory-info/lifts-escalators/building-information-modelling-for-fixed-installation-design-plans-submission/generic-family-model-for-lift-components>) and adjusted for specific model use.

1 Submission Requirements

This guide should be read in conjunction with the **Guidebook for Plans Submission and PTO Application of Fixed Installations**. The guidebook illustrates the processes for the Fixed Installation (FI) Regulatory Regime at the various phases of the project to obtain the Permit to Operate (PTO).

New installation or major A/R of SS550 traction lifts will require plan submission. Documentations and information required under the plan submission include equipment data details, layout plans and type test reports and certificates which is spelt out in the **Guidebook for Plans Submission and PTO Application of Fixed Installations**.

When CORENET X is launched, BIM submission will be required for projects with a GFA larger than 5000m².

The **BIM e-Submission Template** to be used for BIM Regulatory Submission, as well as the **BIM e-Submission Template Guide** which explains how the Template shall be used, can be downloaded from the CORENET website: [https://www.corenet.gov.sg/general/building-information-modeling-\(bim\)-esubmission.aspx](https://www.corenet.gov.sg/general/building-information-modeling-(bim)-esubmission.aspx)

1.1 General Requirements

To prepare the industry for launch of CORENET X, the file format acceptable will be Native File Format.

Model shall be created in full size of 1:1 scale and shall be in metric units. 2D views generated from the model shall be in the same drawing scales.

File naming, color standards and other document standardization should follow the conventions as listed under the ‘Code of Practice for Building Information Modelling (BIM) e-Submission – General Requirements’: https://corenet.gov.sg/media/2157490/1_cp_for_bim_esubmission_qr_v1-1.pdf

The submissions shall comprehensively cover important aspects of the lift design described in the following sections. When in doubt, the QP may consult the Electrical and Mechanical Engineering Group of BCA for clarification.

Format	What should the file consist of?
Native BIM File Format (.rvt, .pla, .dgn)	<ol style="list-style-type: none"> 1. Location of building 2. Location of lift (or groups of lifts) in relation to the building

<p>Maximum File Size of 1GB each</p>	<ol style="list-style-type: none">3. Location of machine room (including access door dimensions and clearance spaces around machinery and control cabinets)4. Location of lift shafts5. Access path to machine room (if applicable)6. Car position at the bottom level7. Occupancy space below lift pit (e.g. underground carpark) if applicable8. Dimensions and position of ladder in hoistway and/or lift pit9. Lift components at the confirmed location<ol style="list-style-type: none">a. Traction motorb. Governorc. Lift Car and safety gearsd. Landing Doore. Bufferf. UPS/EBOPS, ARDg. Controller Box and/or Control Panelsh. Counterweighti. Guide rails
--------------------------------------	--

2 Core Information for BIM objects

This section describes the essential properties/attributes of the model objects that shall be provided for SS550 traction lift BIM submission.

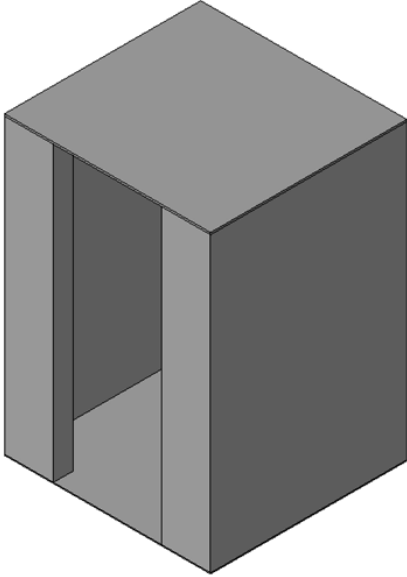
Lift Car	
	
Parameter Name	Sample Value
ClearHeight	2400mm
ClearWidth	1500mm
ClearDepth	1400mm
RatedLoad	980kg
Car_Mass	1080kg
MaxDécorWeight	200kg
CapacityPeople	13 pax
TravelHeight	25000mm
ControlDevice_OperableDistance	500mm
RopeCount	3
RatedSpeed	1.0m/s
External Height of lift car*	2900mm
Width *	1800mm
Depth*	1600mm
Lift Number	PL1
BarrierFreeAccessibility	Yes/No
Brand Name	BCA
Lift Type	Passenger Lift, Fire Lift
Model Number	BCA 980
SlungDirection	Under slung

*not MC parameter but modelling parameter only

Guiderrails

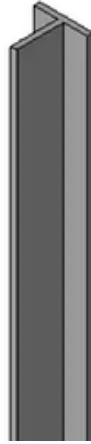

Parameter Name	Sample Value
Height*	5000mm
Width*	62mm
Depth *	89mm
Blade Width	8mm
Foot Thickness	8mm

*not MC parameter but modelling parameter only

Safety Gears

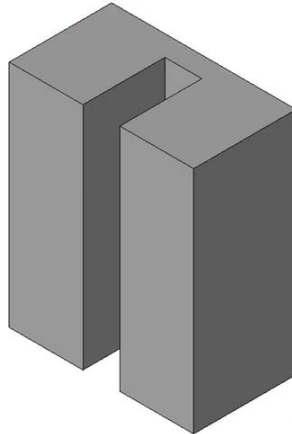

	Parameter Name	Sample Value
Intrinsic Parameter	SafetyGear_RatedSpeed	1.0m/s
Safety Gear Housing	Width*	150mm
	Length*	150mm
	Height*	200mm
Guide Rail Slot	GuideRailSlot_Width	25mm
	GuideRailSlot_Depth	140mm
Type	SafetyGearType	Instantaneous / Progressive

*not MC parameter but modelling parameter only

Car/Counterweight Buffer

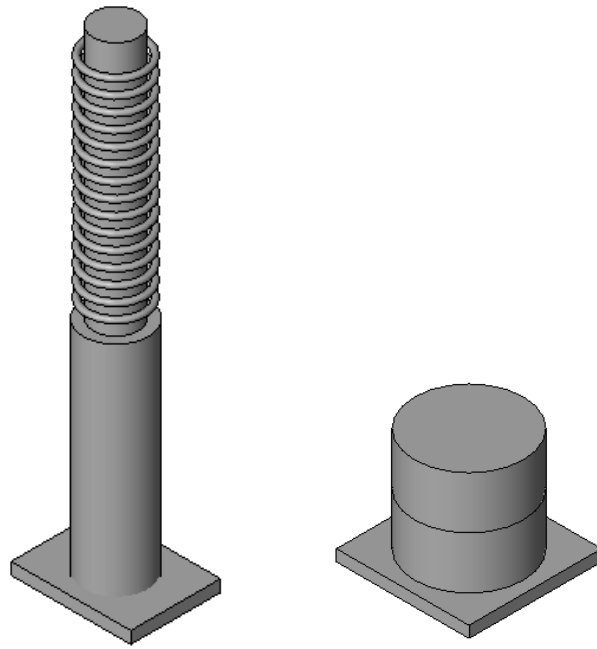

	Parameter Name	Sample Value
Intrinsic Parameters	LiftBuffer_RatedSpeed	2m/s
	LiftBuffer_Stroke	100mm
	LiftBuffer_ImpactMassRange	450kg – 3000kg
Baseplate	Width*	200mm
	Length*	200mm
	Height	20mm
Column	Diameter*	150mm
	Height	200mm
Stroke/rubber	Diameter*	100mm
	Height	175mm
Others	LiftBuffer_FixedToCar	Yes/No

*not MC parameter but modelling parameter only

Counterweight

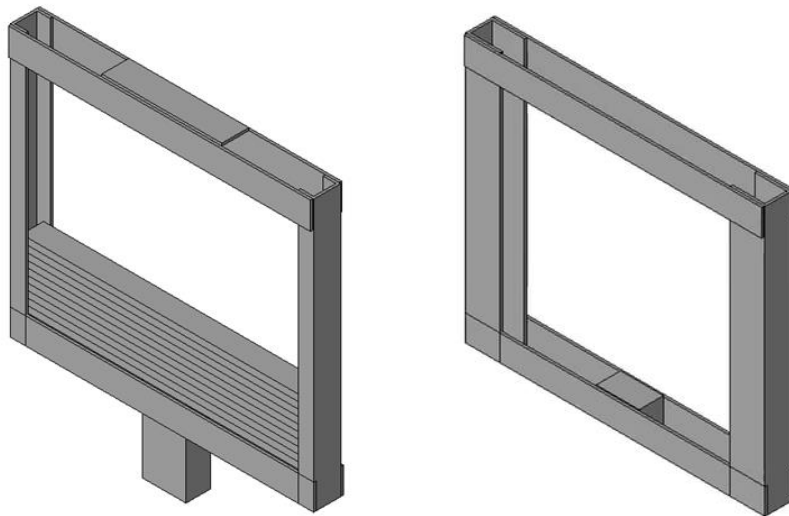

	Parameter Name	Sample Value
Intrinsic Parameter	CounterWeight_Weight	1500kg
Frame	Width*	200mm
	Length	1200mm
	Height	2000mm
Weight Plate	Width*	180mm
	Length	1180mm
	Height	150mm
Guide (Shoes)	Width*	111mm
	Length*	47mm
	Height*	78mm
Sheave	LiftSheave_Diameter	400mm

*not MC parameter but modelling parameter only

Governor

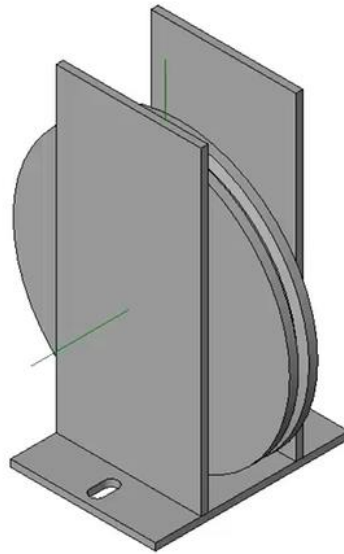

	Parameter Name	Sample Value
Intrinsic Parameter	Governor_RatedSpeed	1.5m/s
Baseplate	Width*	250mm
	Length*	320mm
	Height*	400mm
Pulley	Governor_Diameter	320mm
	Governor_GrooveAngle	15
	Governor_GrooveDepth	8mm
Type	GovernorType	Bi-Directional / Machine Room Less

*not MC parameter but modelling parameter only

Traction Machine and Brakes

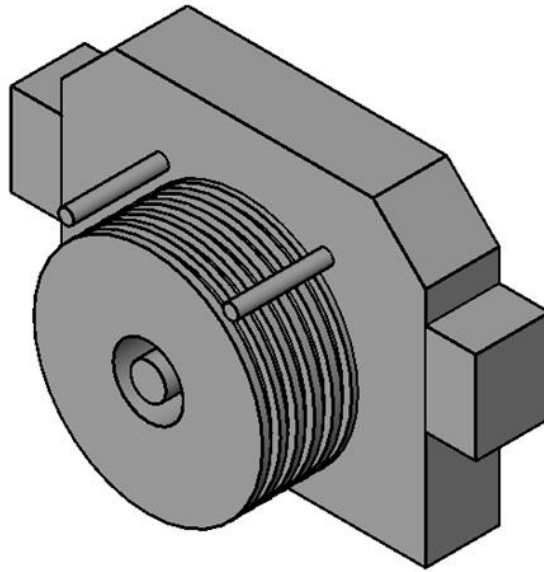

*gearless

	Parameter Name	Sample Value
Intrinsic Parameter	Machine_RatedSpeed	1.5m/s
	RopeCount	6
	RopeDiameter	10mm
	Roping	2:1
	Rope_Configuration	Single Wrap
	Rope_BreakingStrength	350N
Body	Outer Diameter*	600mm
	Inner Diameter*	400mm
	Width*	250mm
Others	DriveType	Traction
	Geared	Geared/Gearless
	BrakeType	Disc/Block/Belt
	Machine brake model	BCA DD55 Brake

*not MC parameter but modelling parameter only

Control Panel and Cabinets

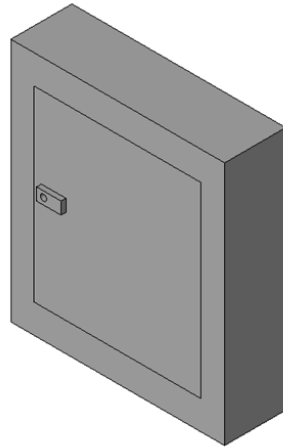

	Parameter Name	Sample Value
Body	Width*	250mm
	Length*	750mm
	Height*	950mm
Others	CabinetType	Control Panel, EBOPS/UPS, E&I Panel
If "Control panel"	Model	BCA55

*not MC parameter but modelling parameter only

Landing Door and Landing Door Lock		
	Parameter Name	Sample Value
Body	Width*	50mm
	Length*	900mm
	Height*	2100mm
Others	OperationType	Vertically sliding/Not vertically sliding,Side/Centre opening
	Number of panel(s)*	2/4/6
	DoorLockOpenableFromPit	Yes/No
	Car Door Operator Brand	BCA
	Car Door Operator Model	BCA Drive X
	Light Curtain/Photocell Brand	BCA
	Light Curtain/Photocell Model	BCA55 Y
DoorSafetyDevice	Mechanical Safety Edge/Photocell/Light Curtain	

*not MC parameter but modelling parameter only

3 Peripheral Components

Notwithstanding the above-mentioned lift components, there are also other components which are essential to lift operations. However, these are usually not proprietary items to the lift models and can usually be shown in different manners. Hence, it is still critical for the following items to be shown in the BIM model(s) for submission to BCA.

- a) Car apron
- b) Trapdoor
- c) Interior design such as handrail and kickplate
- d) Main sheave and deflection sheave
- e) Brakes (if independent from traction motor)
- f) Counterweight mesh and mesh between lifts
- g) Pit access ladder
- h) Ventilation opening in hoistway (ventilation opening in lift car is optional)
- i) Spaces around machine and control cabinets

Accessories such as limit switches, door locking devices (contactor), landing sills, hall call buttons, call light and signal need not be shown.

Reference to requirements in SS 550 : 2020

The following list of parameters extracted from *SS550:2020 Code of Practice* for traction lifts should be reflected in the BIM submissions where possible. Parameters or properties that are not reflected in the submitted layout plans and drawings will need to be declared to be of compliance to *SS550:2020* requirements.

Parameter		Requirement
Component Specific		
Lift car	a) Interior clear height of lift car	Minimum 2000mm.
	b) Dimensions of lift car platform (width x depth)	Maximum car platform area to correspond to rated loading capacity given in the table 'Rated load and maximum available car area'.
	c) Lift car rated load and passenger capacity	<i>*Fire Lifts require a minimum platform area of 1.45m² with minimum rated load of 600kg.</i>
	d) Dimensions of lift car door (height x width x thickness)	Minimum 2000mm height.
	e) Lift rated speed	-
	f) Dimensions of emergency trap door	Minimum 400mm x 500mm.
	g) Provision of protective device (e.g. light curtain)	Minimally cover distance between 25mm to 1600mm above car door sill (for horizontally sliding doors)
	h) Provision and dimensions of apron below car sill	<ul style="list-style-type: none"> • Minimum width = Full width of clear landing entrance • Minimum 750mm length
Ropes and Sheaves/Pulleys	a) Means of fixing suspension rope ends to car, counterweight and suspension points	<ul style="list-style-type: none"> • Self-tightening wedge type socket, or • Ferrule secured eyes, or • Swage terminals
	b) Number of suspension ropes	Minimum 3.
	c) Diameter of suspension ropes	<ul style="list-style-type: none"> • Minimum 8mm rope diameter.
	d) Diameter of sheaves and/or pulleys	<ul style="list-style-type: none"> • Minimum 40:1 sheave/pulley diameter to rope diameter ratio (For round steel wire ropes)
Overspeed Governor	a) Diameter of governor ropes	Minimum 30:1 pulley diameter to rope diameter ratio
	b) Pitch diameter of pulley	

Parameter		Requirement
Declaration of equipment provision	a) Provision of emergency alarm device and intercom system	-
	b) Provision and location of Automatic Rechargeable Emergency Supply (ARES)	-
Lift Landing		
Clearance Distances	a) Horizontal distance between lift car sill and lift landing sill	Maximum 35mm
	b) Horizontal distance between leading edge of lift car door and lift landing door	Maximum 120mm
Landing Door	a) Dimensions of door (height x width x thickness)	Minimum 2000mm height
	b) Material of doors	<i>*Additional requirements for doors made of glass</i>
	c) Position of unlocking triangle on landing door	<ul style="list-style-type: none"> • Vertical plane: Maximum 2000mm height above landing • Horizontal plane (facing downwards): Maximum 2700mm height above landing
Lift Shaft		
Clearance Distances (involving lift shaft walls, lift car, counterweight, and pit access ladder)	a) Clearance between lift car and lift shaft walls	<ul style="list-style-type: none"> • Minimum 20mm (except on the side used for loading/unloading for lift car) • Maximum 150mm for the side of lift car doors
	b) Clearance between counterweight and lift shaft walls	Minimum 20mm
	c) Clearance between lift car and counterweight	Minimum 50mm
	d) Position of pit access ladder with respect to lift shaft wall and lift landing entrance	<ul style="list-style-type: none"> • Minimum 200mm clearance between back of rung of ladder and lift shaft wall • Maximum distance of 600mm between middle of ladder rungs and edge of lift landing entrance

Parameter		Requirement
		<ul style="list-style-type: none"> Minimum 1500mm vertical distance between top of ladder uprights (or other suitable handhold) and landing sills
	e) Horizontal clearance between outer edge of lift car roof and lift shaft walls	For horizontal clearance >300mm: Balustrade required (dimensions in accordance to 5.4.7.4)
Compensation Means	a) Provision of compensation means	<ul style="list-style-type: none"> For lifts with rated speed < 3 m/s: Chains, ropes or belts may be used For lifts with rated speed > 3 m/s: Compensation ropes required For lifts with rated speed > 3.5 m/s: Compensation ropes and anti-rebound device required <p><i>*For lifts with rated speed > 1.75 m/s, compensation means without tensioning shall be guided at the vicinity of the loop</i></p>
	b) Diameter of compensating ropes (if applicable)	Minimum 30:1 tensioning pulley diameter to rope diameter ratio
	c) Pitch diameter of tensioning pulleys (if applicable)	
Others	a) Distance between consecutive landing doorsills lift landings	<ul style="list-style-type: none"> For distance >11m: Emergency doors of minimum 850mm width x 2000mm height must be provided) <p><i>For consecutive landing sills with distance > 18m, rescue hooks will be required in accordance with SS550:2020 Section 5.2.3.5 [Will be under SCDF requirement]</i></p>
	b) Length of guiderail	Minimally allows for additional 100mm travel from car/counterweight's highest position
	c) Position and size of vent opening	<ul style="list-style-type: none"> Topmost part of lift shaft Total unobstructed area of at least 1% of horizontal section of the lift shaft Minimum 0.1 m² for each lift in the lift shaft
Lift Pit		
Provision and location of components	a) Pit depth	-
	b) Provision of access door or ladder	<ul style="list-style-type: none"> For pit depth < 2500mm: Ladder required minimally For pit depth >2500mm: Access door required

Parameter		Requirement
	c) Stop switches	<ul style="list-style-type: none"> • For pit depth < 1600mm: <ul style="list-style-type: none"> ○ Maximum 2000mm vertical distance above pit floor ○ Minimum 400mm vertical distance above lowest landing floor ○ Maximum 750mm horizontal distance from door frame inner edge • For pit depth > 1600mm: 2 stop switches required <ul style="list-style-type: none"> ○ Top switch: Minimum 1000mm vertical distance above lowest landing floor ○ Top switch: Maximum 750mm horizontal distance from door frame inner edge ○ Bottom switch: Maximum 1200mm vertical distance above pit floor (must be operable from refuge space)
	d) Partition (required between moving parts of different lifts, if any)	<ul style="list-style-type: none"> • Minimum 2500mm between top of partition and lift pit floor • Maximum 300mm between bottom of partition and lift pit floor
Pit Access Ladder	a) Dimensions of pit access ladder	<ul style="list-style-type: none"> • Minimum 280mm width of ladder rungs • Space between ladder rungs to be between 250mm and 300mm (equally spaced)
	b) Cross-section of ladder rungs	<ul style="list-style-type: none"> • Circular or polygonal (square, or more than 4 sides) • Diameter or flat tread between 25mm to 35mm
	c) Cross-section of ladder uprights	Maximum 35mm width x 100mm depth
	d) Mechanical strength test of ladder uprights	As defined in <i>EN 131-2:2010+A1:2012, Clause 5</i> .
Buffer	a) Type of buffer	<ul style="list-style-type: none"> • Energy accumulation type buffer only allowed for lifts with rated speed < 1m/s (to be verified according to requirements in <i>EN 81-50:2014, 5.5</i>)
	b) Rated impact speed	-
	c) Total possible stroke of buffer	<ul style="list-style-type: none"> • Minimum 650mm, or twice the gravity stopping distance corresponding to 115% of the rated speed, whichever longer. • For energy dissipation type buffer: In accordance to <i>SS550: 2020, 5.8.2.2</i>
Counterweight Screen	a) Dimension and position of counterweight screen	<ul style="list-style-type: none"> • Minimum width = Width of counterweight • Top of counterweight screen to be minimally 2000mm vertical distance from the pit floor

Parameter		Requirement
		<ul style="list-style-type: none"> Bottom of counterweight screen to be at most 300mm from pit floor, or covers minimally the lowest point of the counterweight (resting on the fully compressed counterweight buffer), whichever lower.
	b) Clearance between counterweight and counterweight screen	Minimum 20mm
Machine Room (if applicable)		
Structural	a) Headroom from machine room floor	<ul style="list-style-type: none"> Minimum 2100mm at working areas (or minimum 1500mm for secondary machine room) Minimum 1800mm at other areas
	b) Difference in levels of machine room / machinery space floors	<ul style="list-style-type: none"> For level difference of > 380mm: A standard railing of minimum 1100mm height shall be provided at the edge of the higher level, and stairs/ladders shall be provided for access between levels
	c) Access ways	Minimum 500mm width (or 400mm where there are no moving parts or hot surfaces)
	d) Dimensions of machine room and maintenance doors	Minimum 1000mm width x 2000mm height
	e) Height of curb around openings for ropes	Minimum 50mm
Ship's Ladder (if applicable)	a) Angle of inclination to the horizontal	Maximum 60°
	b) Height of ladder	Maximum 4000mm
	c) Dimensions of non-slip threads	<ul style="list-style-type: none"> Minimum 430mm width x 130mm depth Maximum 305mm rise
	d) Design working load (minimum 1.5 kN)	Minimum 1.5 kN
Other General Requirements		
Access Doors	a) Access doors to pulley rooms	Minimum clear opening of 1400mm height x 600mm width
	b) Access trap doors for persons to machine and pulley rooms	<ul style="list-style-type: none"> Minimum clear passage of 800mm x 800mm Counterbalanced (?)
	c) Inspections doors	Maximum 500mm height x 500mm width

Parameter		Requirement
Machinery Spaces or Pully Rooms	a) Access to machinery spaces or pulley rooms	<ul style="list-style-type: none"> • Maximum 4000mm above level accessible by stairs • Sheltered passageway required with minimum 1000mm width and 2000mm height
	b) Dimensions of room	Minimum 1500mm clear height for movement
	c) Equipment clearance	<ul style="list-style-type: none"> • Access ways of minimum 500mm width • Minimum 500mm x 600mm area clearance for maintenance/inspection of moving parts • Minimum 300mm clear vertical distance above unprotected pulleys
Machinery and Working Space Clearances	a) Clear height dimensions	<ul style="list-style-type: none"> • Minimum 2100mm at working areas • Minimum 1800mm at other areas
	b) Horizontal clearance of machinery	<ul style="list-style-type: none"> • Minimum 700mm depth • Minimum 500mm width, or the full width of the cabinet/panel, whichever longer. • Minimum 500mm x 600mm area clearance for maintenance/inspection of moving parts
	c) Vertical clearance of machinery	<ul style="list-style-type: none"> • Minimum 500mm • Minimum 300mm for unprotected rotating parts
Other Declarations	a) Car top clearances (car position at top floor)	<ul style="list-style-type: none"> • Minimum 2 refuge spaces on car top when lift car is at its highest position • Allowable types of refuge spaces as shown in '<i>Dimensions of refuge space in headroom (Table 3)</i>'
	b) Car bottom clearances (car position at bottom floor)	<ul style="list-style-type: none"> • Minimum 2 refuge spaces in lift pit when lift car is at its lowest position • Allowable types of refuge spaces as shown in the table '<i>Dimension in refuge spaces in the pit (Table 4)</i>'

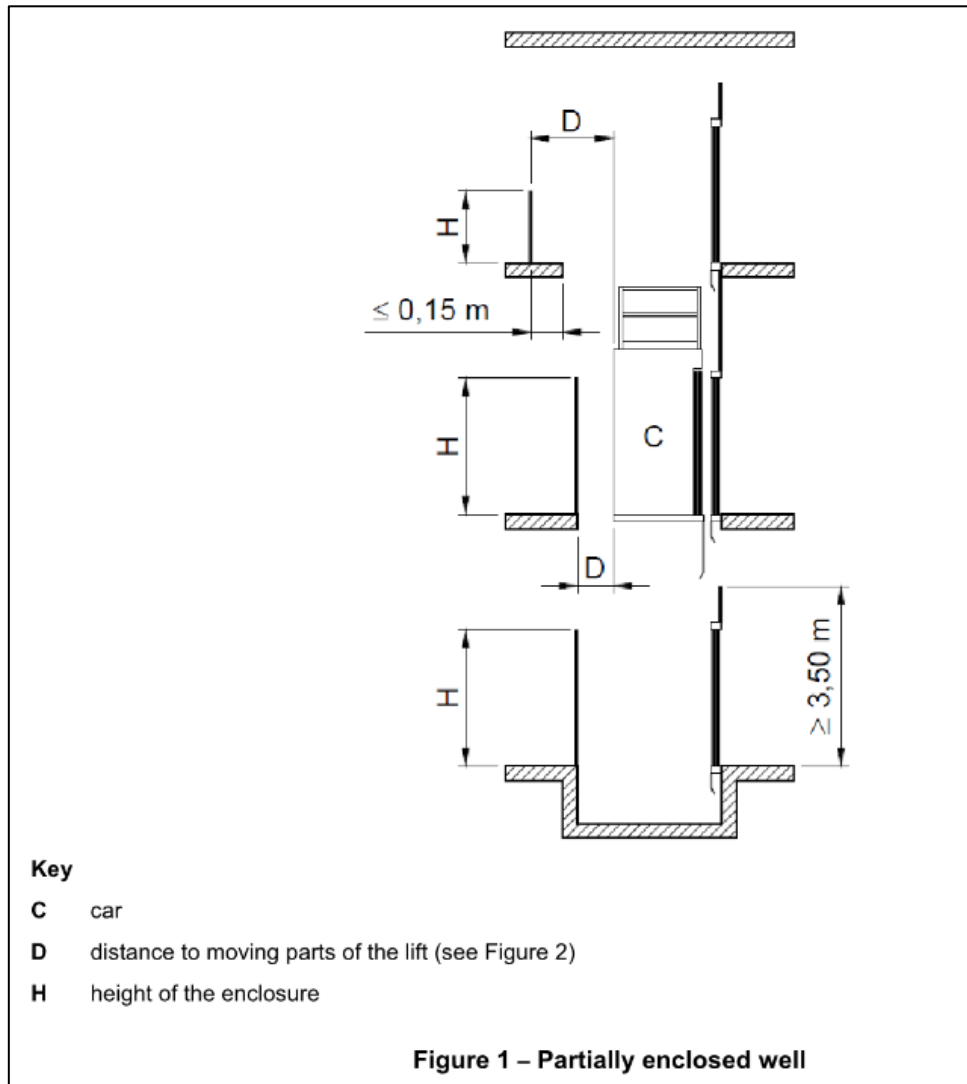

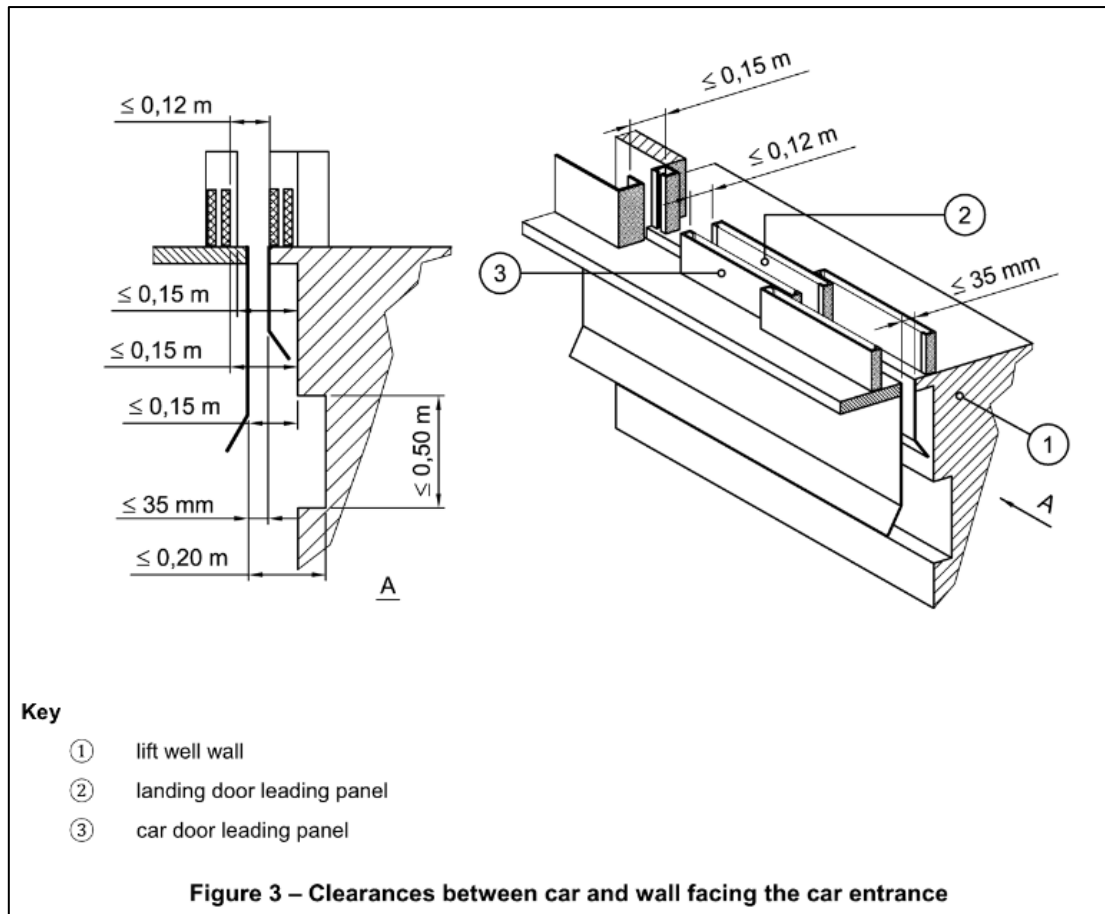





Table 3 – Dimensions of refuge spaces in headroom

Type	Posture	Pictogram	Horizontal dimensions of the refuge space (m x m)	Height of the refuge space (m)
1	Upright		0,40 x 0,50	2,00
2	Crouching		0,50 x 0,70	1,00

Key for pictograms

- ① black colour
- ② yellow colour
- ③ black colour

Table 4 – Dimensions of refuge spaces in the pit

Type	Posture	Pictogram	Horizontal dimensions of the refuge space (m x m)	Height of the refuge space (m)
1	Upright		0,40 x 0,50	2,00
2	Crouching		0,50 x 0,70	1,00
3	Laying		0,70 x 1,00	0,50
Key for pictograms ① black colour ② yellow colour ③ black colour				

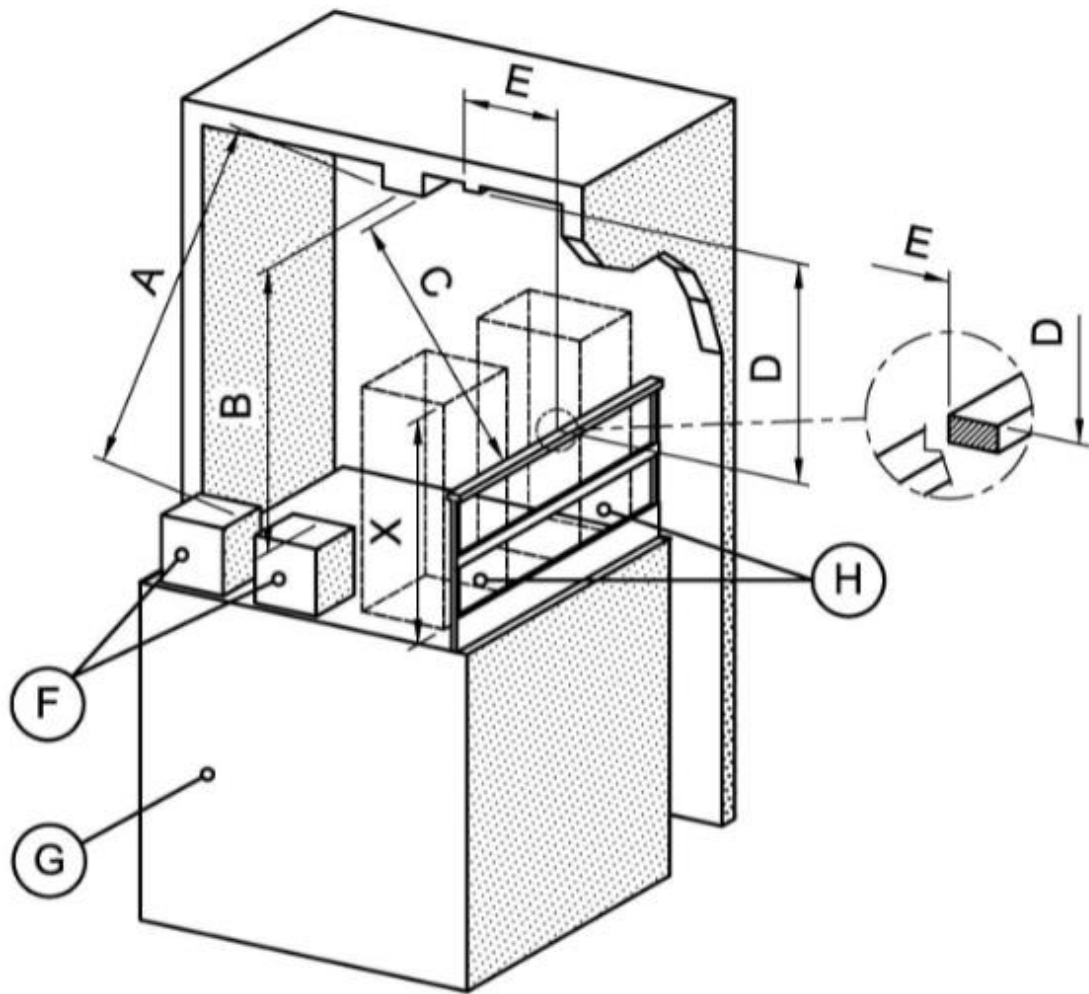

Key

- | | | | |
|---|---|---|---|
| A | distance $\geq 0,50$ m (5.2.5.7.2 a) | F | highest parts installed on the car roof |
| B | distance $\geq 0,50$ m (5.2.5.7.2 a) | G | car |
| C | distance $\geq 0,50$ m (5.2.5.7.2 c) 2) | H | refuge space(s) |
| D | distance $\geq 0,30$ m (5.2.5.7.2 c) 1) | X | height of refuge spaces (Table 3) |
| E | distance $\leq 0,40$ m (5.2.5.7.2 c) 1) | | |

Figure 5 – Minimum distances between parts fixed on car roof and lowest parts fixed to ceiling of well