

CODE ON
ACCESSIBILITY
IN THE BUILT ENVIRONMENT 2013



*The Code on Accessibility in the Built Environment 2013
is electronically published by the Building and Construction Authority.*

© Building and Construction Authority

*Issued in August 2013
Updated in October 2013*

Building and Construction  Authority

Visit our friendly built environment portal at <http://www.friendlybuildings.sg>

CONTENTS

	Preface	viii
	Chapter 1: Accessibility In The Built Environment	
1.1	Scope	1
1.2	Definitions	2
	Chapter 2: Provisions For Accessibility	
2.1	Accessibility in the Built Environment	5
2.2	Residential Development	11
2.3	Minimum Accessible Provisions	12
2.4	Inter-connectivity	15
2.5	Exemptions	16
2.6	Additions and Alteration Works	16
	Chapter 3: Arriving At The Building	
3.1	Access to Buildings	17
3.2	Approach to Buildings	18
3.3	Passenger Alighting and Boarding Points	18
3.4	Taxi Shelters	20
3.5	Accessible Vehicle Parking	22
3.6	Kerb Ramps	27
3.7	Pedestrian Crossing	31
	Chapter 4: Accessibility Around And Within The Building	
	Horizontal Circulation	
4.1	Floor and Ground Surfaces	33
4.2	Accessible routes, corridors and paths	35
4.3	Headroom	44
4.4	Doors	45
	Vertical Circulation	
4.5	Changes in Levels	58
4.6	Ramps	60
4.7	Handrails and Grab bars	69
4.8	Passenger Lifts	72
4.9	Lifts Designated for Wheelchair Users	75
4.10	Platform Lifts and Wheelchair Stairlifts	78
4.11	Stairs	80
4.12	Stairs for Ambulant Disabled	86
	Chapter 5: Sanitary Provision	
5.1	General	87
5.2	Accessible Individual Washrooms	90

5.3	Accessible Water Closet Compartments	94
5.4	Water Closet Compartments for Ambulant Disabled	98
5.5	Urinals for Ambulant Disabled	102
5.6	Components in the Accessible Washroom	103
5.7	Bath Facilities	114
5.8	Wheelchair transfer	123
Chapter 6: Usage Of Space, Facilities And Elements Within The Building		
6.1	Illumination	126
6.2	Controls and Operating Mechanisms	127
6.3	Seating Spaces	131
6.4	Service and Information Counters	133
6.5	Drinking Fountains	135
6.6	Public Telephones	136
6.7	Eating Spaces	138
6.8	Hearing Enhancement Systems	142
6.9	Family-Friendly Facilities	143
6.10	Accessible Rooms, Guestrooms and Serviced Apartments	145
Chapter 7: Residential Development		
7.1	General Requirements	148
7.2	Entrances to Units	148
7.3	Bathrooms for future retrofitting	151
7.4	Switches and Socket Outlets	154
Chapter 8: Anthropometrics And Signage		
8.1	Anthropometrics and Space Allowances	155
8.2	International Symbol of Access for Persons with Disabilities	163
8.3	Directional Signs	166
8.4	Service Identification Signs	167
8.5	Signage	167
Appendix A: Design Guidelines for Family-Friendly Facilities		
A.1	Application	175
A.2	Recommended Facilities	175
A.3	Design Considerations	176
Appendix B: Design Guidelines for Older Persons		
B.1	Ageing and Safety	188
B.2	Falls in Home	188
B.3	Advantages of Considerate Design	189
B.4	Mobility	190
B.5	Prevention of Falls	190
B.6	Design Consideration	193
B.7	Top Ten Design Points	195

Appendix C: Design Guidelines for Children With Disabilities		
C.1	Application	198
C.2	Interpretation	198
C.3	Handrails and Grab bars	199
C.4	Seating Spaces	199
C.5	Drinking Fountains	200
C.6	Sanitary Provisions	200
C.7	Children’s Reach Ranges	202
C.8	Lifts	203
C.9	Public Telephones	203
C.10	Canteens	203
C.11	Computer Rooms	203
C.12	Libraries	204
Appendix D: Design Guidelines for Persons With Visual Impairment		
D.1	Introduction	205
D.2	Visual Contrast in Building Interiors	206
D.3	Detectable Warning Surfaces	210
D.4	Application of Tactile Ground Surface Indicators	217
Appendix E: Design Guidelines for Parks And Open Spaces		
E.1	Graduated Difficulty of Access	223
E.2	Outdoor Recreation Access Routes	223
E.3	Viewing Areas	226
E.4	Outdoor Steps	228
E.5	Outdoor Facilities	230
E.6	Signage	234
Appendix F: Slip Resistance Of Floor Finishes		
F.1	Grading of Slip Resistance	237
Appendix G: Keypad Design Requirements		
G.1	General	239
G.2	Keypads Used Inside Lift Cars	239
G.3	Keypad Design	239
G.4	Registration of Calls	240
G.5	Notices	240

List Of Figures

Figure 1	Passenger Alighting and Board Point
Figure 2	Taxi Shelter
Figure 3	Angled Parking for Accessible Lots
Figure 4	Parallel Parking for Accessible Lots
Figure 5	Access Levels
Figure 6	Directional Sign
Figure 7	Examples of Signage at Accessible Parking Lot
Figure 8	Kerb Ramps with Flared Sides
Figure 9	Kerb Ramps with Returned/Continuous Kerbs
Figure 10	Kerb Ramps with Built-Up/Extended Kerbs
Figure 11	Kerb Ramps Location at Pedestrian Crossings
Figure 12	Kerb Ramps Location on Island
Figure 13	Gratings
Figure 14	Dimension and Space Requirements for Accessible Corridors
Figure 15	Width of Accessible Checkout Lane
Figure 16	Access beside Turnstiles
Figure 17	Trailing Bar
Figure 18	Limits of Protruding Objects
Figure 19	Freestanding Objects Mounted on Posts
Figure 20	Resting Areas
Figure 21	Overhead Hazard
Figure 22	Clear Width of Doorways
Figure 23	Markings on Glass Doors
Figure 24	Minimum Doorway Manoeuvring Space
Figure 25	Minimum Doorway Manoeuvring Space for 2-way Swing Door
Figure 26	Minimum Doorway Manoeuvring Space at Leading Edge of Door Leaf
Figure 27	Manoeuvring Space at Doors in a Series
Figure 28	Examples of Handles
Figure 29	Door Opening Force
Figure 30	Vision Panels and Kickplates
Figure 31	Guardrails at Out-Swinging Automatic Doors
Figure 32	Contrasted Colour, Coloured Bands or Detectable Warning Surfaces on Ramps
Figure 33	Ramps
Figure 34	Level Landings and Edge Protection
Figure 35	Ramps and Landings
Figure 36	Handrail Extensions
Figure 37	Sectional View of Edge Protections
Figure 38	Handrails
Figure 39	Braille and Tactile Markings on Lift Control Panels
Figure 40	Grab bars in Lift Cars
Figure 41	Lift for Wheelchair User
Figure 42	Example of Platform Lift
Figure 43	Example of Wheelchair Stairlift
Figure 44	Staircase

Figure 45	Handrail Extensions
Figure 46	Stair Detail
Figure 47	Example of Accessible Toilets in School
Figure 48	Detail of Accessible Individual Washroom
Figure 49	Location of Jumbo Toilet Roll Dispenser
Figure 50	Accessible Water Closet Compartment within a Toilet Cluster
Figure 51	Accessible Water Closet Compartment
Figure 52	Water Closet Compartments for Ambulant Disabled
Figure 53	Urinal for Ambulant Disabled
Figure 54	Washroom Accessories
Figure 55	Wash Basin for Person with Disabilities
Figure 56	Water Closets
Figure 57	Bathtub for Persons with Disabilities
Figure 58	Alternative Layout Plan for Bathroom for Persons with Disabilities
Figure 59	Roll-in Shower Stall for Wheelchair Users
Figure 60	Example of Accessible Individual Washroom Layout with Shower Facility
Figure 61	Wheelchair Transfers: Diagonal Approach
Figure 62	Wheelchair Transfers: Side Approach
Figure 63	Wheelchair Transfers: Frontal Approach
Figure 64	Controls and Operating Mechanisms
Figure 65	Examples of Tap Controls
Figure 66	Wheelchair Spaces in Audience Seating
Figure 67	Approach to Tables or Counters
Figure 68	Service and Information Counters
Figure 69	Built-in Drinking Fountains
Figure 70	Telephone Booth
Figure 71	Seating Arrangements
Figure 72	Table Dimensions
Figure 73	Symbols of Access for People with Hearing Loss
Figure 74	Family Car Parking Lot
Figure 75	Example of Accessible Rooms in Hotels
Figure 76	Residential Unit: Minimum Doorway Width and Manoeuvring Space at Entrance
Figure 77	Residential Unit: Corridors and Entrances
Figure 78	Residential Unit: Ramp at Entrance
Figure 79	Residential Unit: Width of Doorway at Right Angle to Corridor
Figure 80	Wheelchair Space Allowances: Minimum Clear Floor Space
Figure 81	Wheelchair Space Allowances: Minimum Clear Turning Space
Figure 82	Wheelchair Space Allowances: Typical Dimensions of Wheelchairs Commonly Used by Adults
Figure 83	Reach Ranges: Forward Reach Without Obstruction
Figure 84	Reach Ranges: Forward Reach Over Obstruction
Figure 85	Reach Ranges: Side Reach Without Obstruction
Figure 86	Reach Ranges: Side Reach Over Obstruction
Figure 87	Positions Taken by Wheelchairs when Negotiating Doors in Passageways
Figure 88	Comfortable Walking Widths

Figure 89	Symbol of Access for Persons with Disabilities
Figure 90	Example of Symbols for Persons with Different Needs
Figure 91	Directional Sign
Figure 92	Directional Signs to Facility
Figure 93	Service Identification Signs at Destinations
Figure 94	Location of Door Signs on the Latch Side of Doors
Figure 95	Recommended Specifications for Braille on Signage
Figure 96	Examples of Raised Tactile and Braille Signs
Figure A1	Water Closet for Young Children
Figure A2	Urinal for Young Children
Figure A3	Wash Basin for Young Children
Figure A4	Example of Flat Child Protection Seat
Figure A5	Child Protection Seat in Water Closet Compartment
Figure A6	Child Protection Seat and Diaper Changing Station in Accessible Individual Washroom
Figure A7	Example of Flap Diaper Changing Station
Figure A8	Example of Accessible Family Washroom with Child WC, Child Protection Seat and Diaper Changing Station
Figure A9	Example of Lactation Room
Figure A10	Example of Lactation Room at Workplace
Figure A11	Lockers for Baby Carriages
Figure B1	Examples of Rollator, Electric Wheelchair and Motorised Scooter
Figure B2	Layout of House Suitable for the Aged
Figure C1	Urinal for Children
Figure D1	Effective Luminance Contrast
Figure D2	The Hue Circle
Figure D3	Effective Hue Contrast
Figure D4	Saturation Contrast
Figure D5	Warning Indicators
Figure D6	Directional Warning Indicators
Figure D7	Application of Tactile Ground Surface Indicators at Pedestrian Crossings and Kerb Ramps
Figure D8	Application of Tactile Ground Surface Indicators at Stairs, Steps, Escalators and Passenger Conveyors
Figure D9	Application of Tactile Ground Surface Indicators at Flush Pedestrian Vehicular Way
Figure D10	Tactile Guidance Strips
Figure E1	Interconnected Facilities
Figure E2	Resting Area
Figure E3	Edge Protection for Access Route
Figure E4	Clear Ground Space
Figure E5	Unobstructed View
Figure E6	Landings
Figure E7	Outdoor Rinsing Showers
Figure E8	Telescope
Figure E9	Information Board

Figure E10 Directional Sign
 Figure G1 Keypad Buttons

List Of Tables

Table 1	Accessibility for Person with Disabilities and Families with Young Children
Table 2	Accessible Parking Lots
Table 3	Accessible Route Widths
Table 4	Changes in Levels
Table 5	Gradient and length of ramps
Table 6	Minimum Clear Width of Door Openings for Residential Units
Table 7	Height of Letters
Table 8	Sizes of Symbols
Table 9	Colour Contrast
Table 10	Recommended Specifications for Braille on Signage
Table C1	Grab Bar Height
Table C2	Water Closet Centre Lines
Table C3	Toilet Seat Heights
Table C4	Forward Reach
Table C5	Side Reach
Table E1	Risers and Treads
Table E2	Outdoor Constructed Features
Table F1	Slip Resistance of Typical Flooring Surfaces

PREFACE

1 The Code on Accessibility (the “Code”) has been an important driver behind the observable improvements to the accessibility in Singapore. Since its inception in 1990, the Code has undergone a series of periodic reviews to ensure that its provisions are comparable to international standards and, more importantly, meet the evolving needs of our local communities.

2 The fourth review of the Code began in 2010 with the formation of the Code Review Committee (“Committee”). Led by Building and Construction Authority (BCA), the tripartite committee consists of representatives from the public and private sectors. To obtain a well-rounded perspective, the Committee also consulted other stakeholders such as government agencies, voluntary welfare organisations, industry players and interest groups that were not represented in the Committee. Prior to the publication of the revised Code, the draft was circulated and posted on the BCA website for the general public to give their feedback. The Committee received many constructive comments in the course of the broad consultation process and relevant suggestions were incorporated before the Code was finalised.

3 In the latest revision to the Code, the needs of persons with disabilities remain the primary focus. More mandatory requirements are introduced to minimise restrictions in the environment, so persons with disabilities are able to make full use of the building premises and amenities. For example, to facilitate persons with hearing difficulties in participating in discussions and public performances, the provision of hearing enhancement systems will be a mandatory requirement in places such as auditoriums, concert halls and theatres. To aid persons with visual impairments in finding their way, the Code requires the use of Braille and tactile information in signs at strategic locations in buildings such as staircases and public toilets.

4 As Singapore prepares for a fast ageing population and builds an inclusive society, the Code is placing greater emphasis on universal design concepts and provisions that will benefit a wider spectrum of people, including parents with infants, the young and older persons. The Code contains new requirements for more accessible routes, corridors and paths to cater to the growing number of older persons with limited mobility, and wheelchair users. The Code also requires buildings frequented by families to provide family-friendly facilities such as child-friendly toilets and lactation rooms for nursing mothers.

5 The structure of the Code document has been re-organised for easy reference and to improve clarity. The objective for every chapter is clearly stated to aid understanding of the rationale behind the various requirements. Diagrams are refined and additional illustrations are added to minimise ambiguities in interpretation of the requirements.

6 The Code sets out the essential requirements and guidelines for making the built environment accessible and usable to persons with disabilities and families with young children. It does not give recommendations for fire safety features within buildings to facilitate the evacuation

of persons with disabilities that are already covered under the Code of Practice for Fire Precautions in Buildings.

7 The requirements in this Code should be taken into consideration at the start of the planning and design processes of a project so that accessible and family-friendly features are suitably integrated into the development. Typically, additional costs of providing for accessibility are incurred if the requirements are not provided for in the design from the onset, and alterations are needed during or near the construction stage to comply with the Code. For existing buildings, routine maintenance or refurbishment work provides opportunities for accessible features to be incorporated in a cost effective manner.

8 The progressive improvement and provision of accessible facilities are instrumental in fostering an inclusive society where people of all ages and abilities can lead active and quality lives. With a more comprehensive and balanced set of accessibility provisions, the revised Code would better address the future needs of persons with disabilities and various interest groups. It is an indication of our continual efforts to create an inclusive built environment and strive towards fulfilling our nation's obligations under the United Nations Convention on the Rights of Persons with Disabilities.

9 The Building and Construction Authority would like to extend its appreciation to the members of the Code Review Committee, the industry and the public for contributing their invaluable efforts, time and inputs towards the review and development of this Code.

**UNIVERSAL DESIGN DEPARTMENT
BUILDING PLAN AND MANAGEMENT GROUP
BUILDING AND CONSTRUCTION AUTHORITY**

CHAPTER 1

ACCESSIBILITY IN THE BUILT ENVIRONMENT

- Scope CI 1.1
- Definitions CI 1.2

1.1	SCOPE	Requirement and guidelines for accessibility
1.1.1	The aim of this Code is to set out the fundamental design and construction requirements and guidelines for making those buildings specified in Table 1 of Chapter 2 accessible to persons with disabilities and families with young children.	
1.1.2	Where buildings are required to be designed for family-friendly environments where families with infants and young children are likely to congregate, the "Design Guidelines for Family-Friendly Facilities" in Appendix A are recommended for adoption.	
1.1.3	Where buildings are required to be designed or retrofitted to provide accessibility and safety to future older and infirm populations, it is recommended that the "Design Guidelines for Older Persons" in Appendix B are adopted.	
1.1.4	The requirements and guidelines in this Code are intended to apply to adult persons with disabilities. Where a building is required to be designed or retrofitted to accommodate children with disabilities, it is recommended that the "Design Guidelines for Children with Disabilities" in Appendix C are adopted.	
1.1.5	Where a physical environment is needed to meet the needs of persons with visual impairment, it is recommended that the "Design Guidelines for Persons with Visual Impairment" in Appendix D are adopted.	
1.1.6	In addition to the requirements specified in the Code, landscape designers are encouraged to adopt the "Design Guidelines for Parks and Open Spaces" as indicated in Appendix E for Parks and Open Spaces.	
1.1.7	The requirements specified in the Code, relevant to the use of wheelchairs, are based on the dimensions of commonly used wheelchair sizes and users. For larger wheelchairs and motorised scooters, additional space allowances will have to be considered according to the needs of the intended users.	

1.1.8 Persons with severe physical disabilities may have requirements beyond the standards provided in this Code.

1.2 DEFINITIONS

Definitions

1.2.1 For the purpose of this Code, the definitions below shall apply:

“accessible” describes a site, building, facility, pedestrian path and interconnection that complies with this Code and that can be approached, entered and used by persons with disabilities, older persons and other intended users as specified in this Code;

“accessible route” is a continuous unobstructed path connecting all accessible elements and spaces in a building or facility that can be negotiated safely by persons with disabilities. This accessible path shall not incorporate any step, drop, stairway, turnstile, revolving door, escalator or other impediment which would prevent it from being safely negotiated. Interior accessible routes shall include doorways, corridors, floors, ramps, lifts and clear floor spaces at fixtures. Exterior accessible routes shall include parking access aisles, kerb ramps, walkways and ramps;

“access route plan” is a plan showing the barrier-free access to the building from adjacent buildings and nearest public facilities as well as barrier-free access within the building;

“ambulant disabled” is a person who is able, either with or without personal assistance, and who may depend on prostheses (artificial limbs), orthoses (callipers), sticks, crutches or walking aids to walk or negotiate suitably graded steps with convenient handrails;

“building” shall include part of a building;

“circulation path” is an exterior or interior way of passage from one place to another for pedestrians including walkways, hallways, courtyards, doorways, stairways and stair landings;

“detectable warning surface” is a surface feature of contrasting colour, tone and texture, built in or applied to walking surfaces or other elements to alert persons with visual impairment of hazards on a circulation path;

“family washroom” is a public, unisex washroom that is available for use by an individual and an accompanying child, family member or caregiver of the same or opposite sex;

“grab bar” is a bar used to maintain balance and to give steadying, stabilising assistance or support in locations such as bathrooms, toilets and lifts;

“guide dog” is a specially bred and extensively trained service animal that guides a blind or visually impaired person;

“handrail” is a rail used to give stability and support in circulation areas such as corridors, passageways, ramps and stairways to assist in continuous movement;

“individual washroom” is a compartment having the basic requirements of a water closet compartment, wash basin and other essential washroom accessories as required by persons with disabilities;

“kerb” is a side barrier to a road or pavement;

“kerb ramp” is a short ramp cutting through a kerb or built up to it;

“operable part” is part of a piece of equipment or appliance used to insert or withdraw objects or to activate, deactivate, or adjust the equipment or appliance (for example, coin slot, push-button, handle);

“persons with disabilities” are persons whose mobility and use of a building are affected as a consequence of one or more of the following physical or sensory disabilities or impairments:

- (a) mobility impairment;
- (b) mobility impairment which requires the use of wheelchair;
- (c) hearing impairment or deafness; or
- (d) visual impairment or blindness;

“place of public resort” means a building or a defined or enclosed place used either as a church, chapel, mosque, temple or other place where public worship is or religious ceremonies are performed, or as a community club, country club, cinema, theatre, public exhibition / concert / lecture hall, public ballroom, museum, stadium or a public place of assembly for persons admitted thereto by tickets;

“primary access route” is the main access route used by the occupants or visitors from the road to the main entrance and the key functional or activity areas of the place or building;

“ramp” is an inclined way connecting one level to another;

“secondary access route” is an access route provided in addition to the primary access route and caters to a lower volume of human traffic;

“symbol” means the International symbol of access for persons with disabilities;

“water closet compartment” is a compartment having a water closet with grab bars installed to assist persons with disabilities;

“wheelchair user” is a person who depends on a wheelchair for mobility;

“width” is the clear distance from one finished surface to another;

“white cane” is a mobility aid to guide persons who are visually impaired, and to detect obstructions as they move in the environment.

1.2.2 Unless otherwise specified, all dimensions shown in the figures in this Code are in millimetres (mm).

1.2.3 Where “shall” is used in this Code, it refers to mandatory design requirements and where “should” is used, it refers to recommended design requirements.

1.2.4 Unless the context otherwise requires:

- (a) words importing the singular shall include the plural and vice versa;
and
- (b) words importing the masculine gender shall include the feminine gender and vice versa.

CHAPTER 2

PROVISIONS FOR ACCESSIBILITY

- Accessibility in the Built Environment CI 2.1
- Residential Development CI 2.2
- Minimum Accessible Provisions CI 2.3
- Inter-connectivity CI 2.4
- Exemptions CI 2.5
- Additions and Alterations Works CI 2.6

2.1 ACCESSIBILITY IN THE BUILT ENVIRONMENT

Application of accessibility in the built environment

2.1.1 The areas or levels in the types of buildings specified in Table 1 shall be made accessible for persons with disabilities and other intended users in accordance with the provisions of this Code.

2.1.2 Where a site, building, facility, room, or space contains more than one use, each portion shall comply with the applicable requirements for that use.

TABLE 1

Accessibility for Persons with Disabilities and Families with Young Children

Building Type	Accessible Areas	Key provisions to note**	
		Sanitary provision	Other provisions
1. Residential Buildings (a) 4-storeys and below (without lift access); (b) 4-storeys and below (with lift access); (c) 5-storeys and above.	All communal areas and facilities at 1st storey. All communal areas and facilities. All communal areas and facilities.	WC at common area.	CI 2.2 and Chapter 7.
Note	:	**The table serves as a quick reference for key facilities and accessible features to be provided for the various building types. Relevant provisions that are specified in the Code shall also be complied with.	
<u>Legend</u>			
AM	:	Water closet compartment for ambulant disabled	
UGB	:	Urinal for ambulant disabled	
WC	:	Accessible Toilet	

TABLE 1 (continued)
Accessibility for Persons with Disabilities and Families with Young Children

Building Type	Accessible Areas	Key provisions to note**	
		Sanitary provision	Other provisions
2. Shophouses.	First storey for non-residential use shall be accessible to employees or the public.	WC	Minimum 1 no. WC at 1 st Storey. Where space is a constraint, an AM may be considered.
3. Office buildings.	All areas intended for access by employees or the public.	AM, UGB, WC	CI 6.8: Hearing enhancement system shall be provided. CI 4.6.1.4, 4.11.1.2 and 5.1.7: Tactile and Braille signs shall be provided.
4. Shopping complexes and multi-purpose complexes.	All areas intended for access by employees or the public.	AM, UGB, WC	CI 2.3.8: Seats and counters shall be provided. CI 6.8: Hearing enhancement system shall be provided. CI 6.9: Family-friendly facilities shall be provided. CI 4.6.1.4, 4.11.1.2 and 5.1.7: Tactile and Braille signs shall be provided.
Note	: **The table serves as a quick reference for key facilities and accessible features to be provided for the various building types. Relevant provisions that are specified in the Code shall also be complied with.		
<u>Legend</u>			
AM	: Water closet compartment for ambulant disabled		
UGB	: Urinal for ambulant disabled		
WC	: Accessible Toilet		

TABLE 1 (continued)
Accessibility for Persons with Disabilities and Families with Young Children

Building Type	Accessible Areas	Key provisions to note**	
		Sanitary provision	Other provisions
5. Hotels, boarding houses, chalets and backpackers' hotels.	All areas intended for access by employees, guests or the public.	AM, UGB, WC	<p>CI 2.3.3: 1 in 100 guest rooms to be accessible. 1 in 50 guest rooms to be elder friendly.</p> <p>CI 6.8: Hearing enhancement system shall be provided.</p> <p>CI 4.6.1.4, 4.11.1.2 and 5.1.7: Tactile and Braille signs shall be provided.</p>
6. Serviced apartments.	All areas intended for access by employees, residents, visitors, or the public.	AM, UGB, WC	<p>CI 2.3.4: 1 in 100 apartments to be accessible.</p> <p>CI 4.6.1.4, 4.11.1.2 and 5.1.7: Tactile and Braille signs shall be provided.</p>
7. Places of public resort.	All areas intended for access by employees or the public.	AM, UGB, WC	<p>CI 2.3.5: Where permanent fixed seating arrangements are provided, wheelchair spaces are to be provided.</p> <p>CI 6.8: Hearing enhancement systems shall be provided.</p> <p>CI 6.9: Family-friendly facilities shall be provided.</p> <p>CI 4.6.1.4, 4.11.1.2 and 5.1.7: Tactile and Braille signs shall be provided.</p>
Note	:	**The table serves as a quick reference for key facilities and accessible features to be provided for the various building types. Relevant provisions that are specified in the Code shall also be complied with.	
<u>Legend</u>			
AM	:	Water closet compartment for ambulant disabled	
UGB	:	Urinal for ambulant disabled	
WC	:	Accessible Toilet	

TABLE 1 (continued)
Accessibility for Persons with Disabilities and Families with Young Children

Building Type	Accessible Areas	Key provisions to note**	
		Sanitary provision	Other provisions
8. Parks and open spaces including zoos, civic plazas, etc.	All areas intended for access by employees or the public.	AM, UGB, WC	CI 2.3.5: Where permanent fixed seating arrangements are provided, wheelchair spaces are to be provided. CI 6.9: Family-friendly facilities shall be provided.
9. Sports complexes and public swimming pools.	All areas intended for access by employees or the public.	AM, UGB, WC	CI 2.3.7: At least one individual shower stall shall be accessible. CI 6.8: Hearing enhancement systems shall be provided. CI 6.9: Family-friendly facilities shall be provided. CI 4.6.1.4, 4.11.1.2 and 5.1.7: Tactile and Braille signs shall be provided.
10. Restaurants and eating establishments.	All areas intended for access by employees or the public.	AM, UGB, WC	CI 6.7: Wheelchair spaces provision for eating outlets.
11. Markets and hawkers or food centres.	All areas intended for access by employees or the public.	AM, UGB, WC	CI 6.7: Wheelchair spaces provision for eating outlets. CI 4.6.1.4, 4.11.1.2 and 5.1.7: Tactile and Braille signs shall be provided.
Note	: **The table serves as a quick reference for key facilities and accessible features to be provided for the various building types. Relevant provisions that are specified in the Code shall also be complied with.		
<u>Legend</u>			
AM	: Water closet compartment for ambulant disabled		
UGB	: Urinal for ambulant disabled		
WC	: Accessible Toilet		

TABLE 1 (continued)
Accessibility for Persons with Disabilities and Families with Young Children

Building Type	Accessible Areas	Key provisions to note**	
		Sanitary provision	Other provisions
12. Transport stations, interchanges, passenger terminals.	All areas intended for access by employees or the public.	AM, UGB, WC	<p>CI 2.3.9: At least one entrance on each side of the road shall be made accessible.</p> <p>CI 6.8: Hearing enhancement systems shall be provided.</p> <p>CI 6.9: Family-friendly facilities shall be provided.</p> <p>CI 4.6.1.4, 4.11.1.2 and 5.1.7: Tactile and Braille signs shall be provided.</p>
13. Pre-school, schools, colleges, universities or institutions of learning.	All areas intended for access by employees, students or the public.	AM*, UGB*, WC	<p>*AM and *UGB are not required in pre-schools, primary and secondary schools.</p> <p>CI 6.8: Hearing enhancement systems shall be provided.</p> <p>CI 4.6.1.4, 4.11.1.2 and 5.1.7: Tactile and Braille signs shall be provided except for pre-school and school.</p>
Note	: **The table serves as a quick reference for key facilities and accessible features to be provided for the various building types. Relevant provisions that are specified in the Code shall also be complied with.		
<u>Legend</u>			
AM	: Water closet compartment for ambulant disabled		
UGB	: Urinal for ambulant disabled		
WC	: Accessible Toilet		

TABLE 1 (continued)
Accessibility for Persons with Disabilities and Families with Young Children

Building Type	Accessible Areas	Key provisions to note**	
		Sanitary provision	Other provisions
14. Hostels, halls of residence or dormitories.	All areas intended for access by employees, residents, students or the public.	AM*, UGB*, WC	<p>CI 2.3.6: At least one in every 100 rooms or shall be accessible.</p> <p>*AM and *UGB are not required in hostels and halls of residence or dormitories for primary and secondary schools.</p> <p>CI 6.8: Hearing enhancement systems shall be provided.</p> <p>CI 4.6.1.4, 4.11.1.2 and 5.1.7: Tactile and Braille signs shall be provided.</p>
15. Hospitals, clinics, nursing homes, homes for the aged and welfare homes.	All areas intended for access by patients, residents, employees or the public.	AM, UGB, WC	<p>Sanitary facilities within the wards or homes for patients/residents are to be provided in accordance with the hospitals' and homes' requirements and needs.</p> <p>CI 6.8: Hearing enhancement systems shall be provided in hospitals and clinics.</p> <p>CI 4.6.1.4, 4.11.1.2 and 5.1.7: Tactile and Braille signs shall be provided in hospitals and clinics.</p>
Note	:	**The table serves as a quick reference for key facilities and accessible features to be provided for the various building types. Relevant provisions that are specified in the Code shall also be complied with.	
<u>Legend</u>			
AM	:	Water closet compartment for ambulant disabled	
UGB	:	Urinal for ambulant disabled	
WC	:	Accessible Toilet	

TABLE 1 (continued)
Accessibility for Persons with Disabilities and Families with Young Children

Building Type	Accessible Areas	Key provisions to note**	
		Sanitary provision	Other provisions
16. Factories, workshops, industrial buildings and office/showroom areas in warehouses.	All areas intended for access by employees or the public.	WC	CI 2.3.11: Exception areas applicable.
17. Workers dormitory.	Designated area leading to accessible room.	WC	There shall be at least one accessible room with accessible toilet and shower facilities.
18. Vehicle parks (Surface parking or vehicle parking buildings).	For vehicle parking buildings, at least 50% of car park decks are to be made accessible.		CI 3.5: Accessible parking lots provision to comply with Table 2.
19. Taxi and bus shelters.	All areas intended for access by the public.		CI 3.4: Taxi shelters.
Note	: **The table serves as a quick reference for key facilities and accessible features to be provided for the various building types. Relevant provisions that are specified in the Code shall also be complied with.		
<u>Legend</u>			
AM	: Water closet compartment for ambulant disabled		
UGB	: Urinal for ambulant disabled		
WC	: Accessible Toilet		

2.2 RESIDENTIAL DEVELOPMENT

Residential development

2.2.1 All communal areas and facilities within a residential development shall be made accessible for persons with disabilities in accordance with the provisions of this Code.

2.2.2 For residential development of 4 storey buildings and below without lift access, all communal areas and facilities at 1st storey level shall be accessible.

Exception

- 2.2.3 In the residential unit, Requirements within the residential units
- (a) difference in levels between the floor of the entrance to the unit and the abutting common area shall not be more than 50 mm with manoeuvring space complying with clause 7.2;
 - (b) there shall be at least one bathroom with toilet and shower/bathing facilities in every residential unit that can be retrofitted for older persons and wheelchair users complying with clause 7.3; and
 - (c) switches and socket outlets shall be provided at a height of between 450 mm and 1200 mm from the floor level, complying with clause 7.4.
- Note:
- (1) *Clause 2.2.3 shall not apply to non- strata landed housing and serviced apartments.*
 - (2) *Height of socket outlets in residential units' kitchen shall not be required to comply with clause 7.4.1.*

2.3 MINIMUM ACCESSIBLE PROVISIONS

- 2.3.1 **Banks and ticketing offices** Banks and ticketing offices
- 2.3.1.1 At least one service counter shall be provided in banks and ticketing offices for wheelchair users and persons with hearing impairment in accordance with the requirements of service and information counter and hearing enhancement system in clauses 6.4 and 6.8 respectively.
- 2.3.2 **Service booths** Service booths
- 2.3.2.1 Where kiosks and/or dispensers such as automatic teller machines (ATMs), cash dispensers, cash deposit machines, electronic service stations (eg. AXS, SAM, multimedia kiosks), library book-drops are provided; at least one kiosk and/or dispenser shall be made accessible.
- 2.3.3 **Hotels, boarding houses, chalets and backpacker hotels** Hotels, boarding houses, chalets and backpackers' hotels
- 2.3.3.1 In hotels, boarding houses, chalets and backpacker hotels, at least one in every 100 guestrooms or part thereof shall be accessible.
- 2.3.3.2 In addition to clause 2.3.3.1, at least one in every 50 guestrooms or part thereof shall be provided with elder-friendly features such as grab bars in bathrooms and toilets.
- 2.3.3.3 At least one service and information counter shall be provided for wheelchair users and persons with hearing impairment in accordance with the requirements of service and information counters and hearing enhancement systems in clauses 6.4 and 6.8 respectively.

Note: *For hotels, boarding houses, chalets or backpacker hotels that are expected to cater to a larger number of persons with disabilities, the owners are encouraged to provide over and above the required minimum number of guestrooms.*

2.3.4	Serviced apartments	Serviced apartments
2.3.4.1	In service apartments, one in every 100 apartments or part thereof shall be accessible.	
2.3.5	Cinemas, theatres, concert halls, stadia or other places of public resort	Cinemas, theatres, concert halls, stadia or other places of public resort
2.3.5.1	In cinemas, theatres, concert halls, stadia or other places of public resort where permanent fixed seating arrangements are provided, a minimum of two wheelchair spaces shall be provided where there are 200 seats or less. Additionally, one wheelchair space shall be provided for every subsequent 200 seats or part thereof.	
2.3.5.2	The wheelchair spaces, each measuring 900 mm wide by 1200 mm deep, shall be located alongside the fixed seats to enable wheelchair users to sit together with their able-bodied or ambulant companion.	
2.3.5.3	At least one service and information counter shall be provided for wheelchair users and persons with hearing impairment in accordance with the requirements of service and information counters and hearing enhancement systems in clauses 6.4 and 6.8 respectively.	
Note:	<p>(1) <i>Wheelchair spaces should be an integral part of any seating plan. Efforts must be made to disperse the seating spaces throughout the seating area and in each pricing tier.</i></p> <p>(2) <i>Persons in wheelchairs usually sit higher and their viewing positions should be arranged so as not to obstruct the view of persons who may be seated behind.</i></p>	
2.3.6	Hostels, halls of residence or dormitories	Hostels, halls of residence or dormitories
2.3.6.1	In hostels, halls of residence or dormitories, at least one in every 100 rooms or part thereof shall be accessible.	
2.3.6.2	Hearing enhancement system shall be provided in accordance with clause 6.8.	
2.3.7	Sports complexes and public swimming pools	Sports complexes and public swimming pools
2.3.7.1	In sports complexes and public swimming pools at least one individual shower stall shall be accessible.	

2.3.7.2 At least one service and information counter shall be provided for wheelchair users and persons with hearing impairment in accordance with the requirements of service and information counters and hearing enhancement systems in clauses 6.4 and 6.8 respectively.

2.3.8 **Departmental stores, supermarkets, foyers and public concourses**

Departmental stores, supermarkets, foyers and public concourses

2.3.8.1 In departmental stores, supermarkets, foyers of places of public resort and public concourses, seats shall be provided for persons who are unable to stand for long periods.

2.3.8.2 At least one accessible checkout lane and counter shall be provided.

2.3.8.3 At least one service and information counter shall be provided for wheelchair users and persons with hearing impairment in accordance with the requirements of service and information counters and hearing enhancement systems in clauses 6.4 and 6.8 respectively.

Note: (1) *It is recommended that seats be provided with armrests or grab bars to assist older persons or persons with disabilities to get up from the seats.*

(2) *Where changing rooms are provided in departmental stores or supermarkets, it is recommended that at least one accessible changing room should be provided with foldable door, swing out doors or curtain. The size of room should have a minimum dimension of 1000 mm X 1200 mm.*

2.3.9 **Halls and Auditoriums**

Halls and auditoriums

2.3.9.1 In halls and auditoriums where permanent fixed seating arrangement is provided, a minimum of two wheelchair spaces shall be provided where there are 200 seats or less. Additionally, one wheelchair space shall be provided for every subsequent 200 seats or part thereof.

2.3.9.2 The wheelchair spaces, each measuring 900 mm wide by 1200 mm deep, shall be located alongside the fixed seats to enable wheelchair users to sit together with their able-bodied or ambulant companion.

2.3.9.3 Hearing enhancement system shall be provided in accordance with clause 6.8.

2.3.10 **Transport stations and Interchanges**

Transport stations and interchanges

2.3.10.1 Where entrances are located across roads, at least one entrance on each side of the road shall be made accessible.

2.3.10.2 At least one service and information counter shall be provided for wheelchair users and persons with hearing impairment in accordance with the requirements of service and information counters and hearing enhancement systems in clauses 6.4 and 6.8 respectively.

2.3.11 **Industrial buildings**

Industrial buildings

2.3.11.1 Except the following areas, all areas in the industrial buildings intended for access by employees or the public shall be accessible:

- (a) Process plant and structure which deals with oil and gas industry, refinery industry, chemical industry and premises which handle chemicals, toxic materials and potential explosive compounds. This includes ancillary office areas located within the same development;
- (b) Areas with activities that require a "gowning regime" (e.g. clean or sterile rooms, etc.);
- (c) Production areas with heavy machinery, etc.;
- (d) Areas used for warehousing and storage.

2.3.11.2 For flatted factories or industrial buildings for multiple users, at least one accessible washroom shall be provided at one of the toilet cluster common area of every level.

2.4 **INTER-CONNECTIVITY**

Barrier-free inter-connectivity

2.4.1 The provisions of this Code apply to building works within the development and it shall be read in conjunction with LTA's and NParks' guidelines where street work/public footpaths and public open spaces/parks are involved respectively. Where interfaces between buildings and from building to infrastructures are involved, the developer/owner of the building works shall ensure that accessibility right up to the interface is considered.

2.4.2 An access route plan showing the primary access route connecting from the infrastructure to the entrance of the building and primary access route within the building shall be provided for building plan approval.

Access route plan

2.4.3 Footpaths in road reserve abutting development under construction shall be kept barrier-free, unobstructed and free of construction activities and equipment. The footpath shall be adequately protected from the debris of construction work.

Public footpath

2.4.4 In the event that the existing accessible public footpath has to be temporarily removed or altered, an alternative accessible footpath with a minimum width of 1200 mm has to be provided in addition to signage to direct users.

2.5 EXEMPTIONS

General exceptions

2.5.1 The provisions of this Code shall not apply to the areas which would pose a health or safety risk for persons with disability. These areas include the following:

- (a) Construction sites and structures which are directly associated with process of construction;
- (b) Areas which are raised primarily for purposes of security, life safety, or fire safety, including but not limited to, observation or lookout galleries, prison guard towers, fire towers or life guard stands;
- (c) Plants, equipment rooms and machinery spaces;
- (d) Loading docks.

2.6 ALTERATIONS AND ADDITIONS WORKS

Alterations and additions works

2.6.1 The provision of this Code shall apply to all new areas and existing areas with extensive alteration works which requires plan submission and approval from Building Control.

CHAPTER 3

ARRIVING AT THE BUILDING

Objective : Accessible Approach and Entry

All users shall be able to arrive on the site, approach the building as well as enter safely and independently. At least one route of travel shall be safe and accessible for everyone, including persons with disabilities.

- | | | |
|---|--|---------------|
| ▪ | Access to Buildings | CI 3.1 |
| ▪ | Approach to Buildings | CI 3.2 |
| ▪ | Passenger Alighting and Boarding Points | CI 3.3 |
| ▪ | Taxi Shelters | CI 3.4 |
| ▪ | Accessible Vehicle Parking | CI 3.5 |
| ▪ | Kerb Ramps | CI 3.6 |
| ▪ | Pedestrian Crossing | CI 3.7 |

3.1 ACCESS TO BUILDINGSAccess and
entrance

3.1.1 The buildings specified in Table 1 of Chapter 2 shall be provided with at least one accessible entrance door served by an approach complying with clause 3.2.

3.1.2 The access shall be through the main entrance of the building.

Note: *If there are other main entrances, such entrances should also be made accessible.*

3.1.3 Directional signs bearing the symbol of access shall be displayed at all other non-accessible entrances to direct persons with disabilities to the accessible entrance.

3.1.4 At least one accessible route leading to an accessible entrance of the building shall be provided from the alighting and boarding point of taxi shelters, bus shelters (if any) and vehicle parking lots for persons with disabilities.

3.1.5 The width of the accessible entrance door shall not be less than 850 mm as described in clause 4.4 and the width of corridors or passageways leading to and from such access doors shall be in accordance with clause 4.2.

3.1.6	A permanent floor diagram on durable material indicating the accessible routes and facilities shall be displayed at an appropriate place in every storey of a non-residential building. In the case of residential buildings, it shall be displayed at an appropriate place where common facilities are provided.	Overall floor diagram
3.2	APPROACH TO BUILDINGS	Approach to buildings
3.2.1	A passenger alighting and boarding point complying with clause 3.3 should, where possible, be provided at the level of approach for persons with disabilities to alight from and board a vehicle.	
3.2.2	Where transfers have to be made from vehicular surfaces to pedestrian surfaces, the driveways and pavements or footway surfaces shall be ramped or blended to a common level.	
3.2.3	Differences in levels between driveways and pavements or footways shall be avoided. Where the difference is unavoidable, such drops shall comply with clause 4.5 and Table 4.	
3.3	PASSENGER ALIGHTING AND BOARDING POINTS	Alighting and boarding points
3.3.1	At least one alighting and boarding point, if provided, shall be sheltered.	
3.3.2	Where there is a level difference, a passenger alighting and boarding point, as illustrated in Figure 1 (a), shall: <ul style="list-style-type: none"> (a) provide an access aisle of at least 1200 mm wide by 4500 mm long adjacent and parallel to the vehicle pull-up space; (b) have a kerb ramp complying with clause 3.6 if there is a kerb between the access aisle and the vehicle pull-up space. 	
3.3.3	Where there is no level difference, a warning indicator with contrasting colour shall be provided.	

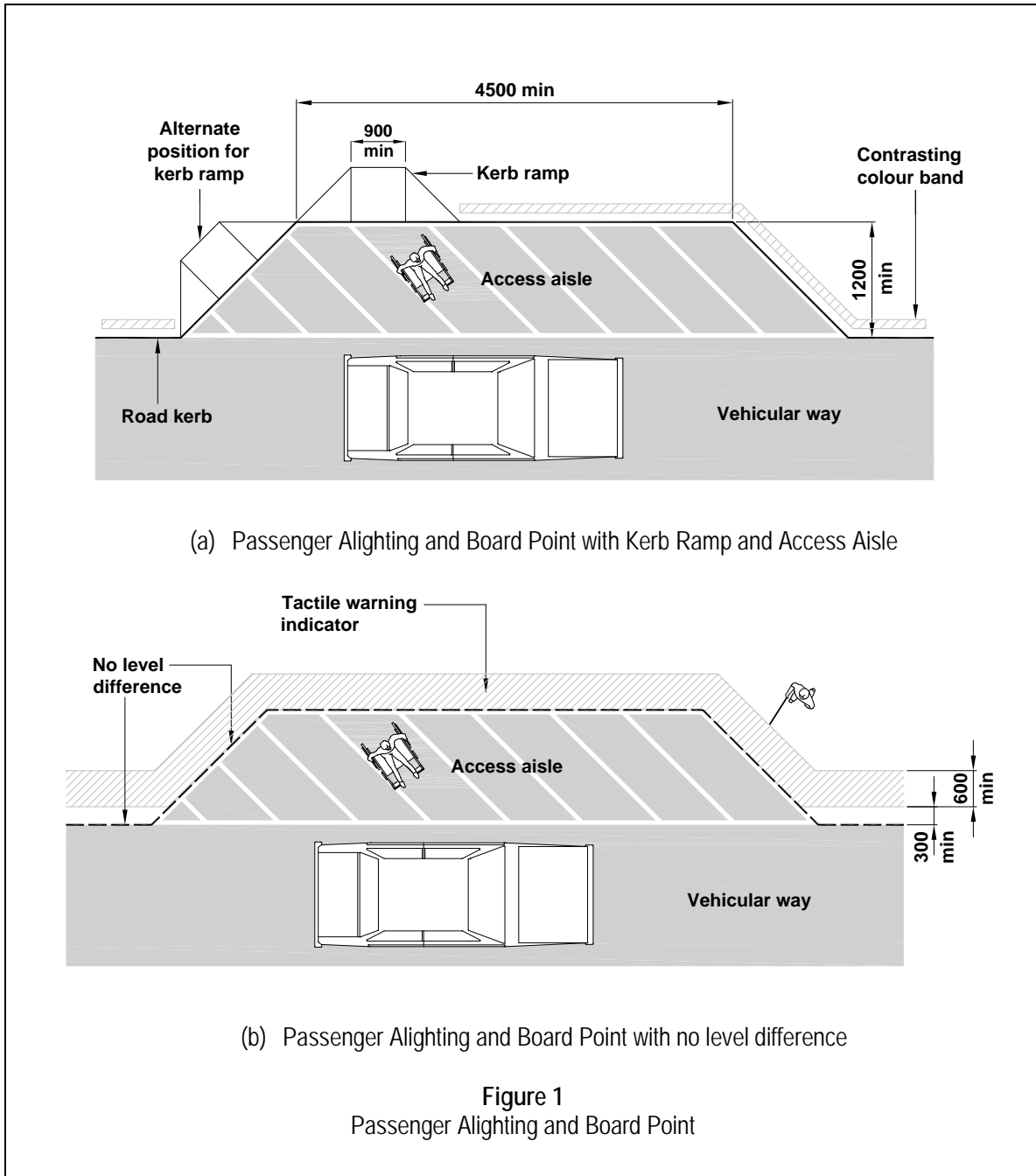

- Note:
- (1) Where bollards are used, it shall comply with clause 4.2.4.5.
 - (2) Bollards should be identifiable by using contrasting colours and should not be linked with ropes or chains to minimize hazard for people with visual impairment.

3.4 TAXI SHELTERS

Taxi shelters

3.4.1 General

3.4.1.1 At least one accessible route shall be provided from the alighting and boarding point of a taxi shelter to the walkway that leads to the accessible building entrance.

3.4.1.2 The symbol of access, in accordance with the requirements of Chapter 8, shall be installed to direct persons with disabilities to an accessible entrance.

3.4.2 Location

3.4.2.1 Taxi shelters should be located as near as possible to an accessible entrance.

3.4.2.2 A taxi bay should, where possible, be provided at the level of approach for persons with disabilities to alight and to board the vehicle.

3.4.2.3 Where transfers have to be made from a vehicular surface to a pedestrian surface, the driveways, pathways or walkways shall be blended to a common level or ramped in accordance with Table 4 of Chapter 4.

3.4.3 Width

3.4.3.1 A clear passageway with a minimum width of 1200 mm as shown in Figure 2 shall be provided.

3.4.4 Handrails

3.4.4.1 Where handrails are provided, it shall:

- (a) comply with clause 4.7; and
- (b) be placed at a height of between 800 mm and 900 mm from the floor level.

3.4.5 Ramps

3.4.5.1 Where a taxi shelter is not on the same level with the access aisle, it shall have two separate ramps, conforming to Table 4 of Chapter 4, for boarding and alighting as shown in Figure 2.

3.4.5.2 Where there are kerbs between the access aisle and the vehicle pick-up space, it shall have a kerb ramp complying with clause 3.6.

3.4.6 Seats

3.4.6.1 Seats shall be provided at the taxi shelter for the ambulant disabled and these shall not impede the movement of the wheelchair user.

3.4.6.2 Suitable armrests should be provided at the ends of the seats to assist ambulant disabled and older persons to get up.

Note: *Bum rests should be avoided as they are not suitable for ambulant disabled or older persons.*

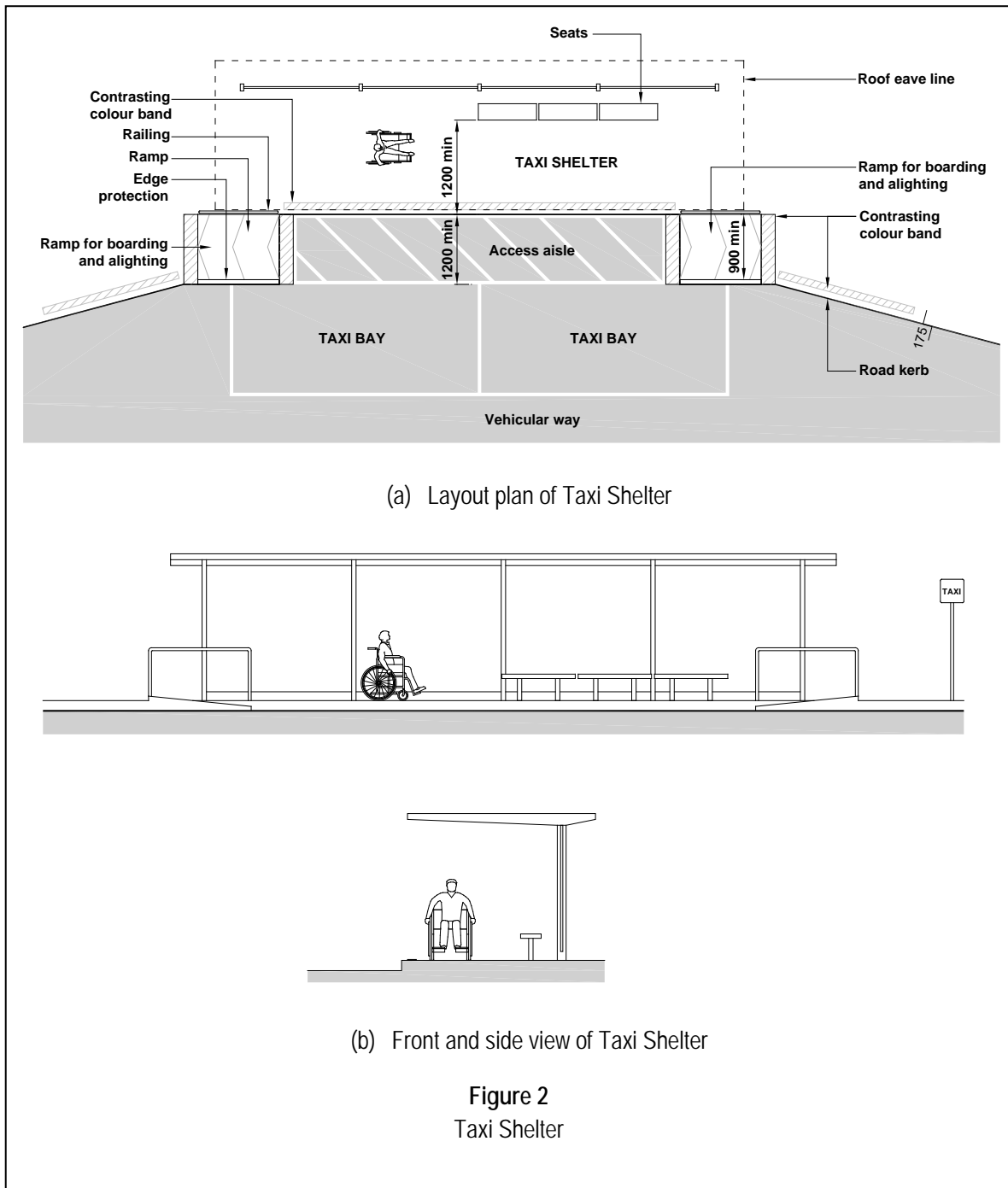

3.5 **ACCESSIBLE VEHICLE PARKING** Vehicle park

3.5.1 **Parking Provision** Parking provision

3.5.1.1 Where vehicle parks are required to be provided, the number of accessible parking lots for vehicles driven by persons with disabilities shall be in accordance with Table 2:

TABLE 2
Accessible Parking Lots

Number of vehicle park lots	Number of accessible lots
First 50 lots (1-50)	1
Next 50 lots (51-100)	1
Every subsequent 200 lots or any part thereof	1

Note: (1) *The number of accessible parking lots provided shall be over and above the LTA's minimum parking requirements.*

(2) *However, for small developments where the minimum requirements for car parking lots is 10 or less, no additional accessible parking lot is required provided one of the lots is designed and constructed in accordance with the specification in the Code but without displaying the Symbol of Access. Should the need arise; the car parking lot can be converted into an accessible lot.*

3.5.2 **Accessible Vehicle Parking Lots**

3.5.2.1 An accessible vehicle parking lot shall: Accessible vehicle parking lots

- (a) have a firm, level surface without aeration slabs;
- (b) have the minimum dimensions of 4800 mm by 3600 mm for angled parking as illustrated in Figure 3; and
- (c) have the minimum dimensions of 5400 mm by 3600 mm for parallel parking as illustrated in Figure 4. For parallel parking, where vehicles cannot be parked by reversing or where there are obstructions at the ends of the parking spaces, minimum stall length shall be 7200 mm.

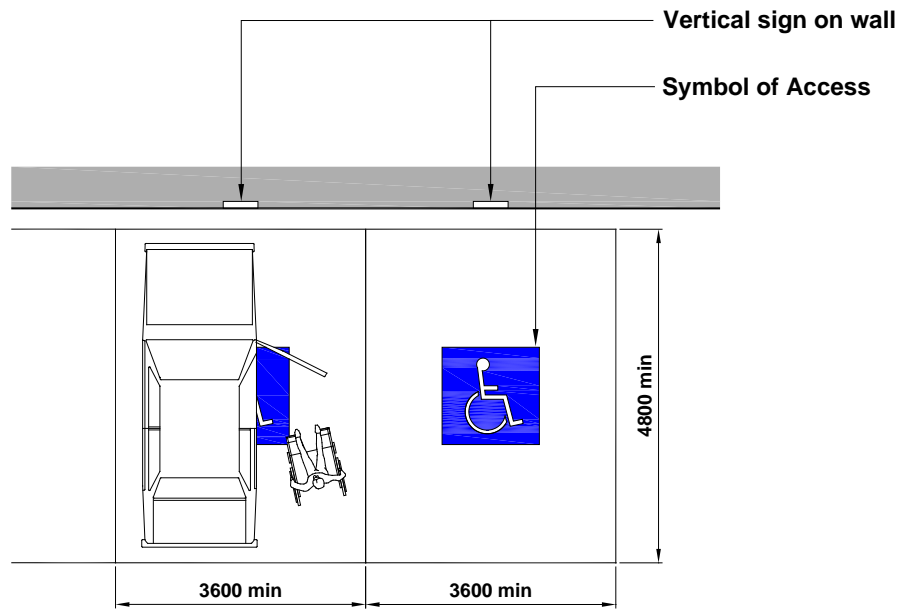

Figure 3
Angled Parking for Accessible Lots

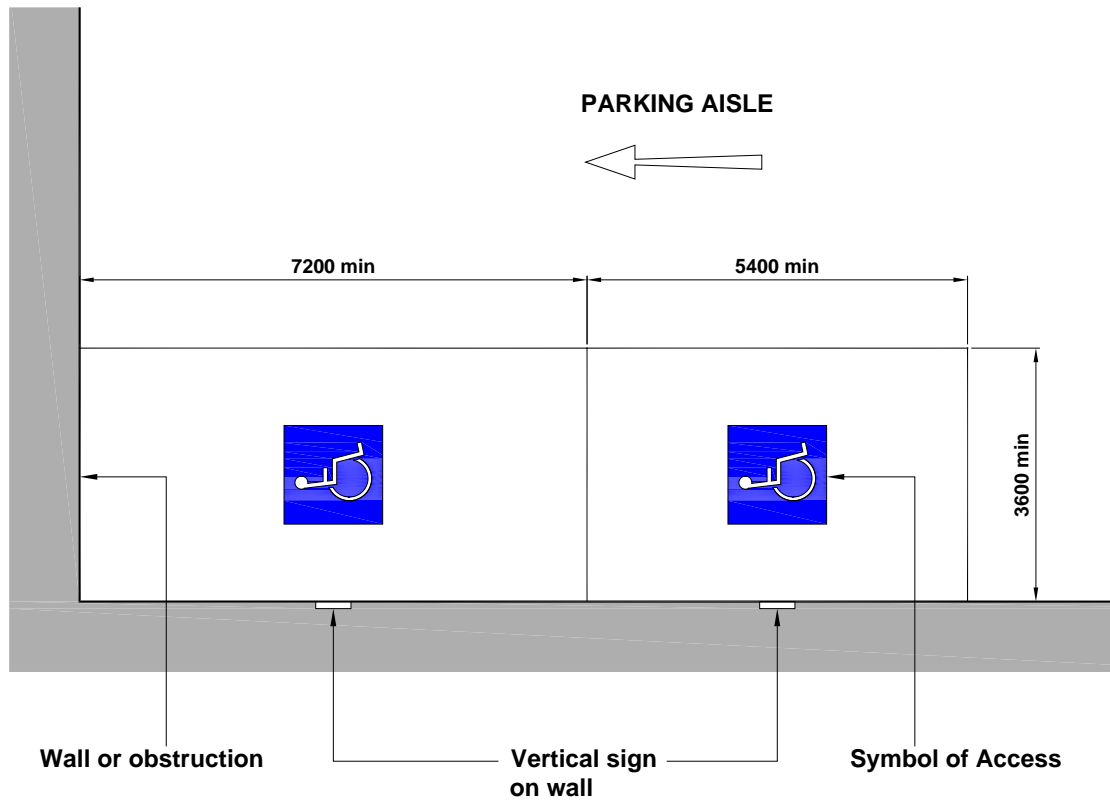

Figure 4
Parallel Parking for Accessible Lots

3.5.3 Vehicle Park Entrance

3.5.3.1 Clear directional signs shall be displayed at appropriate places to direct drivers with disabilities to the location of accessible parking lots before approaching the vehicle park entrance.

3.5.3.2 Vehicle park entrances shall have a height clearance of at least 2000 mm.

3.5.4 Location

3.5.4.1 Accessible parking lots that serve a particular building shall be located as close as possible to an accessible entrance and/or lift lobby.

3.5.4.2 For a vehicle park that does not serve a particular building, accessible parking lots shall be linked to an accessible walkway which shall not be part of the driveway.

3.5.4.3 The accessible route should not require wheelchair users to pass behind vehicles that may be backing out.

Note: *It is recommended that the minimum lighting for accessible parking lots should be in accordance with the current edition of SS 531.*

3.5.5 Accessible Entrance

3.5.5.1 An accessible path leading to the entrance of the building, as shown in Figure 5, shall be level or have a kerb ramp complying with clause 3.6.

Accessible
entrance

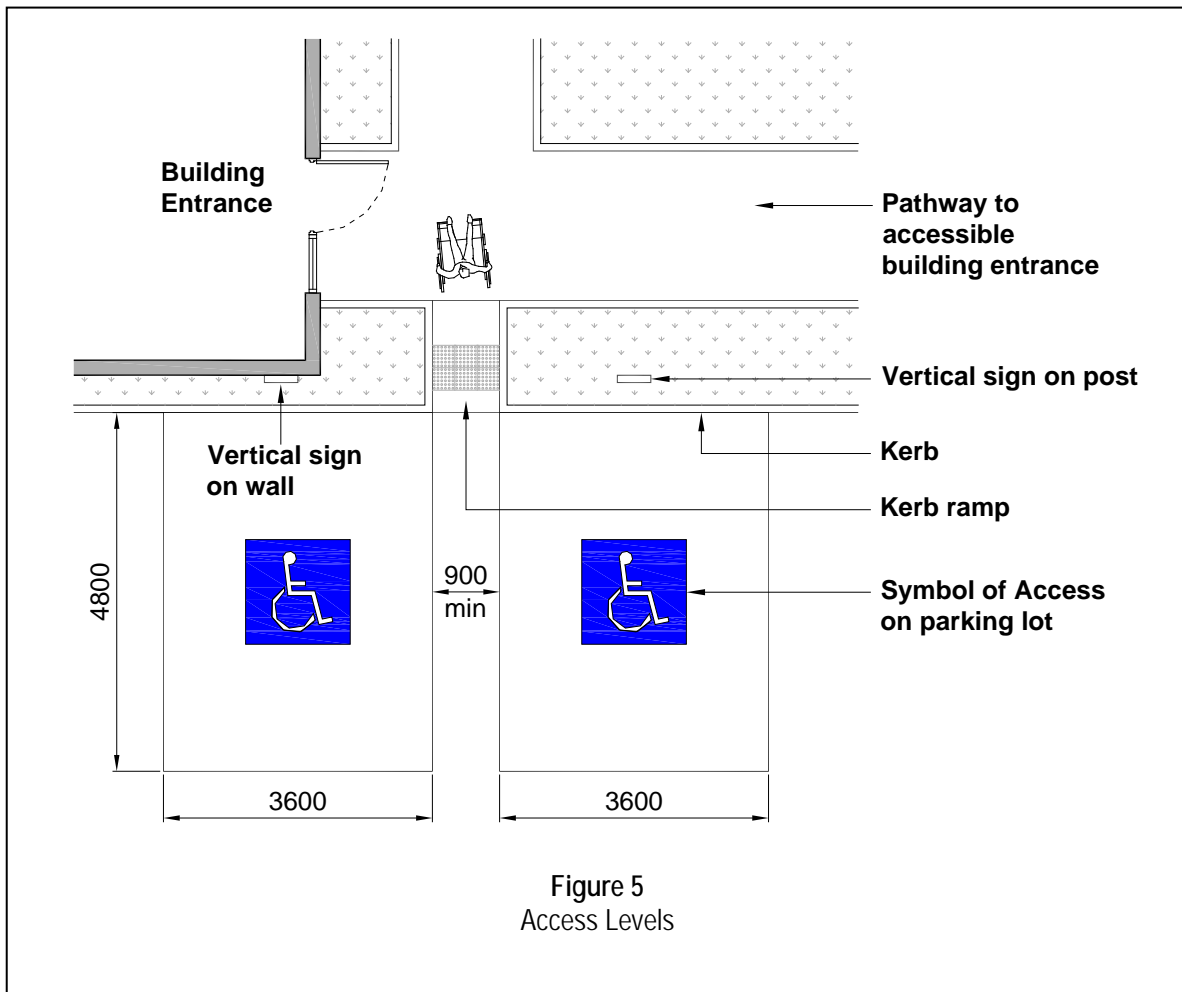

3.5.6 **Auto-pay machines**

3.5.6.1 Vehicle park auto-pay machines shall:

Auto-pay machines

- (a) be located on the same level as the accessible vehicle parking lots; and
- (b) have the operable parts complying with clause 6.2.

3.5.7 **Symbol of Access**

Symbol of access

3.5.7.1 The Symbol of Access, in accordance with the requirements of Chapter 8, shall be clearly marked on the accessible parking lots for vehicles driven by persons with disabilities only.

3.5.7.2 The Symbol of Access painted or marked on the designated lot shall comply with clause 8.2.2 and the following:

- (a) a white stylized figure with dimensions of at least 1000 mm but not more than 1500 mm in length on a blue background; and

(b) be located in the centre of the lot.

3.5.8 Signage

Signage

3.5.8.1 The Symbol of Access in accordance with clause 8.2.2 shall be displayed at entrances to car parks to indicate the provision of accessible vehicle parking lots for persons with disabilities within the parking vicinity.

3.5.8.2 Directional signs as shown in Figure 6 shall be displayed at points where there is a change of direction to direct persons with disabilities to the accessible parking lots.

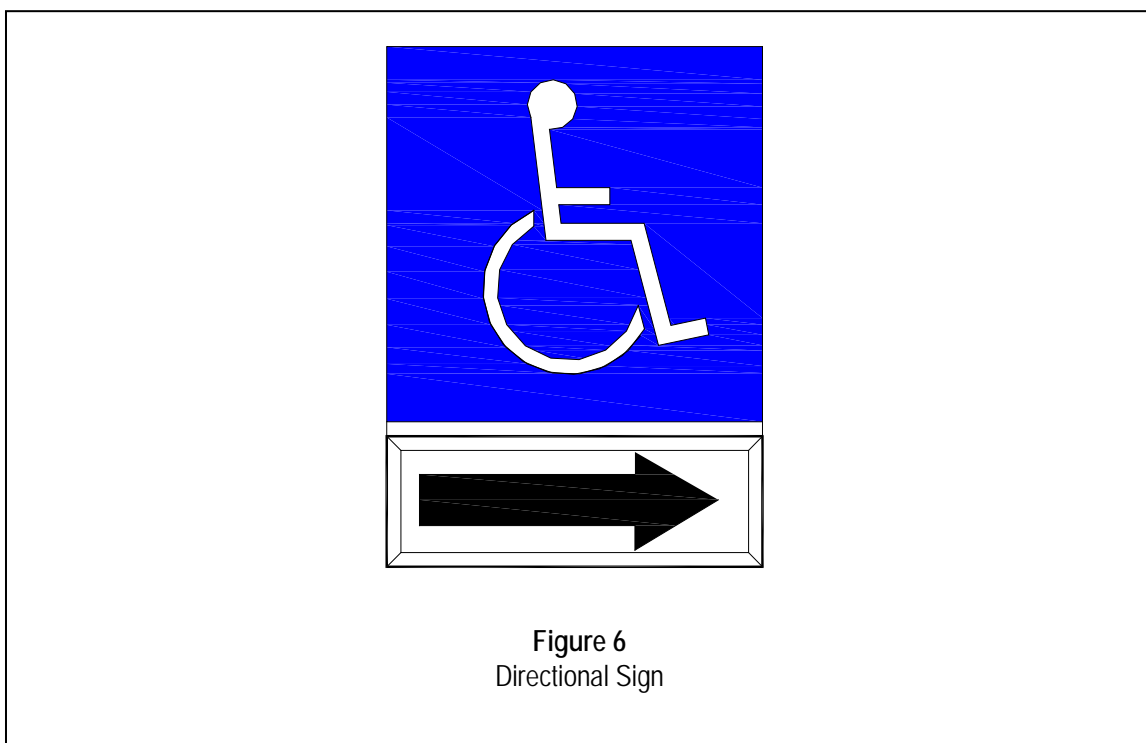

3.5.8.3 Where the location of the accessible parking lots is not obvious or is distant from the approach viewpoints, directional signs should be placed along the route leading to the accessible parking lots.

3.5.8.4 Accessible parking lots shall be identified by the Symbol of Access in accordance with clause 8.2.2. A vehicle parked in the designated lot shall not obscure such signs.

3.5.8.5 Vertical signs shall be provided immediately adjacent to the parking lots to make them readily visible. Examples of signage at accessible parking lots are as shown in Figure 7.

3.5.8.6 Vertical signs shall:

- (a) have dimensions of at least 450 mm by 450 mm;
- (b) be installed at a height of at least 1500 mm from the floor surface to the centre of the sign; and
- (c) have the telephone number of the building management, Town Council or the relevant authority clearly printed on them for the purpose of reporting unauthorised parking.

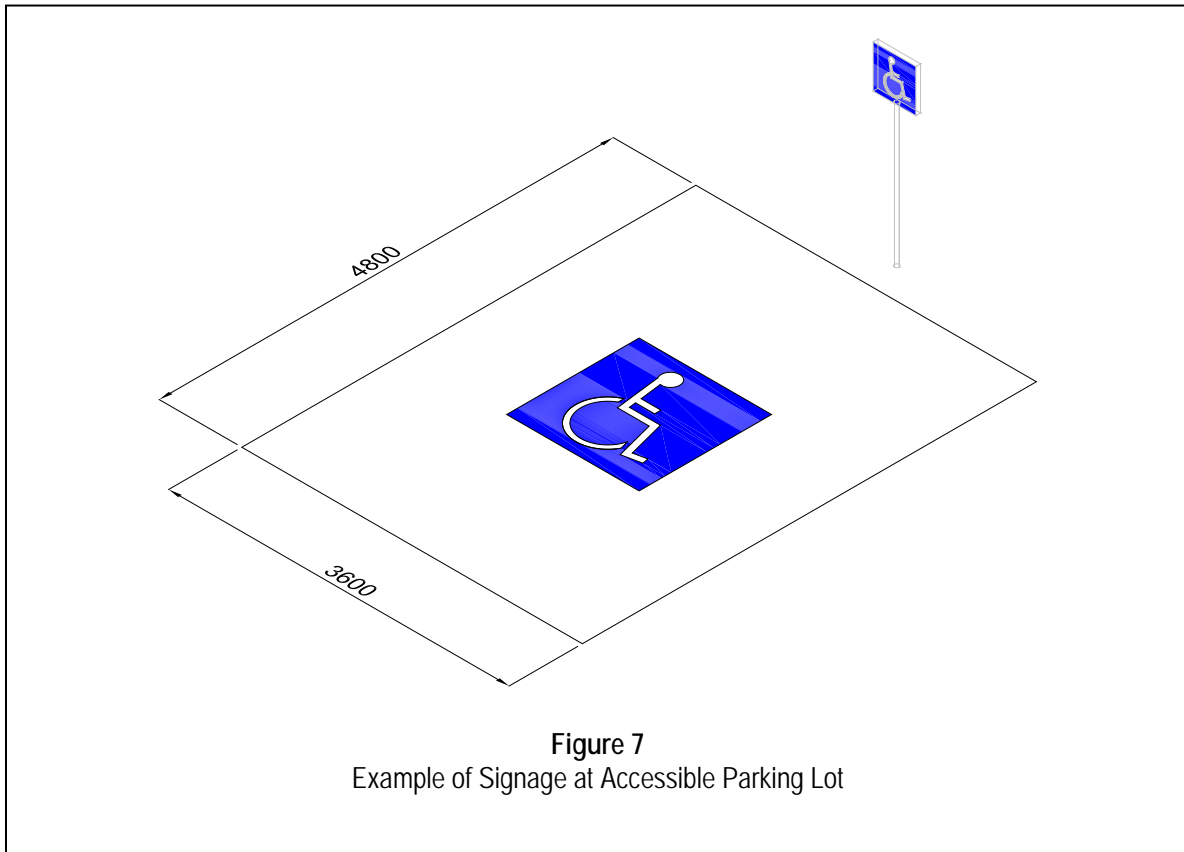

3.6 KERB RAMPS

Kerb ramps

3.6.1 General

3.6.1.1 Kerb ramps:

- (a) do not require handrails;
- (b) shall not project onto a road surface;
- (c) shall be located or protected to prevent obstruction by parked vehicles; and
- (d) shall be free from any obstruction, such as signposts, traffic lights, bollards and the like.

- 3.6.1.2 The gradient of a kerb ramp shall not be steeper than 1:10.
- 3.6.1.3 The width of a kerb ramp shall be at least 900 mm.
- 3.6.1.4 Where the vertical rise is greater than 175 mm, the kerb ramp shall also conform to the requirements of clause 4.6.
- 3.6.1.5 Surfaces of kerb ramps shall:
 - (a) be slip-resistant;
 - (b) have a detectable warning surface 600 mm depth where the colour and texture are contrasted with the adjacent surfaces; and
 - (c) where kerb ramps are located at road crossings or other identified paths intended for pedestrian use in crossing a vehicular way, the detectable warning surface shall be of tactile warning indicators.

Tactile warning indicator

Note: *A textured surface will assist in giving a secure foothold to the ambulant disabled. Use of detectable surface at change in levels will assist persons with visual impairment. Tactile warning indicators shall be used at areas where pedestrian ways meet vehicular ways at the same level.*

3.6.2 Kerb ramp with flared sides

Kerb ramp with flared sides

3.6.2.1 Kerb ramps shall have flared sides where pedestrians are likely to walk across them as shown in Figure 8.

3.6.2.2 The gradient of the flared sides shall not be steeper than 1:10.

3.6.3 Kerb ramps with returned/continuous kerbs

Returned/continuous kerbs ramp

3.6.3.1 Kerb ramps with returned/continuous kerbs as shown in Figure 9 are an alternative approach that can be used where pedestrians are not expected to walk across the ramp.

3.6.4 Kerb ramps with built-up/extended kerbs

Built-up/extended kerbs

3.6.4.1 Kerb ramps with built-up or extended kerbs as shown in Figure 10 are not recommended if they project into roadways as they are dangerous to users and obstructive to vehicles.

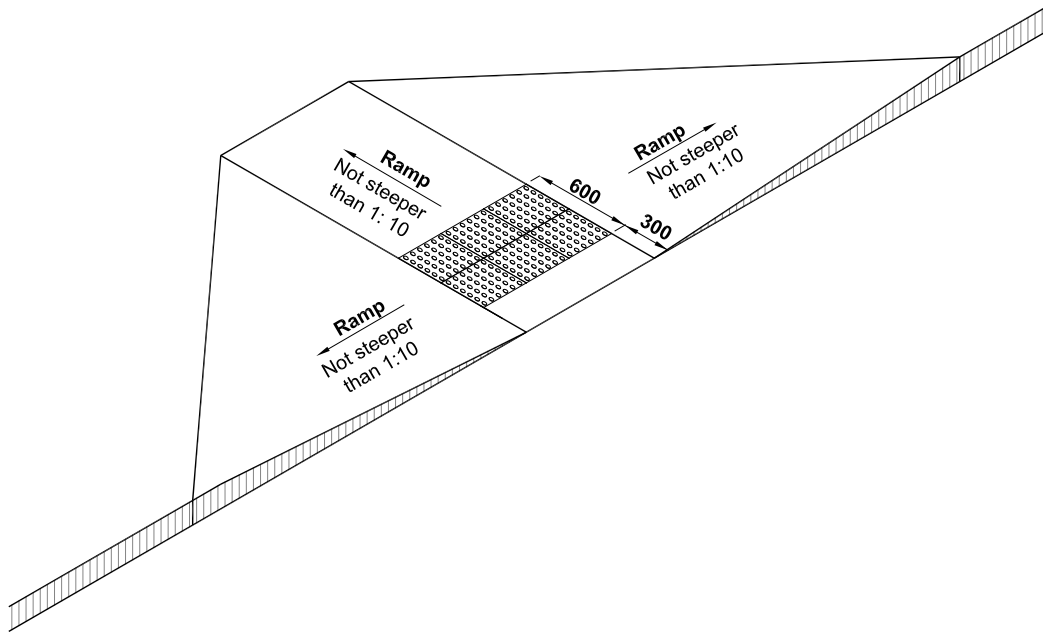

Figure 8
Kerb Ramp with Flared Sides

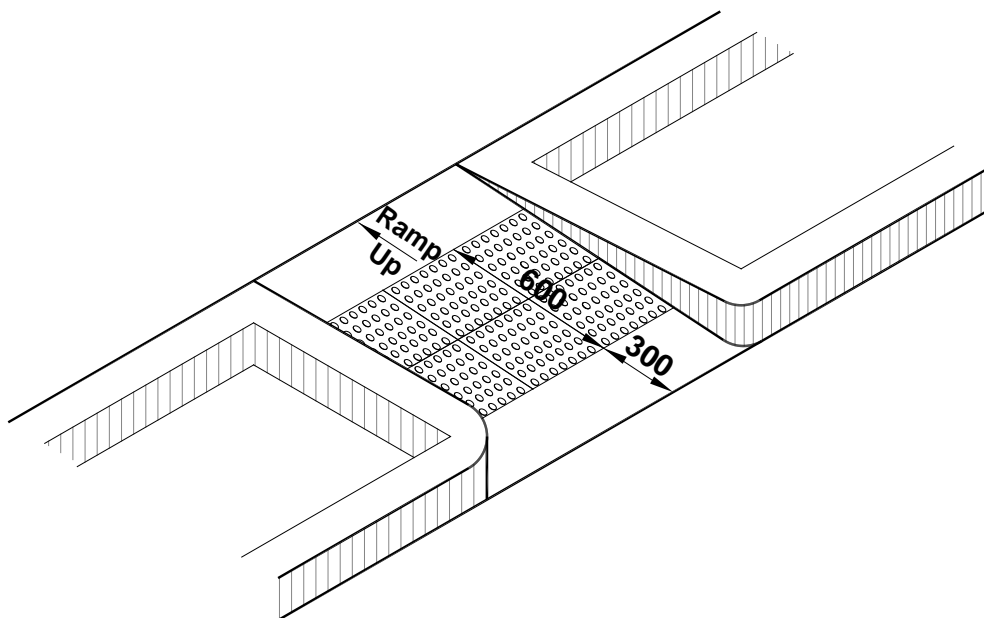

Figure 9
Kerb Ramp with Returned/Continuous Kerbs

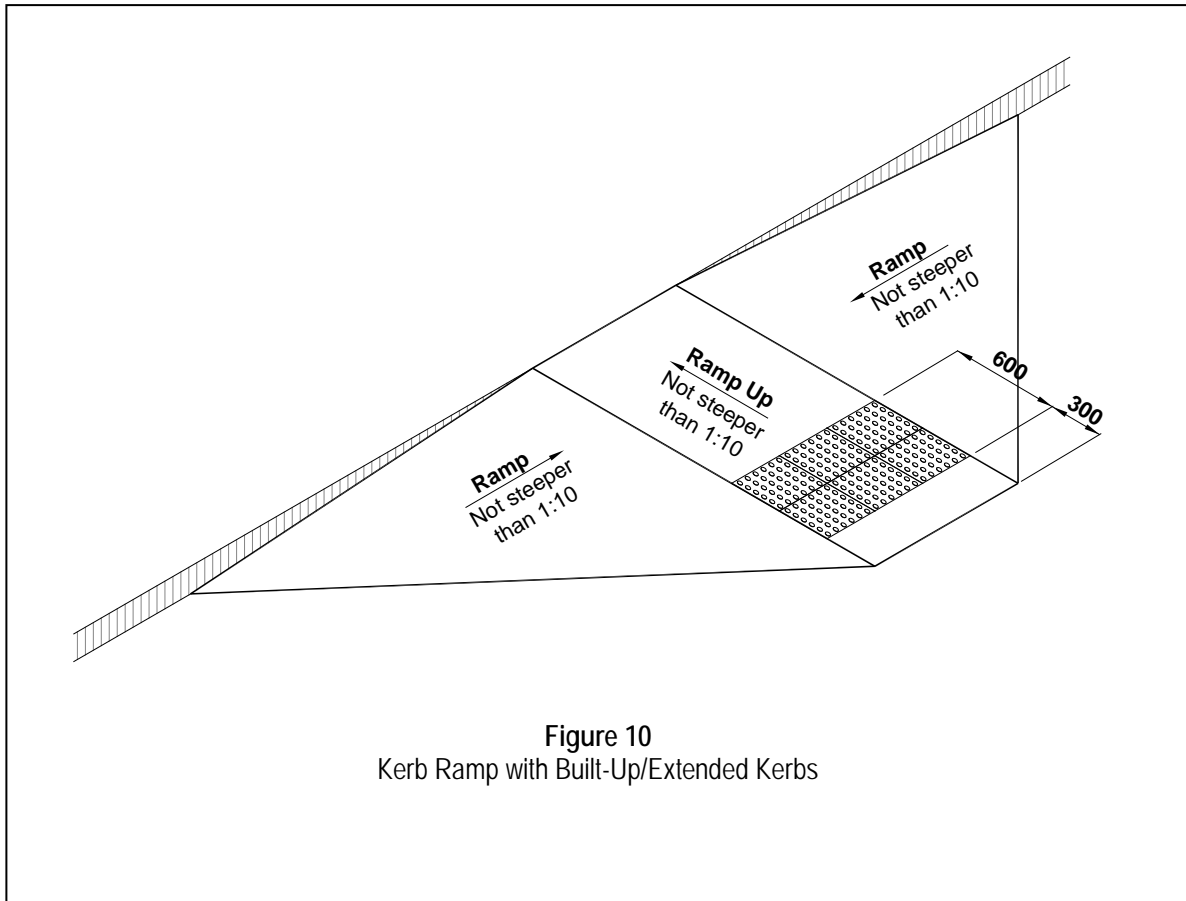

Figure 10
Kerb Ramp with Built-Up/Extended Kerbs

3.7 PEDESTRIAN CROSSING

Pedestrian crossing

3.7.1 Location at Pedestrian Crossing

3.7.1.1 Kerb ramps at pedestrian crossings shall be wholly contained within the area designated for pedestrians' use as shown in Figure 11.

3.7.1.2 Detectable warning surfaces in the form of tactile surface ground indicators used at pedestrian crossings and kerb ramps shall be in accordance with clause D4 in Appendix D, Design Guidelines for Persons with Visual Impairment.

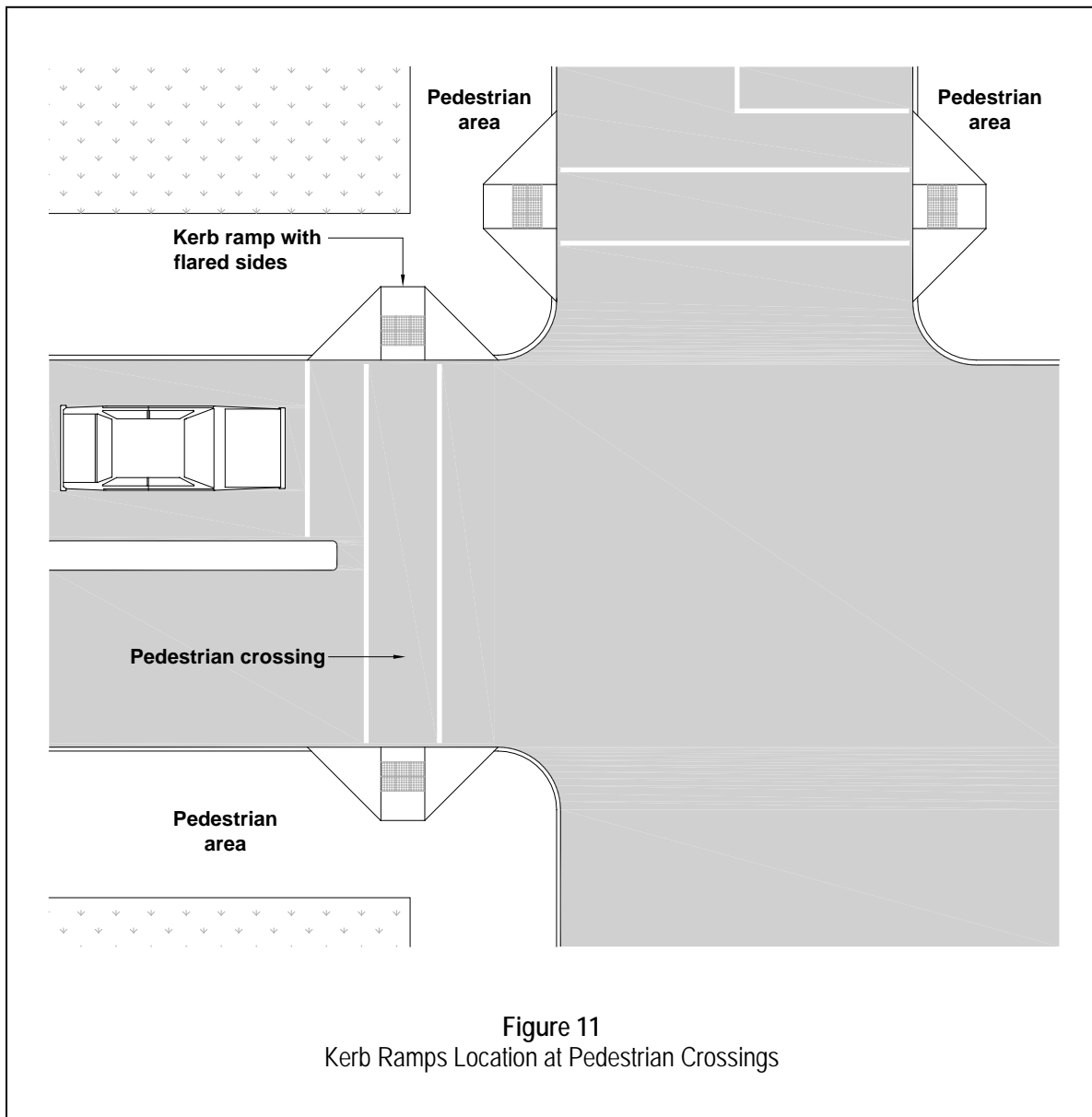

Figure 11
Kerb Ramps Location at Pedestrian Crossings

3.7.2 Islands

3.7.2.1 Raised islands in crossings shall:

- (a) be cut through and level with the street; or
- (b) have kerb ramps at both sides and have a level area of 1200 mm long or more in the middle as shown in Figure 12.

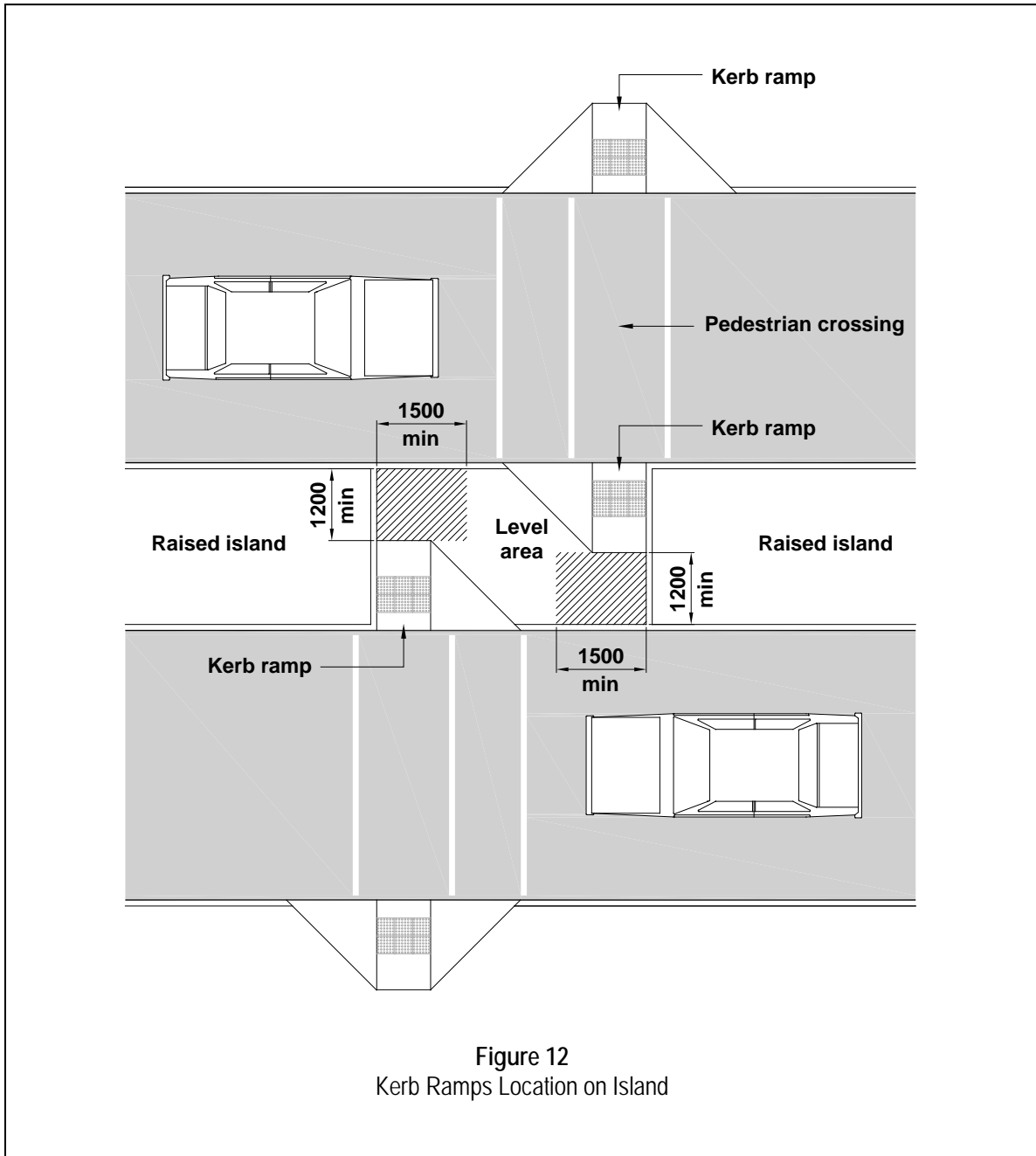

Figure 12
Kerb Ramps Location on Island

CHAPTER 4

ACCESSIBILITY AROUND AND WITHIN THE BUILDING

Objective : Access Around and Within the Building

The layout of the building shall allow persons with disabilities to travel around and within the building without assistance.

Horizontal Circulation

- | | | |
|---|--|--------|
| ▪ | Floor and Ground Surfaces | CI 4.1 |
| ▪ | Accessible routes, corridors and paths | CI 4.2 |
| ▪ | Headroom | CI 4.3 |
| ▪ | Doors | CI 4.4 |

Vertical Circulation

- | | | |
|---|--|---------|
| ▪ | Changes in Levels | CI 4.5 |
| ▪ | Ramps | CI 4.6 |
| ▪ | Handrails and Grab bars | CI 4.7 |
| ▪ | Passenger Lifts | CI 4.8 |
| ▪ | Lifts Designated for Wheelchair Users | CI 4.9 |
| ▪ | Platform Lifts and Wheelchair Stairlifts | CI 4.10 |
| ▪ | Stairs | CI 4.11 |
| ▪ | Stairs for Ambulant Disabled | CI 4.12 |

4.1 FLOOR AND GROUND SURFACES

Floor and
ground
surfaces

4.1.1 General

4.1.1.1 Floor surfaces shall:

- (a) be stable, firm, level and slip-resistant;
- (b) not have any drop or unexpected variations in levels;
- (c) contrast with the walls in tone and colour, otherwise the skirting must provide a clear distinction between the floor and wall; and
- (d) where there is a change in level, contrasting colour bands and detectable warning surfaces are to be provided to alert users of the change in level complying with clause 4.5.

Note: (1) *Where carpets or carpet tiles are used in general circulation areas, they should:*

- (i) *be securely fixed;*

- (ii) *have a firm cushion, pad or backing; and*
- (iii) *have exposed edges fastened to floor surfaces with trim complying with Table 4.*

- (2) *Information on slip resistance of floor finishes is given in Appendix F.*
- (3) *All floor finishes exposed to elements under the wet condition shall be in accordance with the current edition of SS 485.*
- (4) *Highly polished or reflective surfaces should be avoided as they can cause glare. This will cause discomfort for persons with visual impairment.*

4.1.2 **Gratings and gaps along the accessible route**

Gratings

4.1.2.1 If gratings are located on accessible routes, gratings as illustrated in Figure 13 shall:

- (a) be set flush with the surrounding surface; and
- (b) have spaces / gaps / openings not greater than 12 mm wide;

- Note:
- (1) *Where possible, gratings should be located outside the accessible route.*
 - (2) *Gratings should be placed so that the long dimension is perpendicular to the dominant direction of travel.*

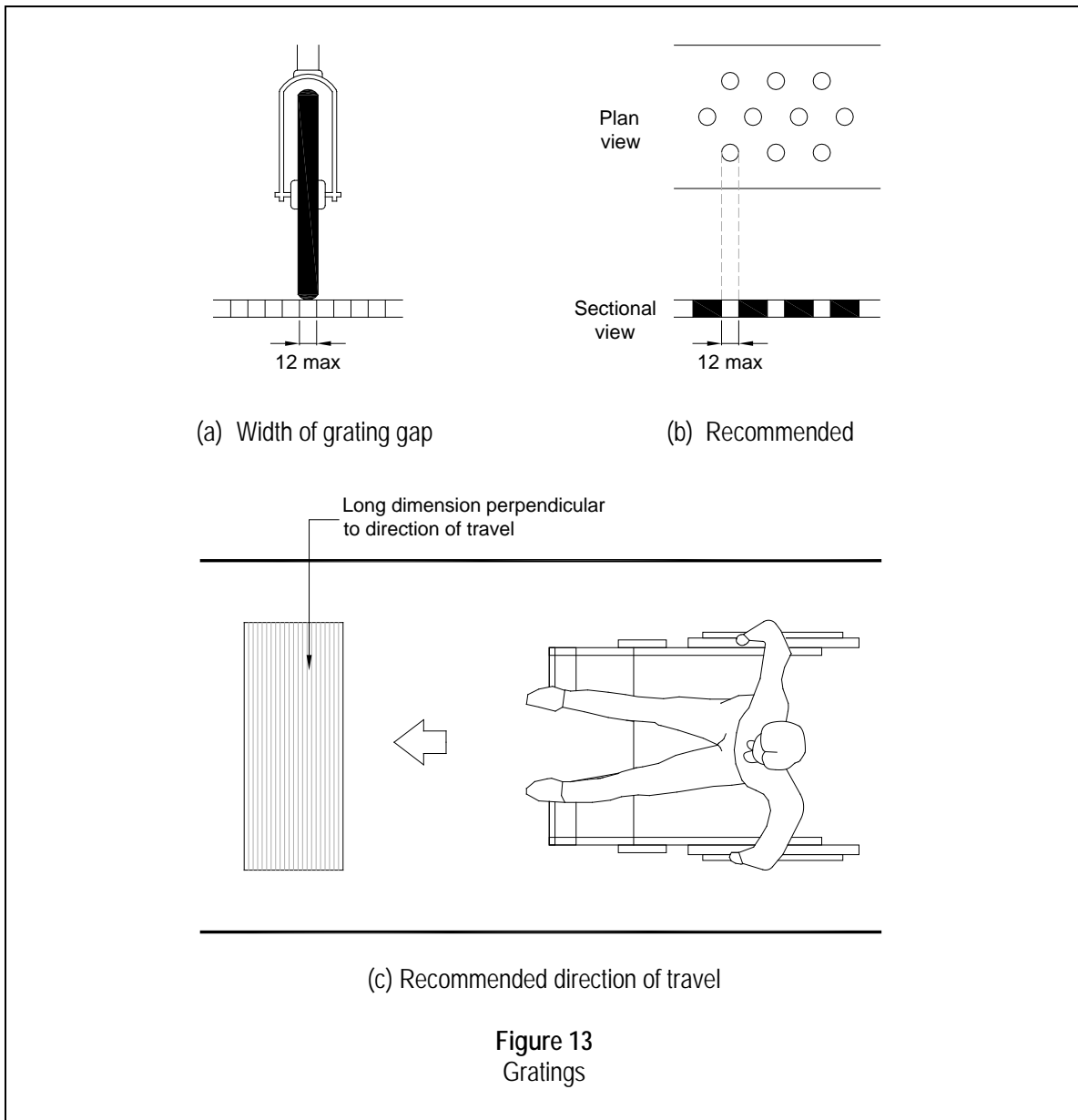

4.2 ACCESSIBLE ROUTES, CORRIDORS AND PATHS

Accessible routes

4.2.1 Width

4.2.1.1 The minimum width of the accessible routes, corridors and paths shall be:

- (a) as prescribed in Table 3 for the primary access routes of the building types; and
- (b) at least 1200 mm for :
 - (i) secondary access routes; and
 - (ii) all other building types that are not listed in Table 3.

TABLE 3
Accessible Route Widths

Building Type	Minimum width of accessible route
Residential developments, hotels, boarding houses, service apartments, workers' dormitories, hostels, halls of residence or dormitories etc. Schools, office buildings Factories, workshops, industrial buildings and offices/showroom areas in warehouses	1500 mm
Universities, colleges and similar institutions of learning Parks, open spaces and places of public resort Sport complexes and public swimming pools MRT stations and bus interchanges and passenger terminals Shopping centres and multi-purpose complexes Markets, hawker or food centres, restaurants and eating establishments Hospitals, nursing homes, welfare homes and homes for the aged	1800 mm

4.2.1.2 Where width of accessible routes, corridors or paths are less than 1800 mm, at least one passing space with the minimum width of 1800 mm and length of 1800 mm as shown in Figure 14 shall be provided as follows:

- (a) for accessible routes of parks and open spaces at intervals of not more than 50 m;

- (b) for all other accessible routes and corridors, at intervals of not more than 25 m.

Note: *For existing buildings undergoing additions and alterations with exceptional circumstances and particular constraints, corridor width of 1200 mm may be considered with the provision of passing space.*

- 4.2.1.3 Within office work areas, the minimum width for accessible routes shall be at least 900 mm.
- 4.2.1.4 An accessible checkout lane shall be at least 900 mm as shown in Figure 15.
- 4.2.1.5 Manoeuvring space as described in clause 4.4.6 shall be provided at doorways.
- 4.2.1.6 A turning space of at least 2000 mm in the direction of travel and not less than 1500 mm wide shall be provided at a dead-end corridor as shown in Figure 14 to allow wheelchair users to turn 180° and return in the other direction.

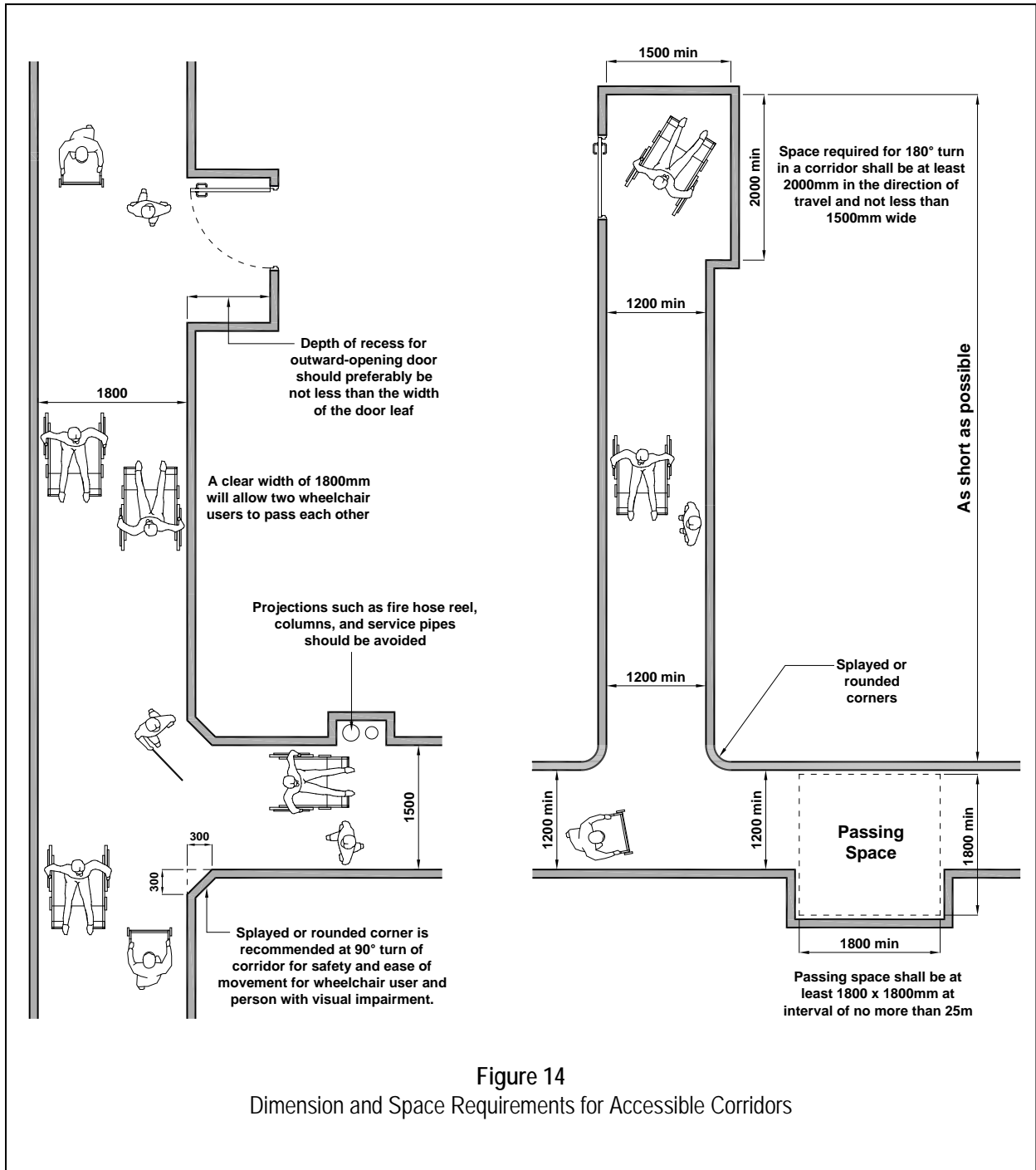
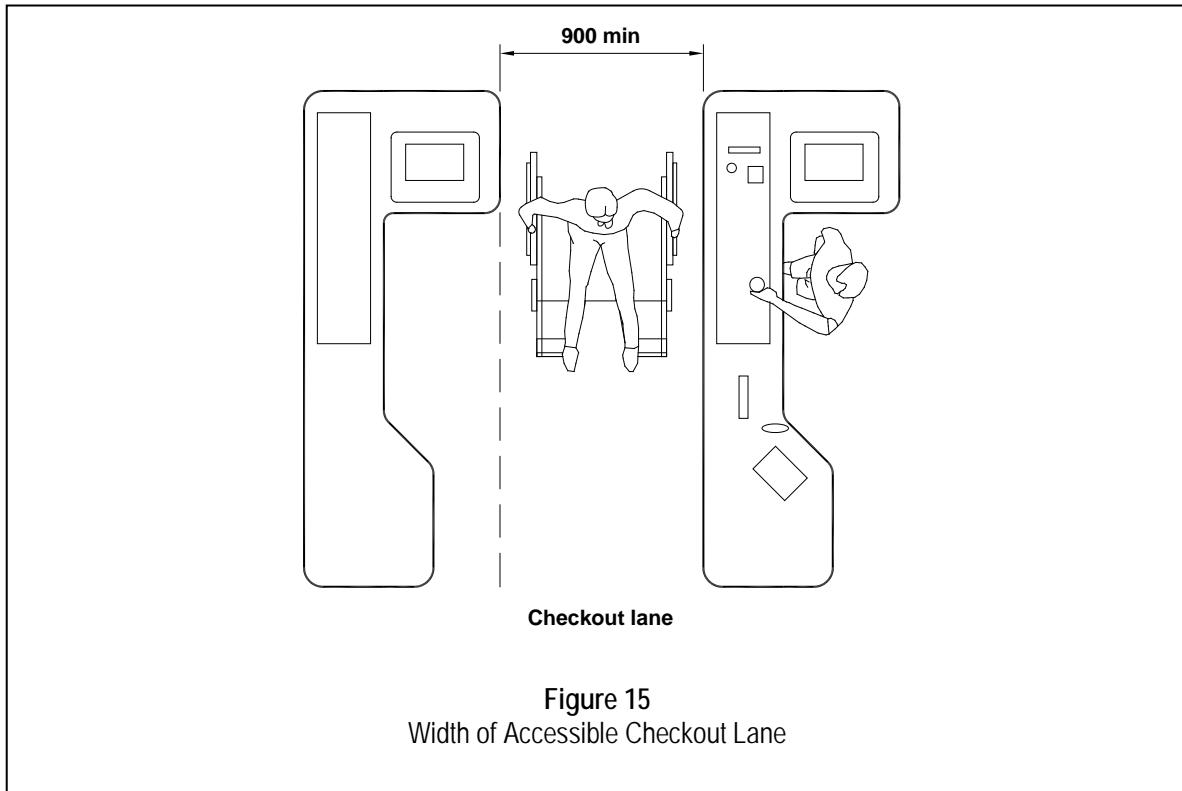

Figure 14
Dimension and Space Requirements for Accessible Corridors



4.2.2 Turnstiles

Turnstiles

4.2.2.1 An accessible gate with a width of 850 mm or more shall be provided beside a turnstile as shown in Figure 16.

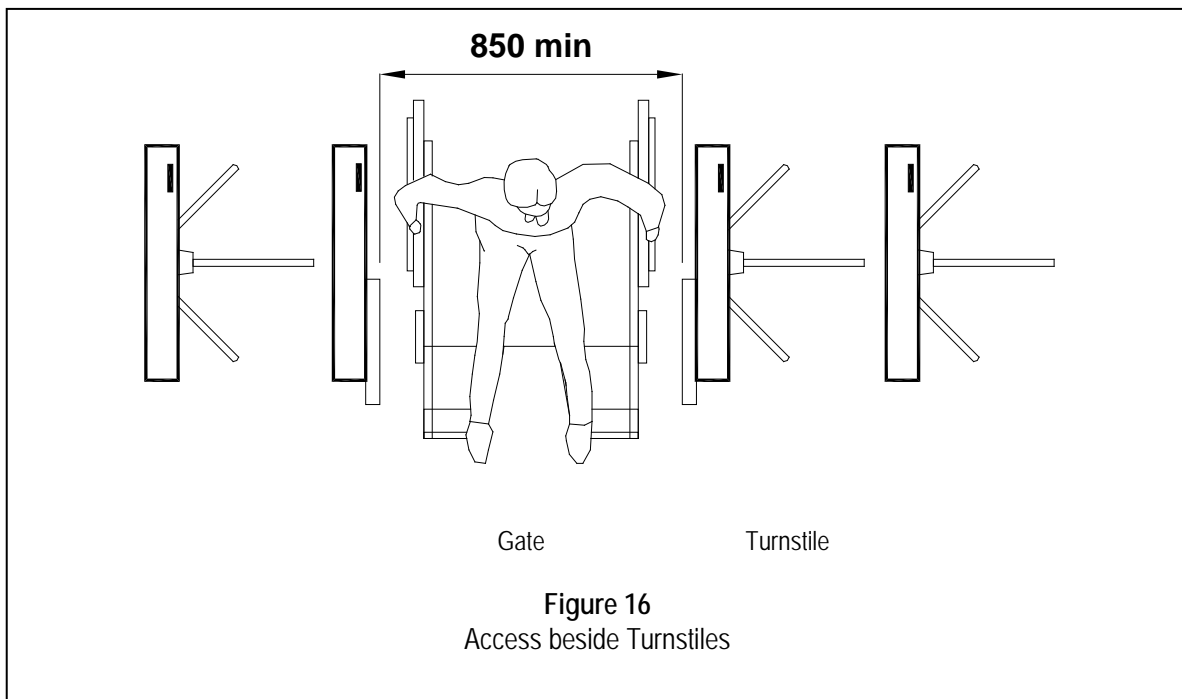

4.2.3 **Walls**

Walls

4.2.3.1 The corners of walls should not have sharp edges.

4.2.3.2 The wall finish shall be smooth or, in the case of rough walls, have trailing bars or handrails placed at a height of 840 mm from the floor level as illustrated in Figure 17 so that persons with visual impairment can trail along it without hurting their hands.

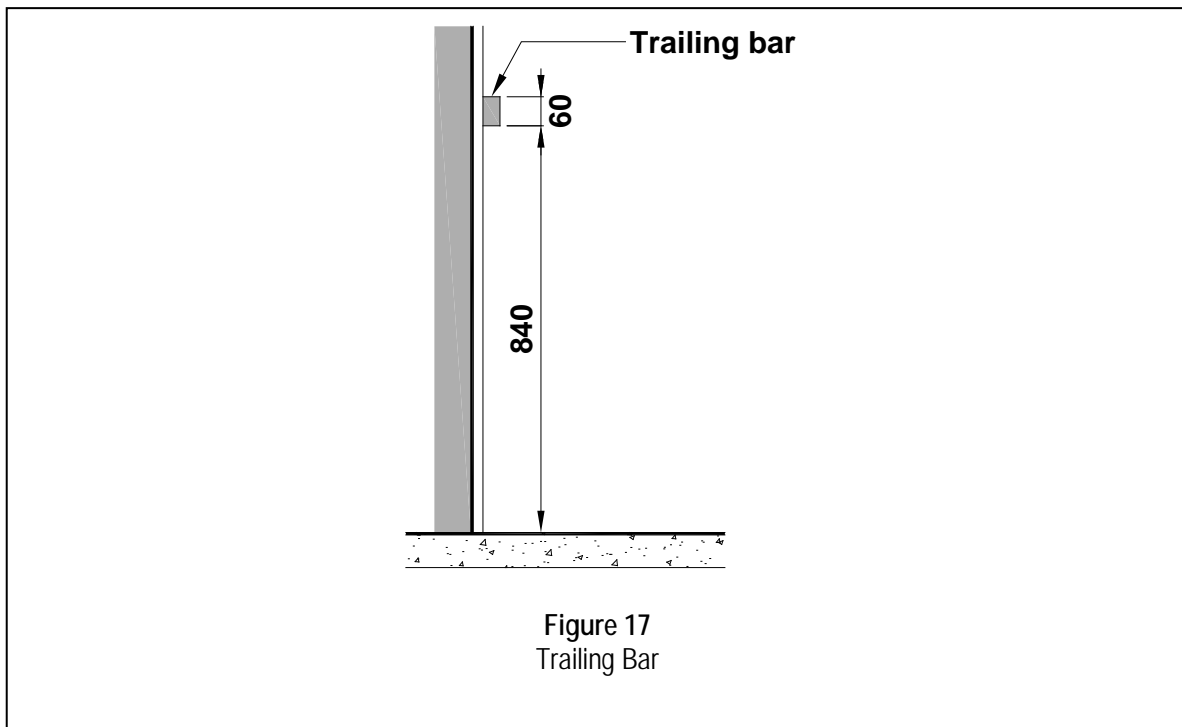
4.2.4 **Protruding Objects**

Protruding objects

4.2.4.1 **General**

4.2.4.1.1 Obstacles, projections or other protrusions shall be avoided in pedestrian areas such as walkways, halls, corridors, passageways or aisles.

4.2.4.1.2 Protruding objects, if any, shall not reduce the clear width required for an accessible route or manoeuvring space.

4.2.4.2 **Undetectable objects attached to a wall**

4.2.4.2.1 Objects or obstructions, with their leading edges at any height above 580 mm from the floor level shall not protrude more than 100 mm into pedestrian areas as illustrated in Figure 18 (a).

Note: *Where a person with visual impairment is walking alongside protruding objects, they cannot detect overhangs. Where the person is using the wall or an edge as a guide, a protrusion of not more than 100 mm is acceptable.*

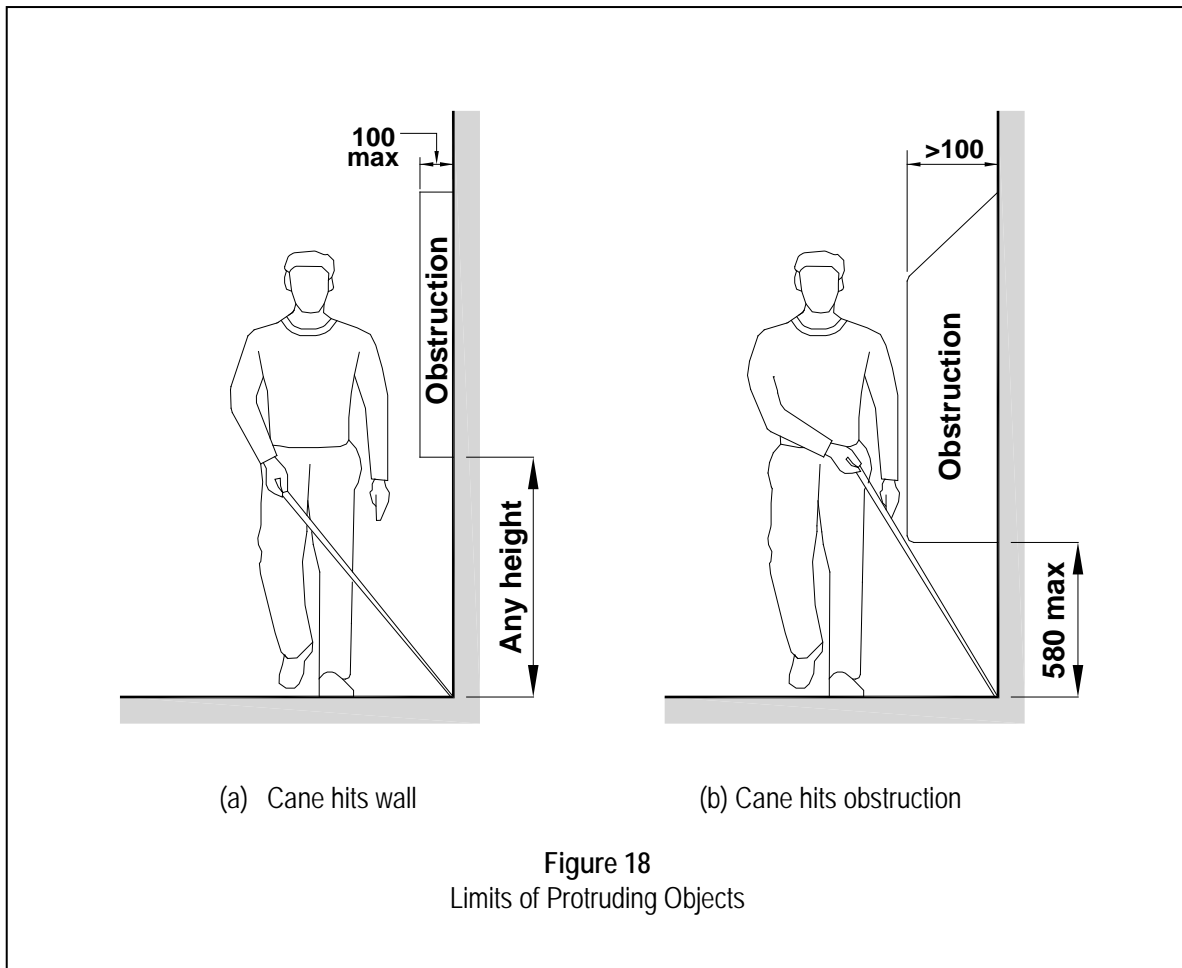

4.2.4.3 Detectable objects attached to a wall

4.2.4.3.1 Objects or obstructions, with their leading edges up to a maximum height of 580 mm from the floor level, may protrude more than 100 mm into pedestrian areas as illustrated in Figure 18 (b).

Note: *Potentially hazardous objects or obstructions are noticed only if they are within the detection range of white canes. Persons with visual impairments, walking towards an object or obstruction can detect an overhang if its lowest surface (leading edge) is 580 mm or less from the floor level.*

4.2.4.4 Free standing objects

4.2.4.4.1 Free standing objects placed between the height of 580 mm and 2000 mm from the floor level shall have an overhang of 300 mm or less as illustrated in Figure 19 (a).

4.2.4.4.2 The maximum height of the bottom edge of freestanding objects with a space of more than 300 mm between supports shall be 580 mm or less from the floor level as illustrated in Figure 19 (b).

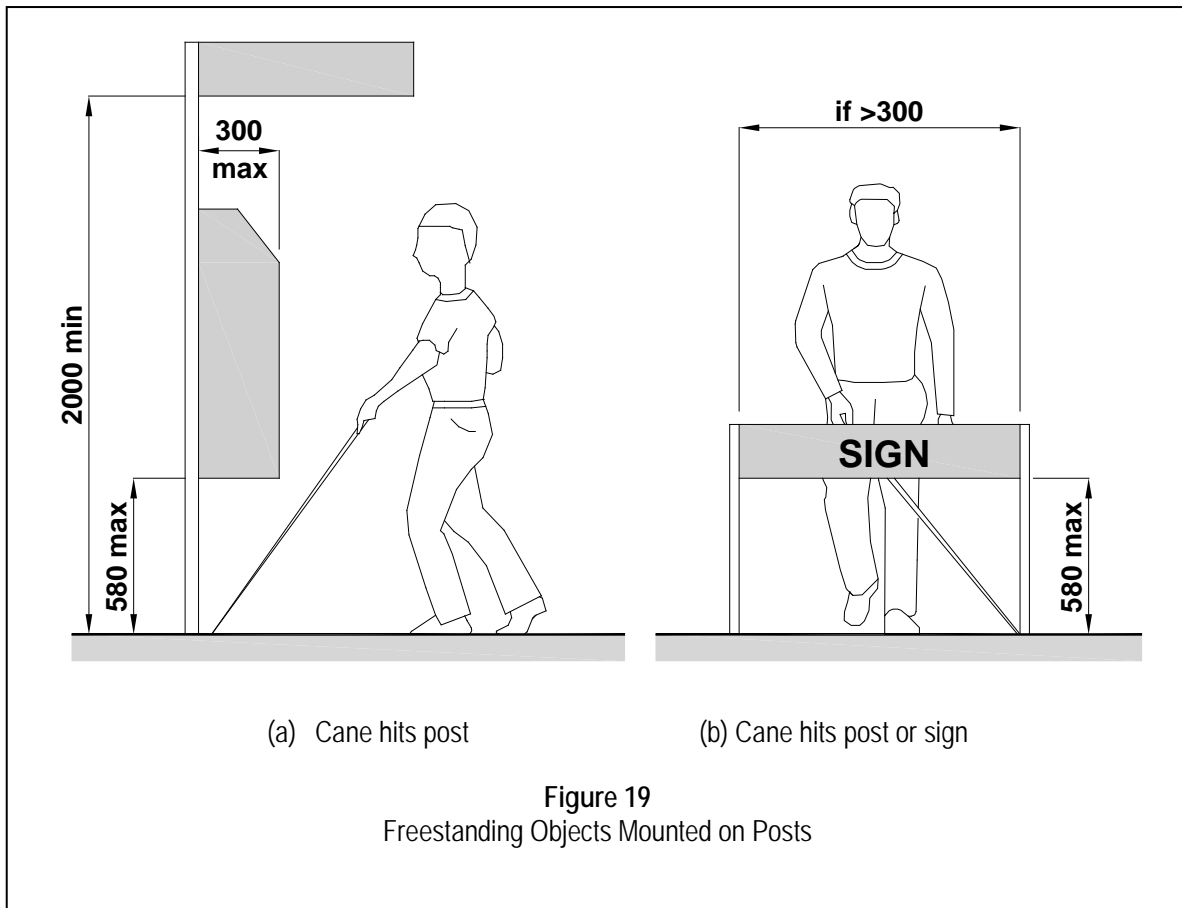

4.2.4.5 Bollards

Bollards

4.2.4.5.1 Where bollards are erected at entrances to walkways or pathways they shall:

- (a) have a minimum clear distance of 900 mm between the bollards;
- (b) not be linked with a chain or rope;
- (c) have a minimum height of 800 mm;
- (d) have a colour which contrasts with the background or be provided with a coloured or reflected band around the neck of the bollard to further aid visibility;
- (e) not have ornamental features protruding horizontally; and
- (f) be well lit and the light fitting should be positioned in such a manner that will not cause glare.

4.2.5 Resting areas

Resting areas

4.2.5.1 Resting areas with seats shall be provided along long paths of travel. Long paths of travel should be avoided and resting areas shall be provided at frequent intervals not exceeding 50 m.

4.2.5.2 Where seats are provided, they should have armrests to assist older persons or persons with disabilities to get up from the seats. The height of seat should be between 430 mm to 470 mm.

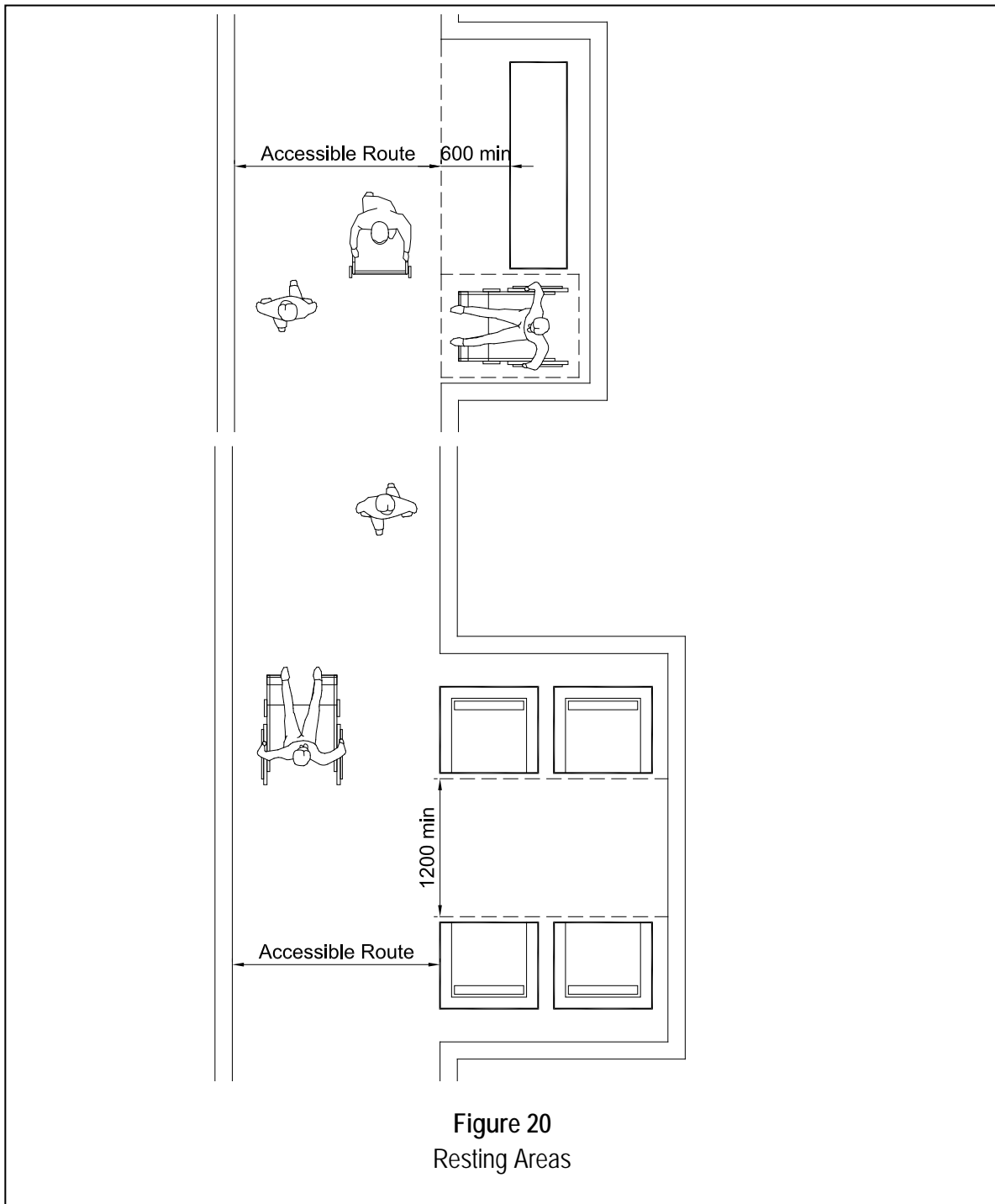

Figure 20
Resting Areas

Note: *Resting areas should be recessed from the long paths of travel which can also act as a passing space for two wheelchair users to pass each other as illustrated in Figure 20.*

4.2.6 **Exterior walkways**

Exterior walkways

4.2.6.1 Wherever possible, exterior walkways should be protected from the elements.

4.3 **HEADROOM**

Headroom

4.3.1 **General**

4.3.1.1 The minimum clear headroom in pedestrian areas such as walkways, halls, corridors, passageways or aisles shall be 2000 mm.

4.3.2 **Overhead hazard**

4.3.2.1 A detectable guardrail or other barrier having its leading edge at or below 580 mm from the floor level shall be provided where the headroom of an area adjoining an accessible route is reduced to less than 2000 mm as illustrated in Figure 21.

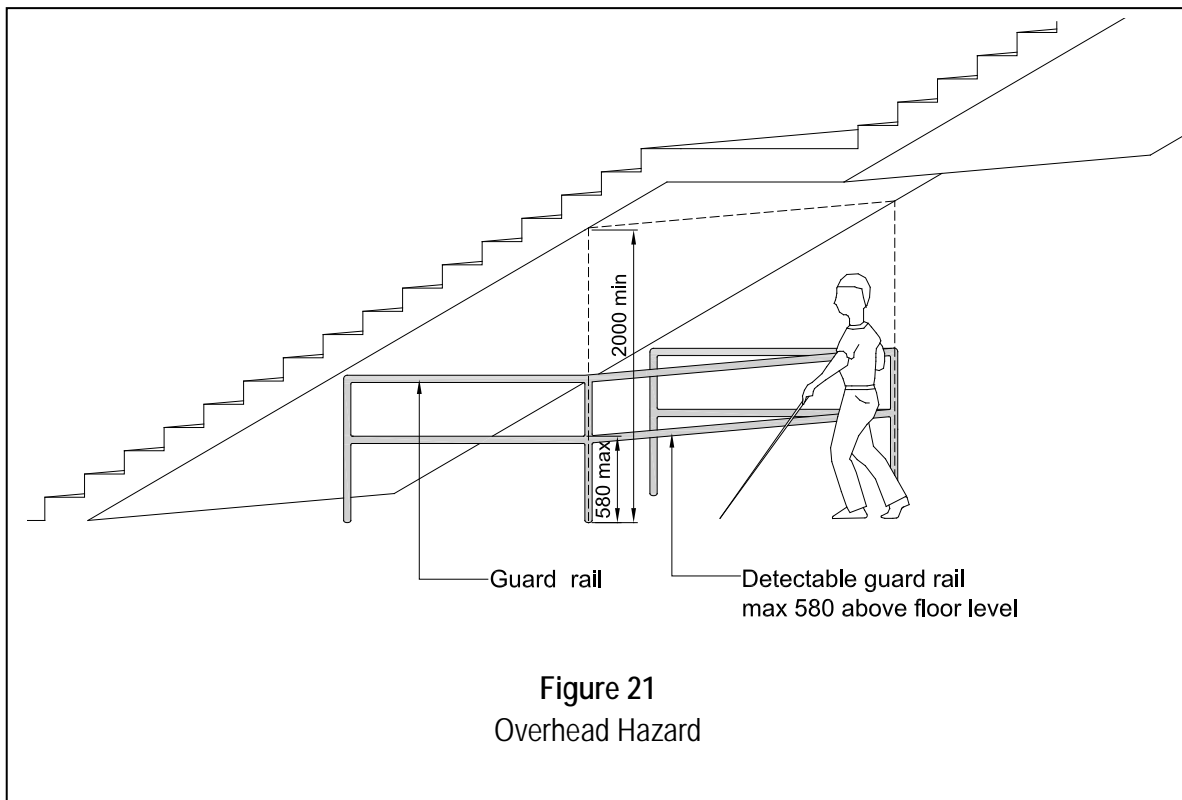

Note: *The requirement to have an area free from obstruction is primarily to aid persons with visual impairments as shown in Figures 18, 19 and 21. Examples of such obstructions are directional signs, firefighting equipment and the underside of staircases or escalators.*

4.4	DOORS	Doors
4.4.1	General	
4.4.1.1	Doorways shall be level.	
4.4.1.2	At least one power-operated or automatic door should be provided at the main entrance to a building.	
4.4.1.3	Wherever possible and practicable, automatic doors (sliding or swing type) should be provided instead of doors that are manually opened. Heavy or revolving doors should be avoided.	
4.4.1.4	Automatic doors, if provided should have a return delay mechanism to give adequate time for safe passage and for detecting the presence of a person lying on the floor within the door closing area. The door should also be capable of manual operation should there be a power failure.	
4.4.1.5	Where power-operated doors are provided, it shall be in accordance with the requirements of clause 4.4 and 6.2.	
4.4.1.6	Where revolving doors are installed, there shall be an auxiliary side-hung door with a minimum clear opening of 850 mm.	
4.4.1.7	The colour of the door shall contrast with the door frame or the wall.	
4.4.1.8	Where doors are numbered, the digits should be in accordance with the requirements of clause 8.5.1.2 and Table 7.	
4.4.2	Clear opening	Clear Opening
4.4.2.1	The minimum clear opening of doorways shall be 850 mm measured between the face of the door and the face of the doorstop with the door open at 90° as illustrated in Figure 22.	

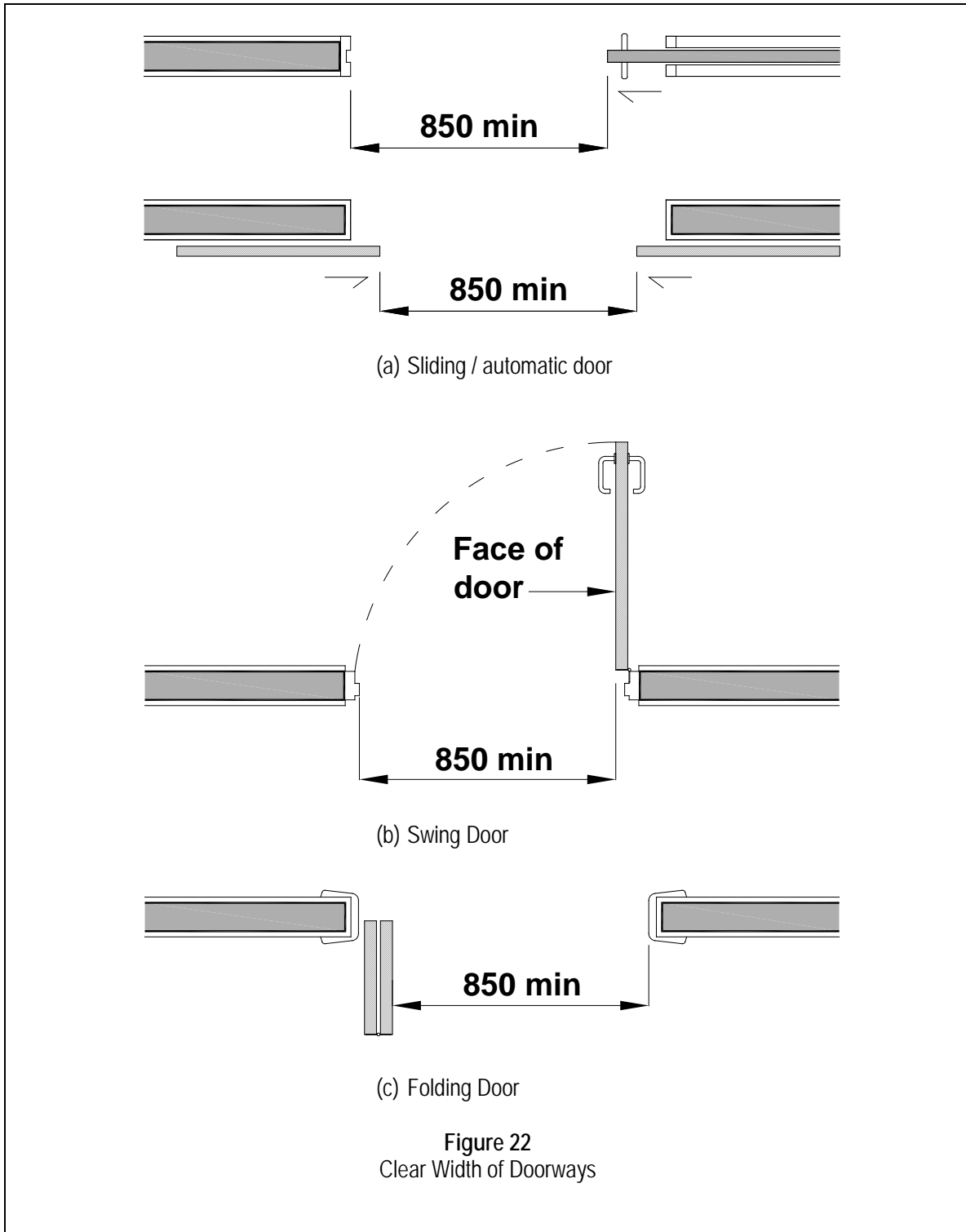

Note: *Automatic doors should be capable of manual operation and should be able to remain totally open without support in the event of emergency.*

4.4.3 Double-leaf doorways

4.4.3.1 If doorways have two independently operated door leaves, at least one active leaf shall comply with clauses 4.4.2 and 4.4.6.

- 4.4.4 **Sliding/folding doors** Sliding / folding doors
- 4.4.4.1 Where manually operated sliding/folding doors are used, operating hardware shall be exposed and have a sufficient gripping surface area from both sides when sliding/folding doors are fully open.
- 4.4.4.2 Accessible handles on the exposed edge of manually operated sliding doors shall be in accordance with clause 4.4.9.2 as shown in Figure 28 (d).
- 4.4.4.3 Where power-operated sliding/folding doors are used, it shall be in accordance with clause 4.4 and 6.2.
- Note: *Wherever possible and practicable for accessible toilets, power-operated sliding door with button control should be provided instead of manually operated sliding doors.*
- 4.4.5 **Glass doors** Glass doors
- 4.4.5.1 Unframed full-height glass doors shall be prominently marked or highlighted with motifs to make them visible.
- 4.4.5.2 The markings or motifs shall consist of two horizontal bands, each at least 100 mm high and of contrasting colours to assist visibility.
- 4.4.5.3 The upper band shall be affixed at a height between 1400 mm and 1600 mm and the lower band affixed at a height between 850 mm and 1000 mm above the floor level. Where each band zone consists of more than one band, the aggregate width of the bands in each zone shall be 100 mm or more as shown in Figure 23.

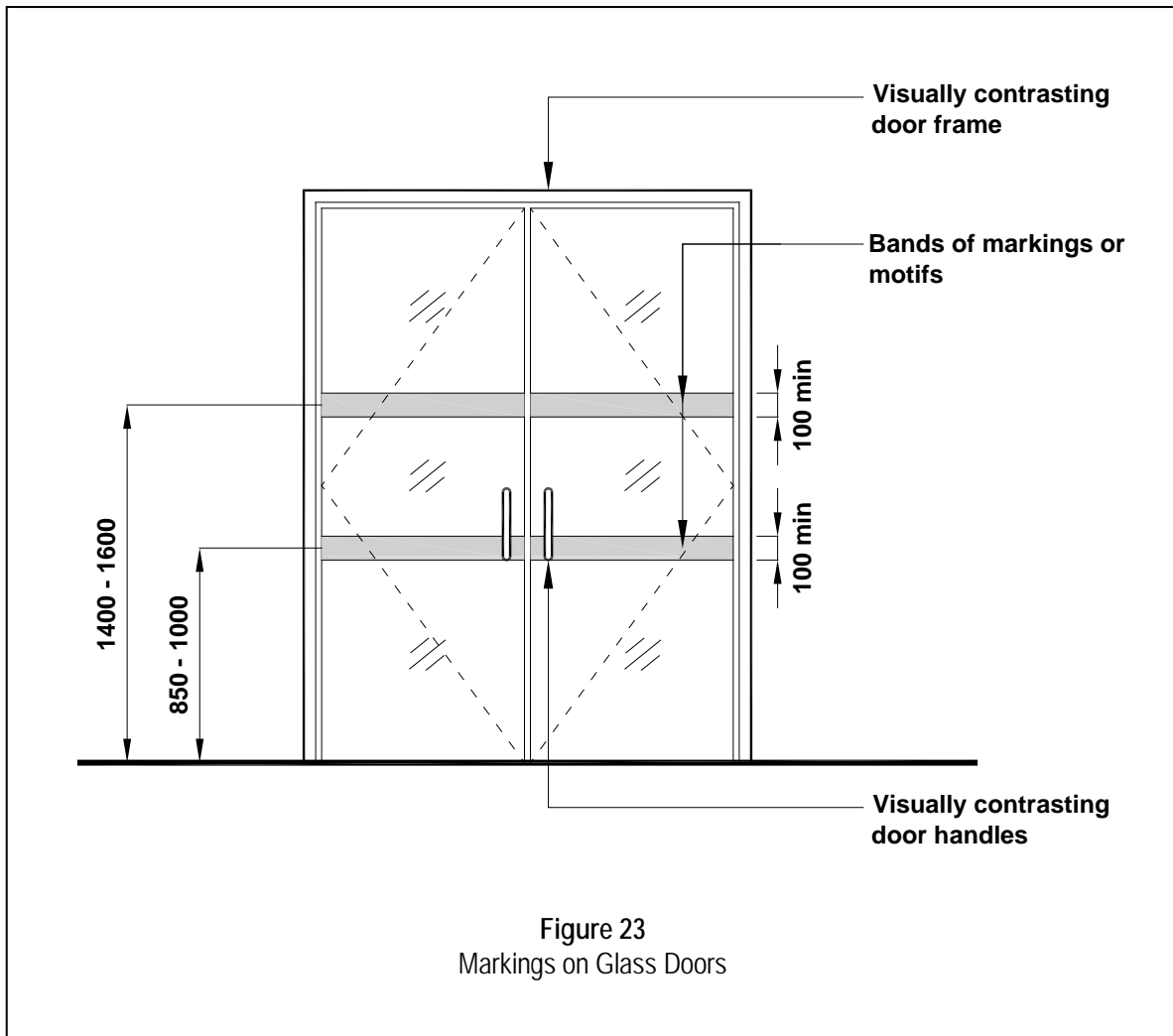

4.4.6 Manoeuvring spaces at doors

Manoeuvring spaces

4.4.6.1 Except for power-operated doors, the doorway of a one-way swing door shall have manoeuvring spaces on both sides for wheelchairs and the following clear spaces shall be provided, adjacent to the leading edge of the door as illustrated in Figure 24:

- (a) on the pull side, a minimum space of 600 mm adjacent to the leading edge of the door with a minimum clear floor space of 1500 mm wide by 1500 mm deep; and
- (b) on the push side, a minimum space of 300 mm adjacent to the leading edge of the door with a minimum clear floor space of 1200 mm wide by 1200 mm deep.

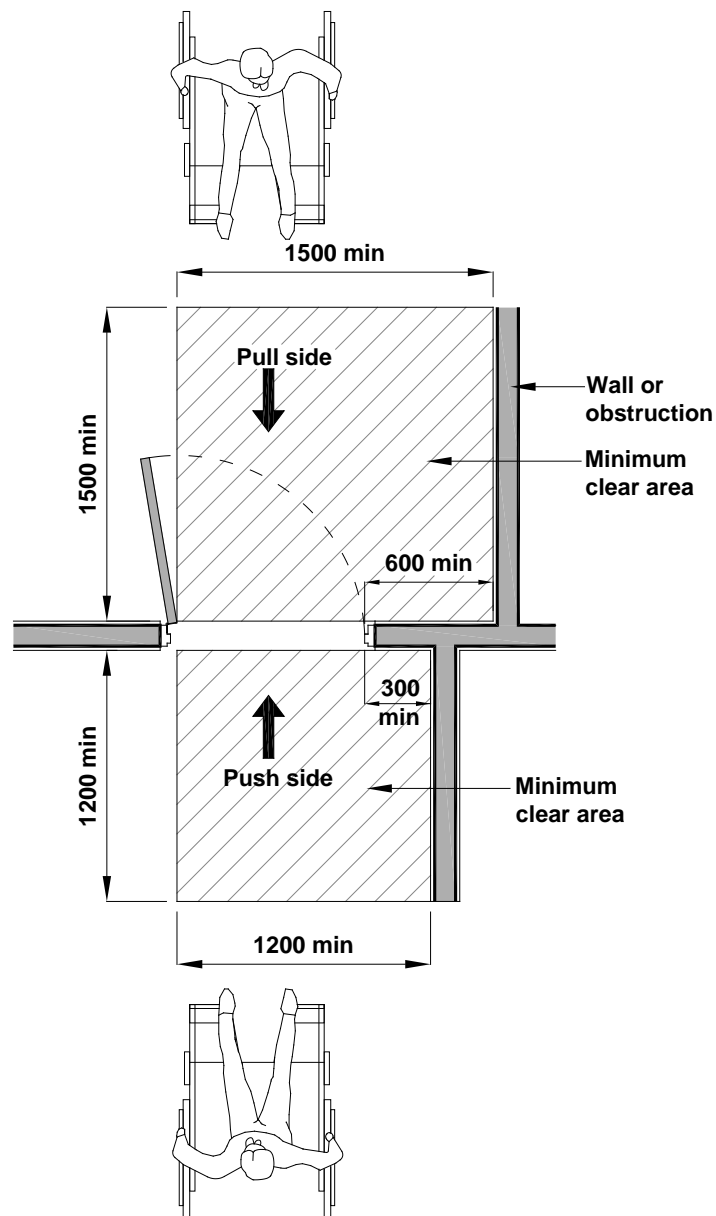

Figure 24
Minimum Doorway Manoeuvring Space

- 4.4.6.2 Where two-way swing doors or sliding doors are used as illustrated in Figure 25, a minimum space of 300 mm adjacent to the leading edge of the door with a minimum clear floor space of 1200 mm wide by 1200 mm deep shall be provided on each side of the door.

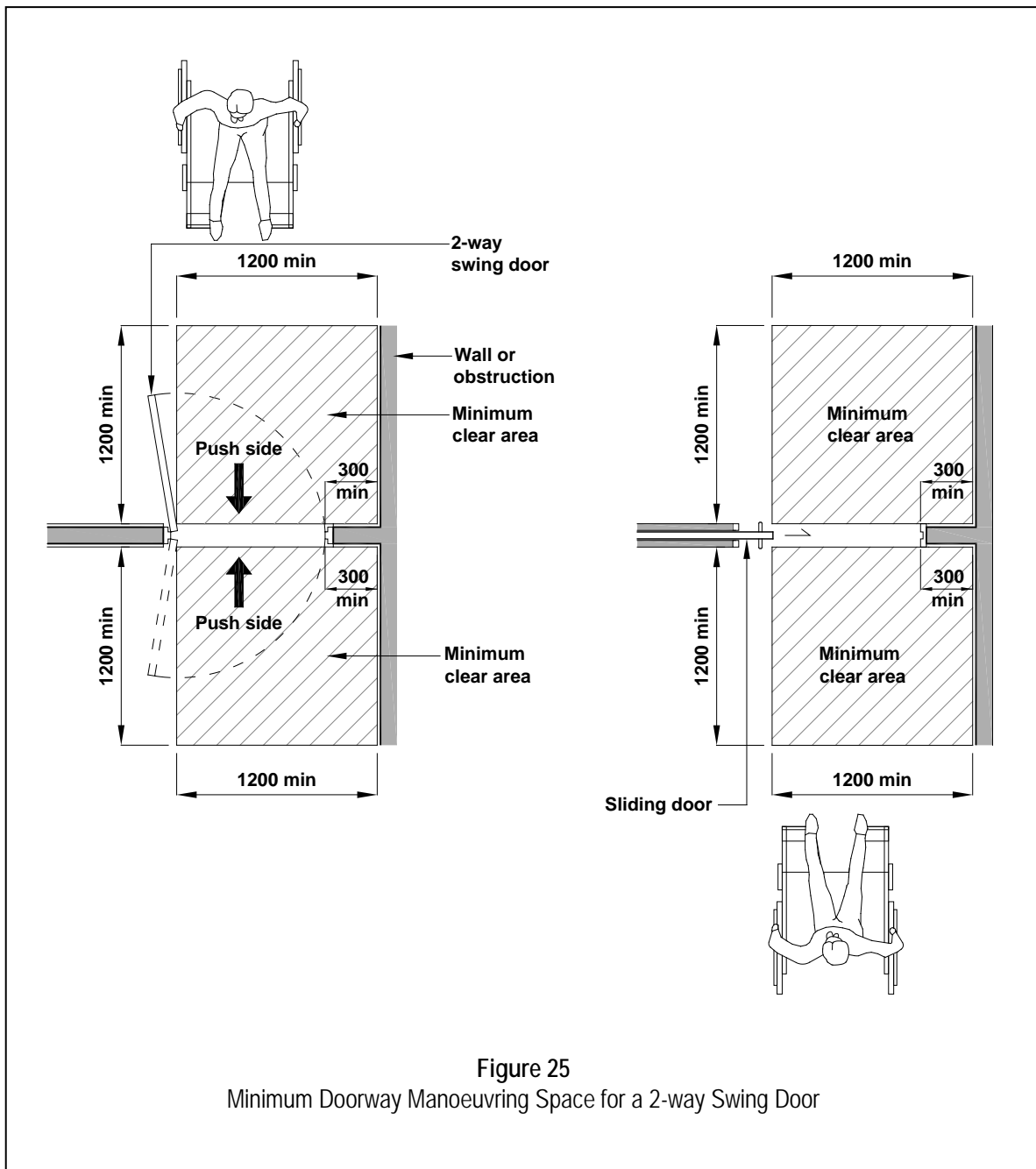

Figure 25
Minimum Doorway Manoeuvring Space for a 2-way Swing Door

4.4.6.3 The leading edge of the door leaf shall not be set more than 150 mm away from the wall surface as shown in Figure 26.

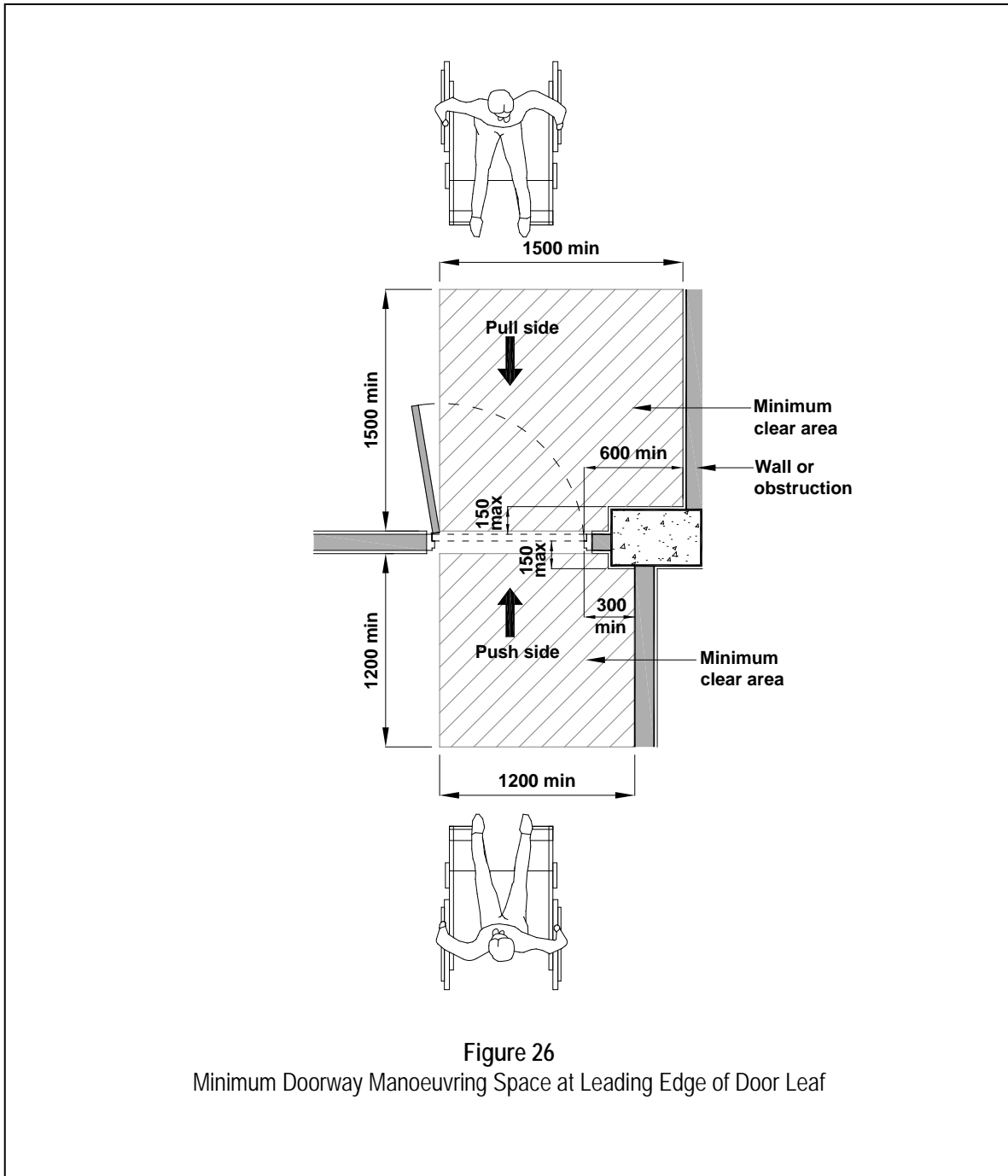
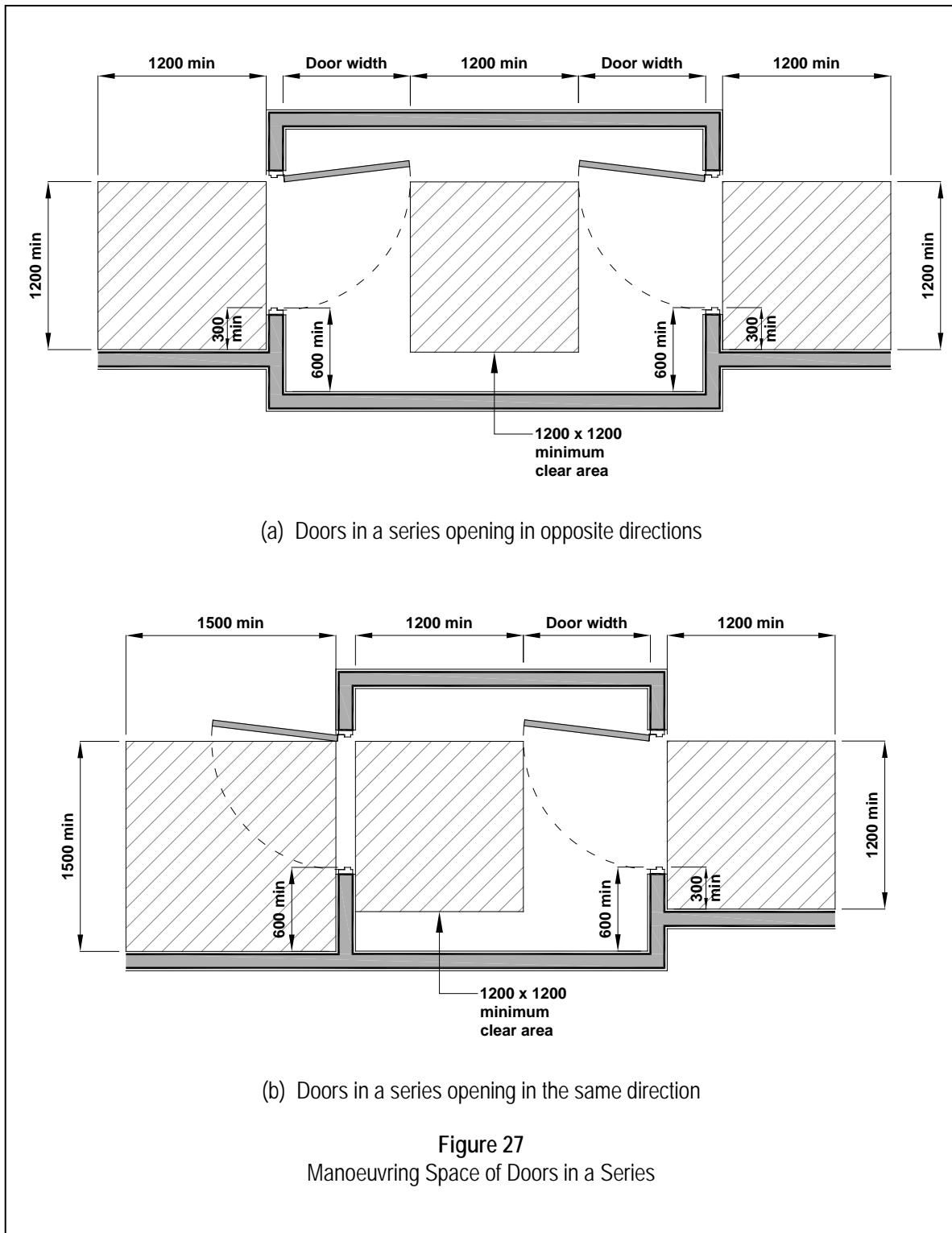

Figure 26
Minimum Doorway Manoeuvring Space at Leading Edge of Door Leaf

4.4.7 Two doors in a series

Two door in a series

4.4.7.1 The minimum space between two hinged doors or pivoted doors in a series shall be 1200 mm plus the width of the door swinging into that space as illustrated in Figure 27.



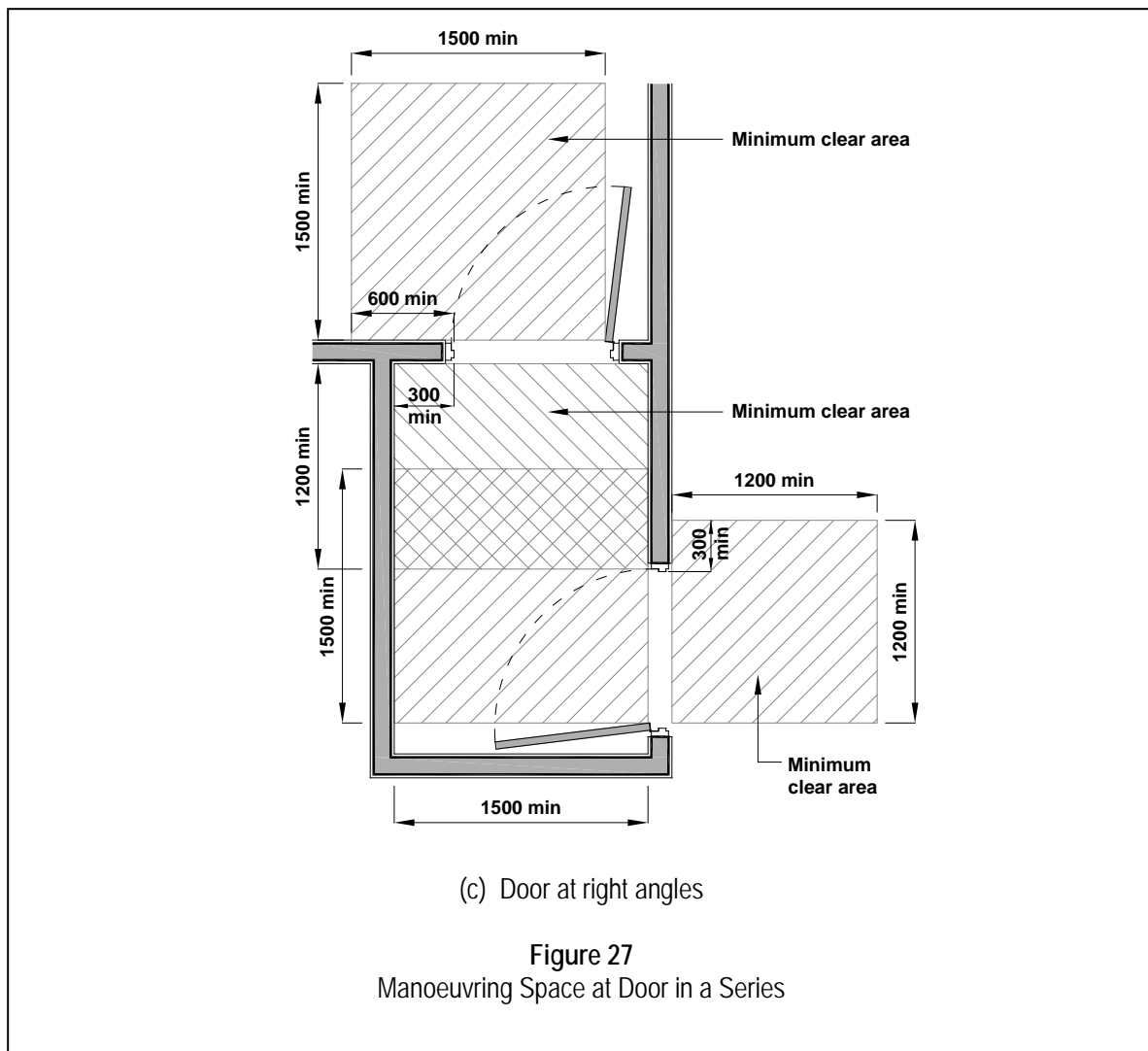

4.4.8 Door hardware

Door hardware

4.4.8.1 Operating devices such as handles, pulls, latches and locks shall:

- (a) be operable by one hand;
- (b) not require fine finger control, tight grasping, pinching or twisting of the wrist to operate; and
- (c) be mounted at a height of 900 mm to 1100 mm from the floor.

4.4.8.2 Door hardware and doorbells should have colours that contrast with the background.

4.4.9 Door handles Door handles

4.4.9.1 Door handles, as illustrated in Figure 28, with the following characteristics are recommended:

- (a) push-pull mechanisms that do not require grasping;
- (b) lever handles should be used on latched doors;
- (c) door handles that reduce the risk of injury from the exposed lever's end as well as reduced risk of catching on clothing; and
 - (i) Hand grip zones at least 100 mm in length;
 - (ii) Lever handles should be min 19 mm in diameter;
 - (iii) Hand grip zones at least 45 mm from faces of doors;
- (d) should contrast with the colour of the door.

4.4.9.2 Door handles for sliding doors as shown in Figure 28 (d) shall comply with clause 4.4.9.1 (c) and the following:

- (a) be a vertical bar handle;
- (b) length of handle to be at least 140 mm; and
- (c) installed between 60 mm to 130 mm from the door jamb or doorstop when in open or closed positions.

Note: (1) *Door knobs are not recommended as they do not provide adequate grips for persons with impaired hand functions.*

(2) *Door handles should be at a consistent height throughout the building.*

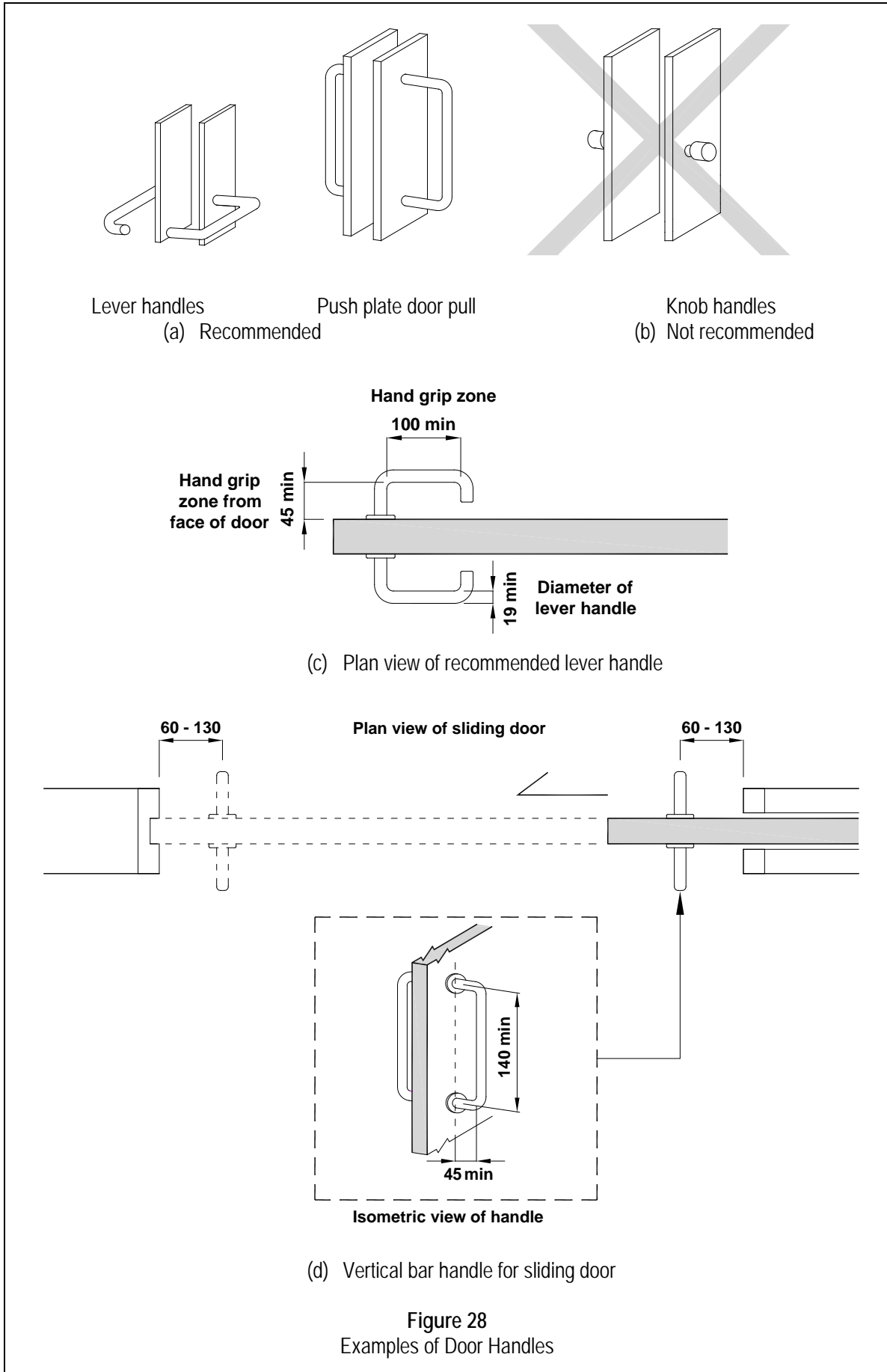

Figure 28
Examples of Door Handles

4.4.10 Door opening force

Door opening force

4.4.10.1 The force, measured at the leading edge of the door to operate hinged doors, as illustrated in Figure 29, shall not be more than:

(a) 30N at 0°; and

(b) 20N at 30°

4.4.10.2 The maximum force required to operate sliding or folding doors should be 22N.

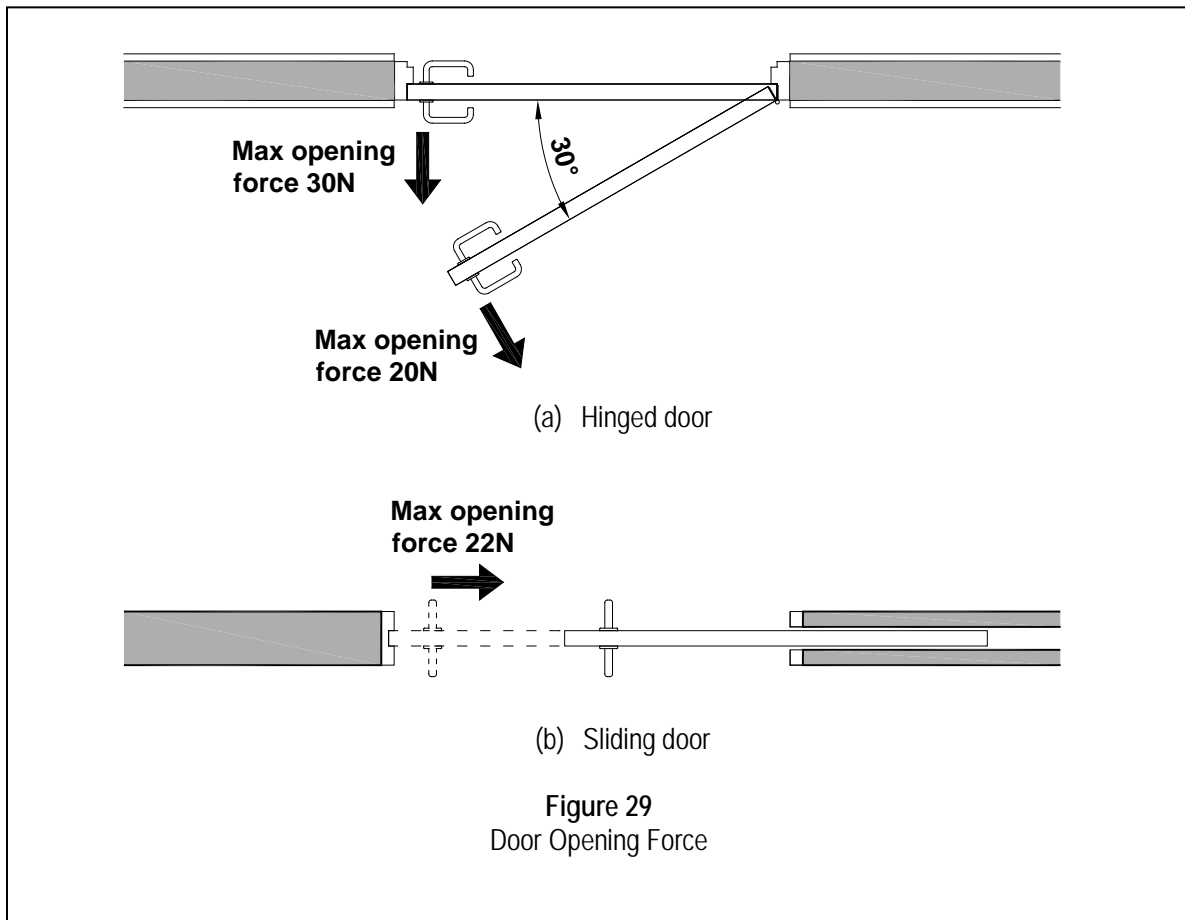

Note: *This clause does not apply to the force required to retract latch bolts or disengage other devices that may hold the door in a closed position.*

4.4.11 Door closers

Door closers

4.4.11.1 The sweep period of the door should be adjusted so that from an open position of 90° the door will take 3 seconds or more to move into a semi-closed position of approximately 12°.

Note: *Door closers with adjustable tension are recommended for this purpose so that the tension can be adjusted to comply with clause 4.4.10.*

4.4.12 Vision Panels

Vision panels

4.4.12.1 All two-way swing doors or doors across circulation routes shall be provided with vision panels as shown in Figure 30 giving a minimum zone of visibility from a height of 900 mm to 1500 mm. Wherever possible, the vision panel should be enlarged to allow for both the ambulant disabled and wheelchair user to be seen or observed by a person on the opposite side in order to prevent him from being accidentally struck by the opening door.

4.4.12.2 The width of the vision panel shall be not less than 100 mm.

4.4.13 Kickplates

Kickplates

4.4.13.1 Kickplates of at least 250 mm high as shown in Figure 30 are recommended for doors in high-use areas to protect the push side of doors from damage caused by wheelchair foot-rests.

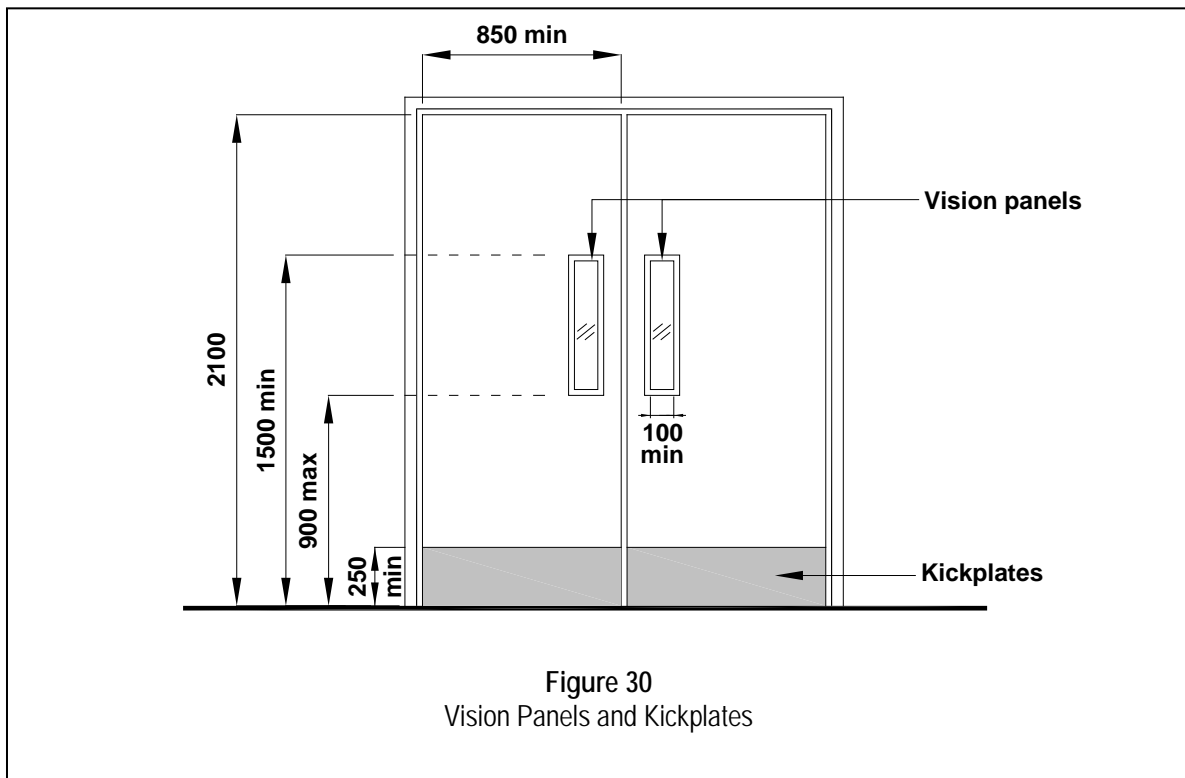

4.4.14 Guardrails (Out-swinging automatic door)

Guardrails

4.4.14.1 Where doors swing automatically into the path of travel, it is desirable to have guardrails, as shown in Figure 31:

- (a) extending at right angles to the wall containing the door; and
- (b) provided at a white cane detectable height of 580 mm or less.

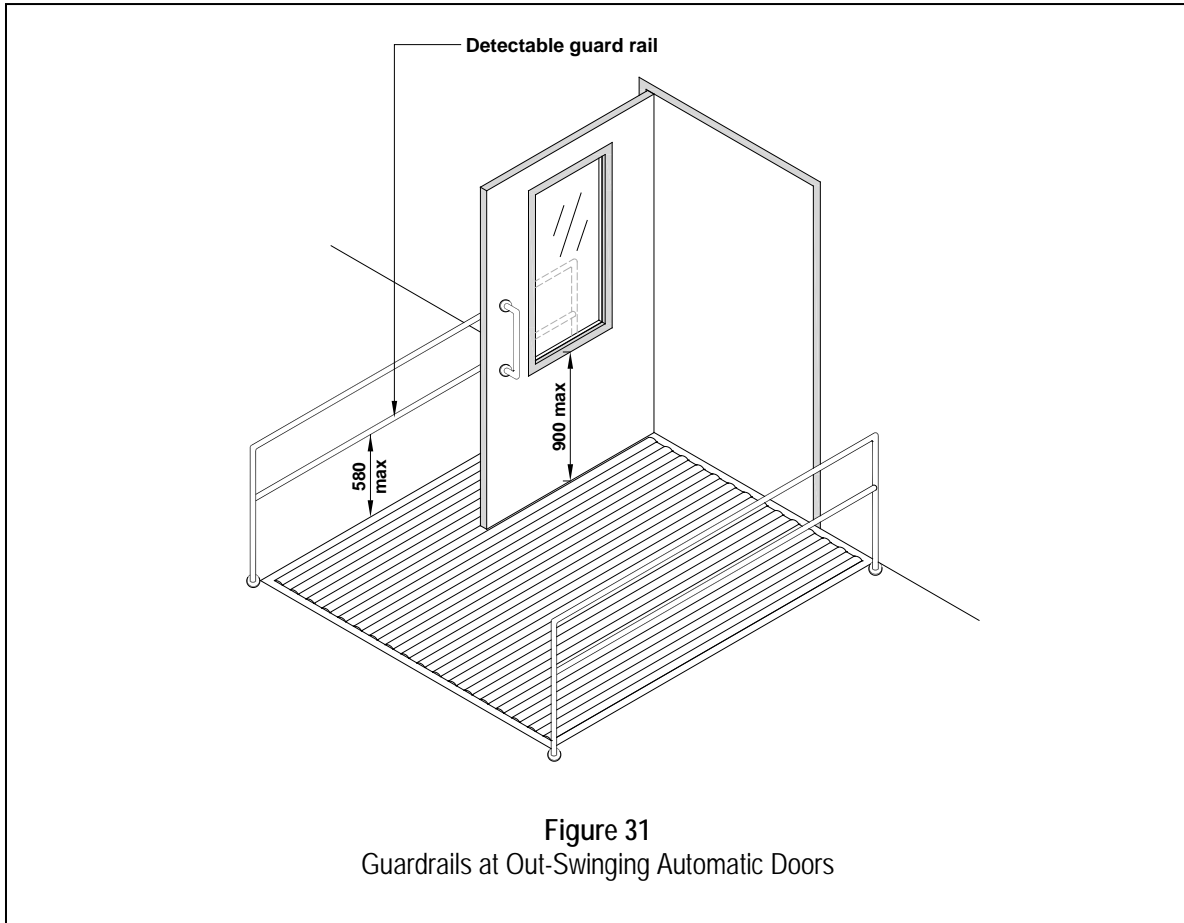

4.5 CHANGES IN LEVELS

Change in levels

4.5.1 Any change in level of the floor surface, the gradient of the slope shall conform to Table 4.

TABLE 4
Changes in Levels

Changes in Vertical Rise (mm)	Gradient not steeper than
0 to 15	1 : 2
more than 15 to 50	1 : 5
more than 50 to 200	1 : 10
Exceeding 200	1 : 12

4.5.2 Where the change in vertical rise is from 15 mm to 200 mm:

- (a) The ramp and landings shall be of contrasting colour; or

- (b) a coloured band shall be painted or marked across the top and bottom levels of the ramp or slope as shown in Figure 32 (a) so that the ramp or slope can be seen and clearly identified.

4.5.3 Where the rise is more than 200 mm, detectable warning surfaces at the top and bottom levels of the ramp or slope shall be provided. Detectable warning surfaces are not required at enclosed intermediate landings where handrails are continuous and which do not lead to another path of travel.

4.5.4 Detectable warning surfaces for ramps or slopes provided in accordance with clause 4.5.3 as shown in Figure 32 (b), shall:

- (a) extend across the full width of the ramp or slope for a depth of at least 300 mm;
- (b) set back 300 mm from the edge of the ramp or slope;
- (c) consist of flooring material that is:
 - (i) contrasting in colour with the surrounding flooring material; and
 - (ii) of a different texture from the surrounding flooring material.

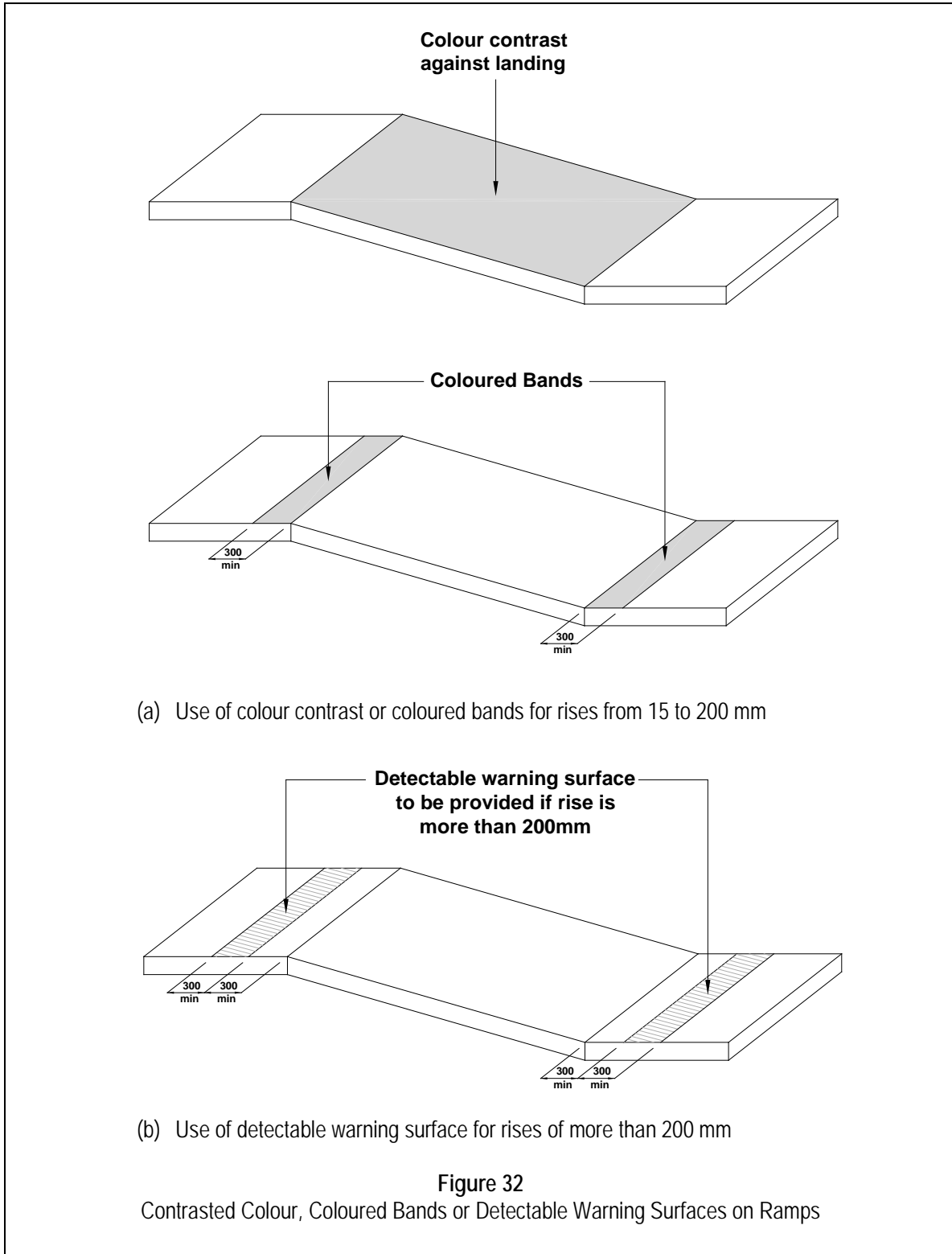

4.6 RAMPS

Ramps

4.6.1 General

4.6.1.1 Ramps allow wheelchair users to move from one level to another.

4.6.1.2 Where the horizontal run of an approach ramp exceeds 9.0 m in length, an alternative stepped approach as shown in Figure 33 (b), complying with the requirements in clause 4.11, in addition to the ramp approach, may be provided for the ambulant disabled. The total rise of any flight of steps shall not exceed 1200 mm.

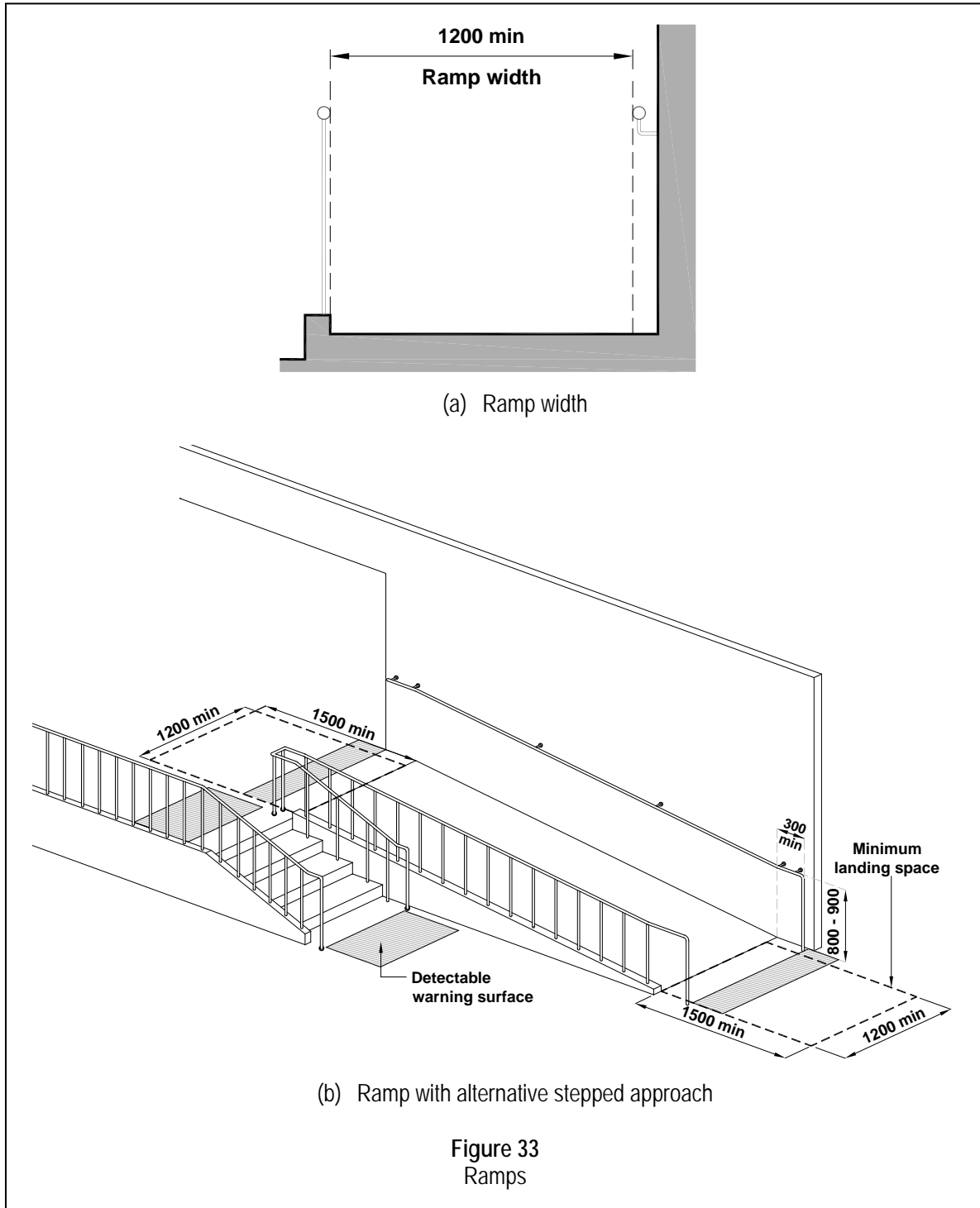

Note: (1) Ambulant disabled persons negotiate steps more easily and safely thus accessibility by both steps and ramps is preferred.

(2) *Where the change in level results in having a combination of multiple ramps and landings, other solutions should be considered.*

4.6.1.3 The approach shall be designed so that water will not accumulate on the walking surfaces.

4.6.1.4 Where ramps in the building, or that form parts of the building connect one storey to another storey, tactile and Braille signs complying with clause 8.5.5 shall be installed on adjacent walls or handrail extensions to indicate the floor level. This shall apply to office buildings, shopping complexes, multi-purpose complexes, sport complexes, hotels, boarding houses, chalets, backpacker's hotels, serviced apartments, places of public resort, public swimming pools, markets, hawkers or food centres, transport stations, interchanges, passenger terminals, colleges, universities or institutions of learning, hostels, halls of residence or dormitories, hospitals and clinics.

4.6.2 **Gradient**

4.6.2.1 The gradient of a ramp shall:

- (a) comply with Table 4; and
- (b) be consistent between landings.

4.6.2.2 Cross fall gradients of a ramp should be equal or gentler than 1:40.

4.6.2.3 Curve ramps should be avoided. If used, the recommended gradient should be equal or gentler than 1:16.

4.6.3 **Width**

4.6.3.1 Ramps that are part of accessible routes, corridors and paths shall comply with clause 4.2.1. Otherwise, the minimum clear width of a ramp shall be 1200 mm.

4.6.4 **Surfaces**

Landings

4.6.4.1 Ramps and landing surfaces shall be slip-resistant and in accordance with the current edition of SS 485.

4.6.5 **Landings**

4.6.5.1 Ramps shall have a level landing at the top and bottom of each run and also where the run changes direction as shown in Figure 34.

4.6.5.2 Landings:

- (a) shall have a level platform of 1500 mm or more;
- (b) shall be provided at regular intervals for different gradients and the intervals shall not be more than as shown in Table 5. Figure 35 illustrates a typical plan of ramps and landings;
- (c) need not be provided if the gradient of a ramp is equal or gentler than 1 : 25; and
- (d) shall conform to clause 4.4.6 if served by a doorway.

TABLE 5
Gradient and length of ramps

Gradient of ramp	1:12 – 1:14	1:15	1:20	not gentler than 1:25
Intervals (maximum length of horizontal run in metres)	9	11	15	18

Note: *For ramp gradients between those specified in Table 5, the intervals may be obtained by linear interpolation.*

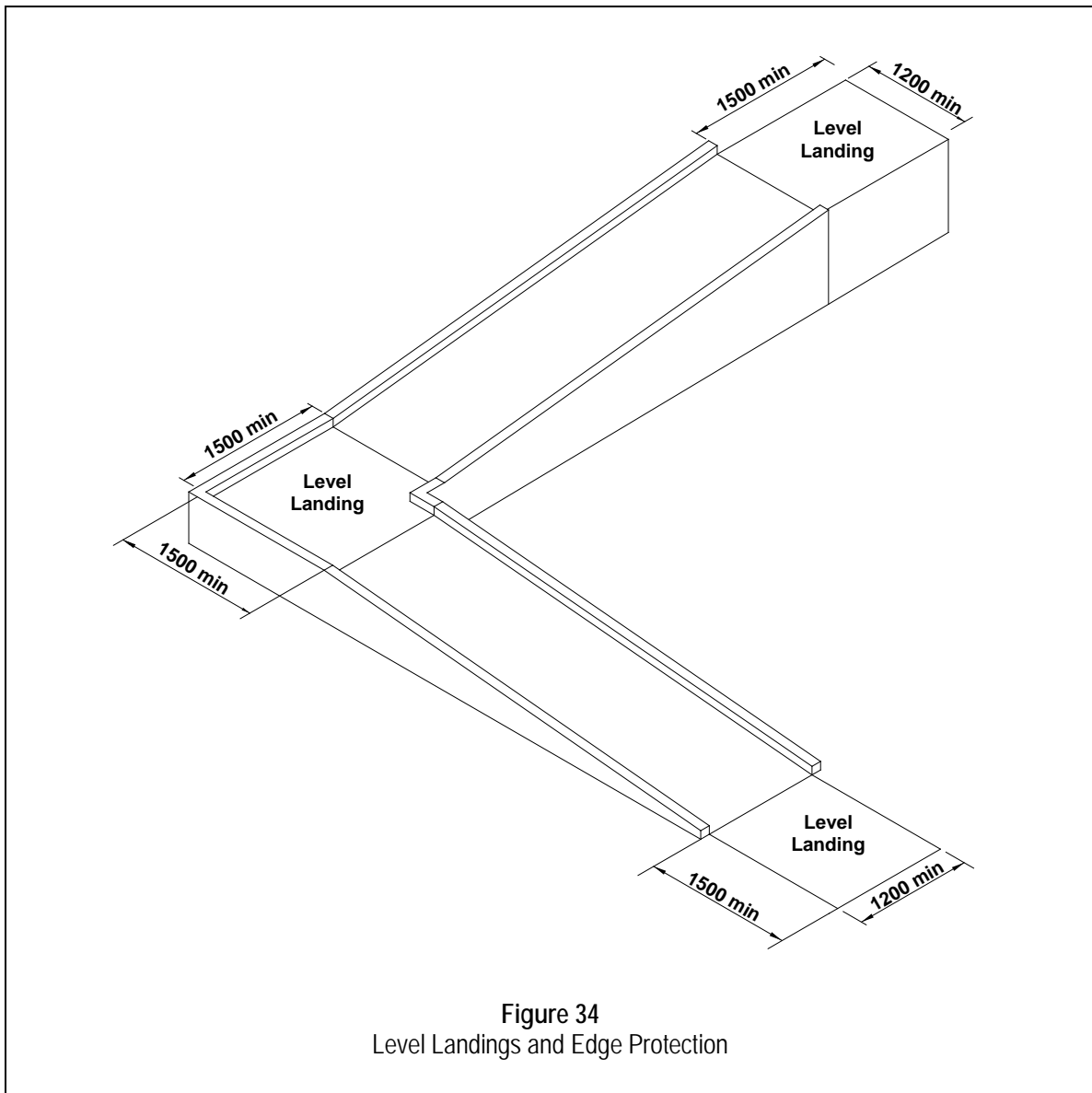
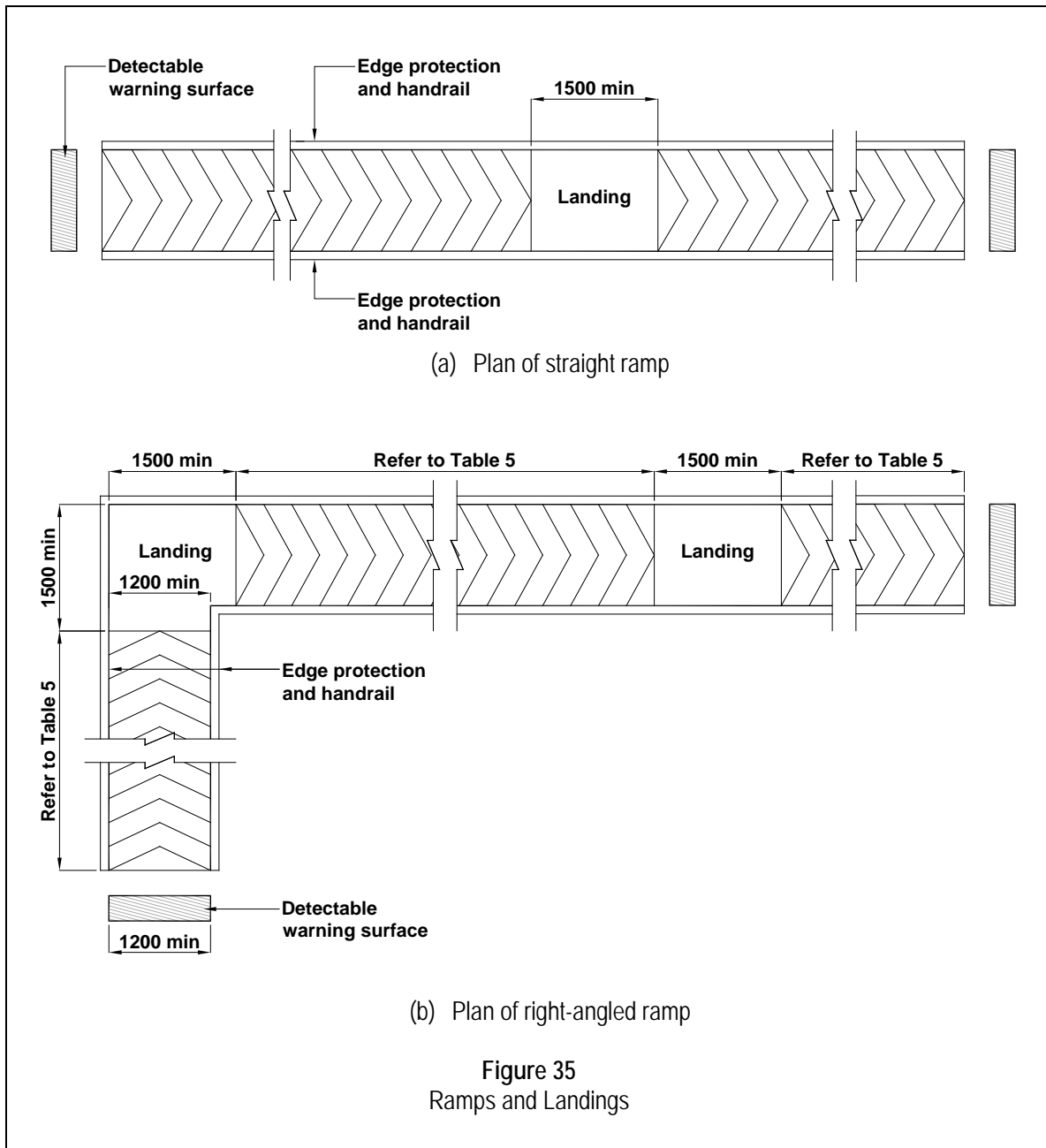

Figure 34
Level Landings and Edge Protection



4.6.6 Ramp Handrails

Ramp handrails

4.6.6.1 Except for the provision in clause 4.6.6.3, a ramp run with a rise greater than 175 mm shall have handrails that:

- (a) are on both sides;
- (b) comply with clause 4.7.3;
- (c) are placed at a height of between 800 mm and 900 mm above the floor level; and
- (d) are continuous along the entire length of the ramp.

4.6.6.2 Handrail extensions as shown in Figure 36:

- (a) shall extend horizontally for a distance of 300 mm or more beyond the top and bottom of the ramp to provide support for persons who may need help to negotiate the ramp; and
- (b) shall not project into another path of travel.

4.6.6.3 Handrails need not be provided if the gradient of a ramp is equal or gentler than 1 : 25.

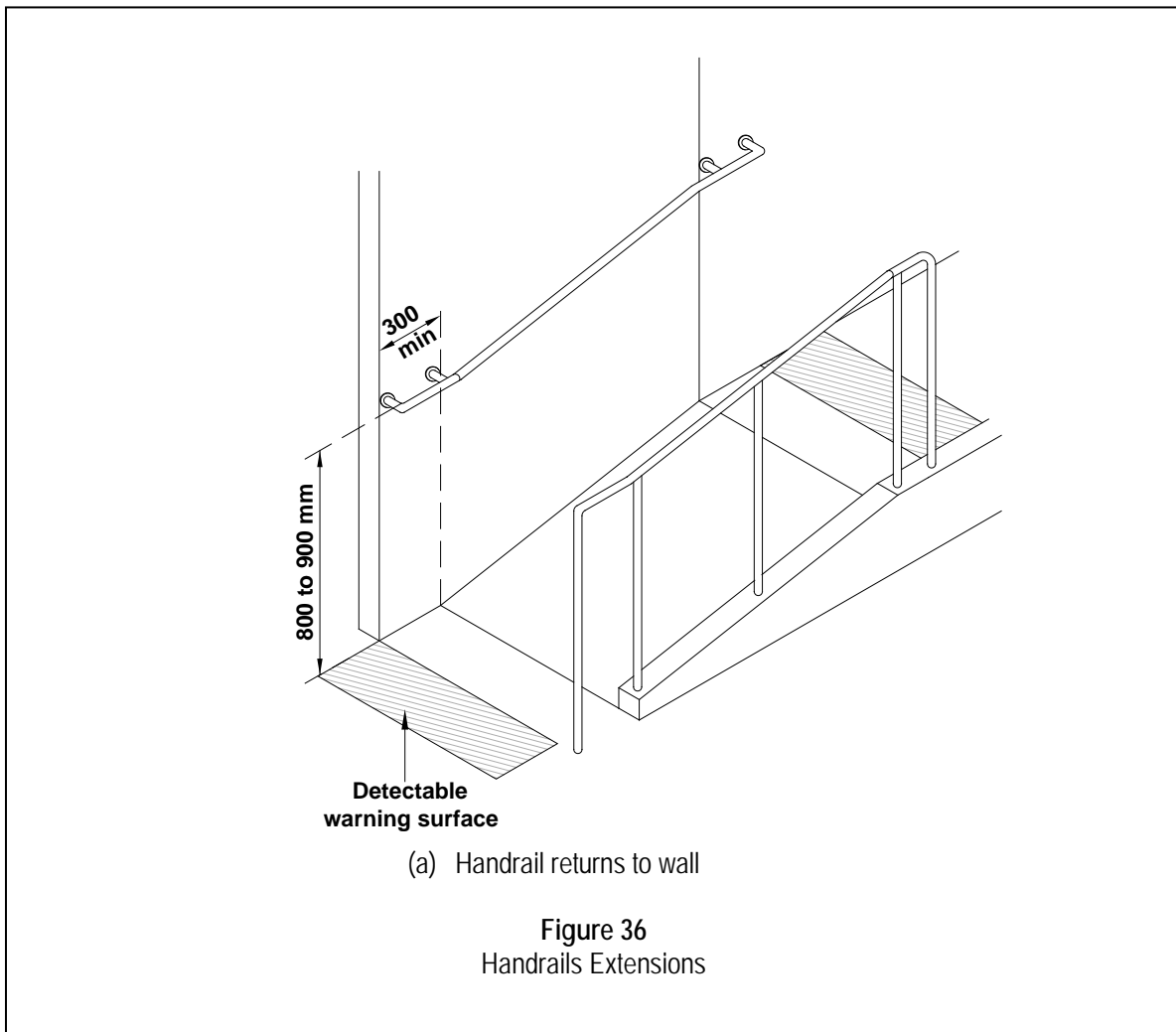

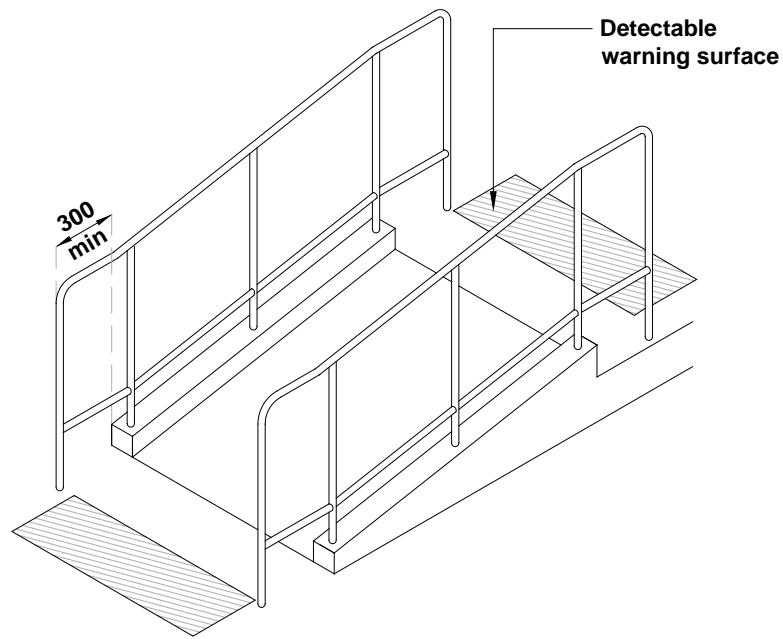

(b) Handrail returns to floor

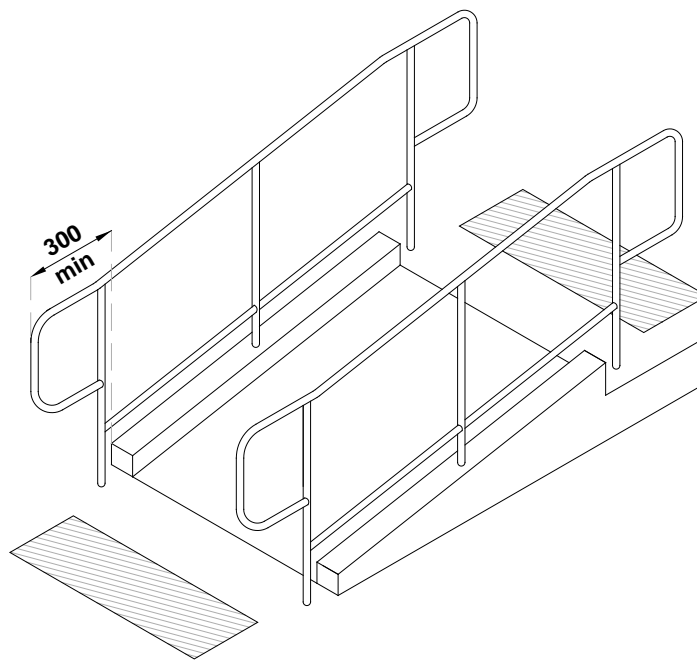

(c) Handrail returns to post

Figure 36
Handrails Extensions

4.6.7 Edge Protection

Edge protection

4.6.7.1 Ramps and landings not adjacent to a wall shall have an edge protection such as:

- (a) a kerb with a minimum height of 75 mm as shown in Figure 37 (a);
- (b) a raised barrier with its lower edge at 75 mm or less from the ramp or landing surface as shown in Figure 37 (b); or
- (c) a rail with the bottom edge at 75 mm or less from the ramp or landing surface as shown in Figure 37 (c).

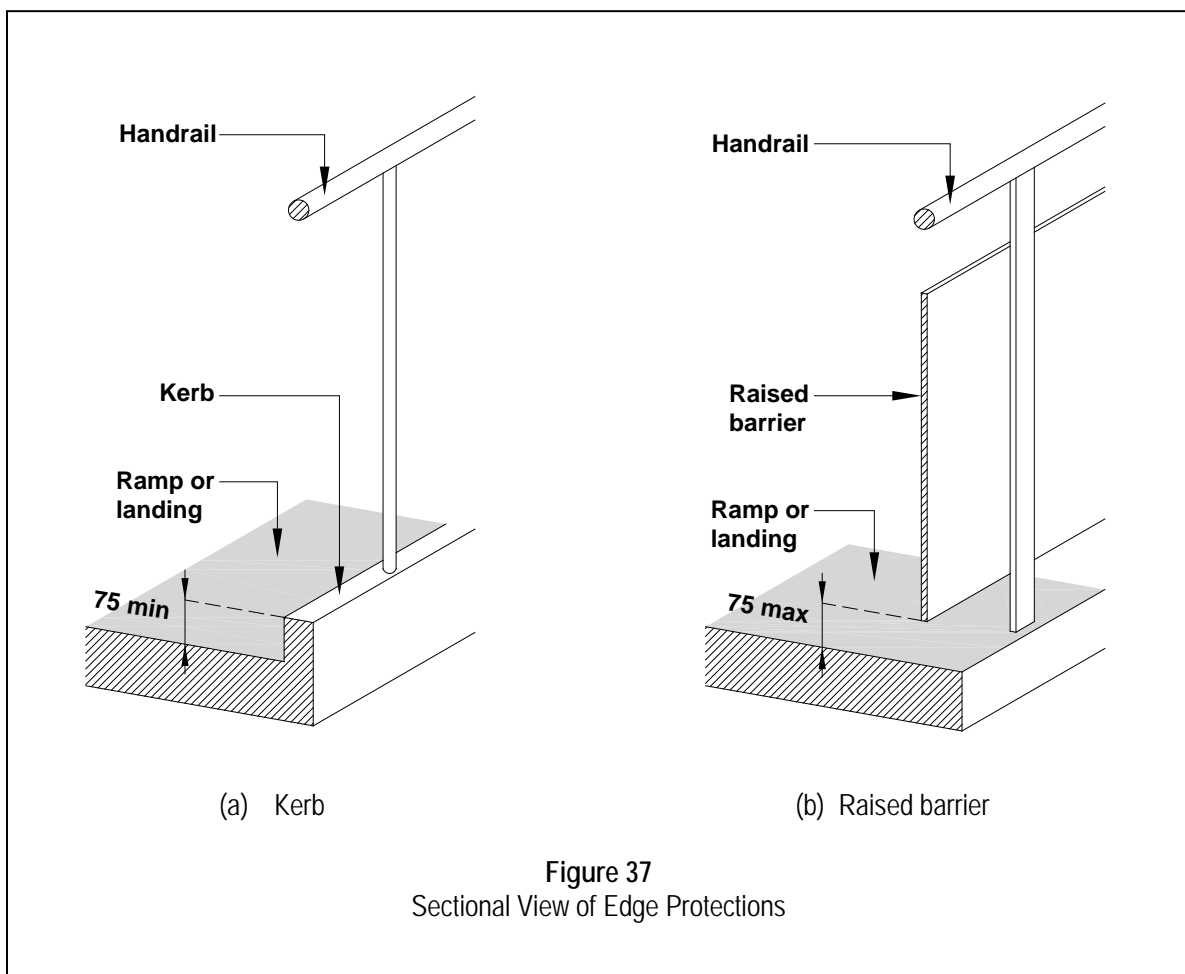

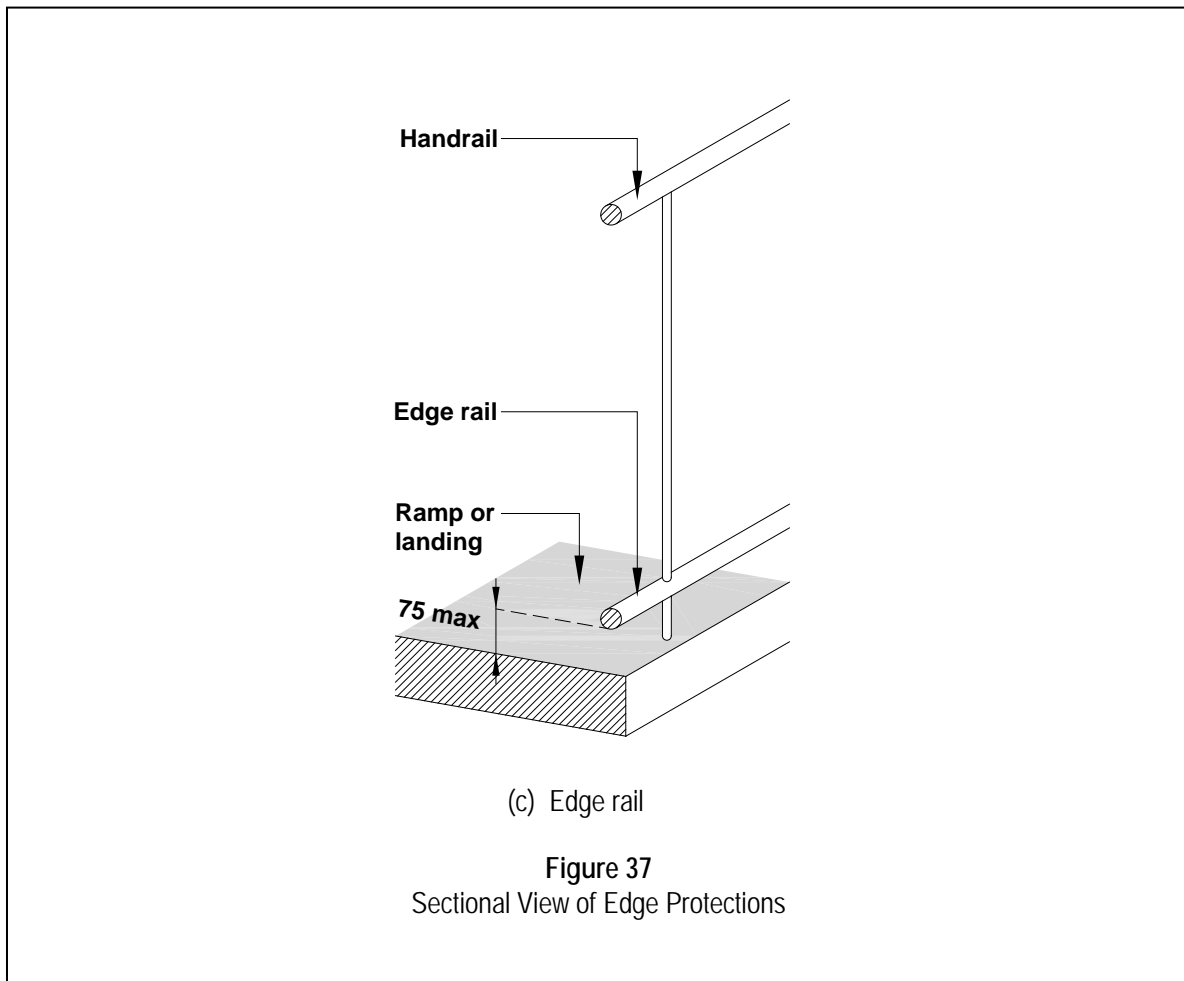

- Note:
- (1) *The ends of the rail as shown in Figure 37 (c) should be safely returned to the floor.*
 - (2) *Clause 4.6 does not apply to the footpath within the road reserve that is generally parallel and adjacent to the road.*

4.7 HANDRAILS AND GRAB BARS

Handrails /
grab bars

4.7.1 General

4.7.1.1 Handrails/grab bars are extremely important features and must be designed to be easy to grasp and to provide a firm and comfortable grip so that the hand can slide along the rail without obstruction.

4.7.1.2 Wide handrails/grab bars which allow only pinching grips are undesirable unless a proper hand-size grasping area is provided.

- Note:
- (1) *Many older persons and persons with disabilities rely on handrails/grab bars to maintain balance or prevent serious falls.*
 - (2) *Handrails and grab bars should contrast with the colour of its background to aid visibility.*

4.7.2 Structural strength

4.7.2.1 Grab bars and handrails shall be installed to resist a force of at least 1.3 kN applied vertically or horizontally.

4.7.3 Requirements

4.7.3.1 Handrails shall:

- (a) be slip-resistant;
- (b) have a circular section of 32 mm to 50 mm in diameter or an equivalent gripping surface as shown in Figure 38 (a);
- (c) be free of any sharp or abrasive elements;
- (d) have continuous gripping surfaces, without interruptions or obstructions that can break a hand hold; and
- (e) have a clear space between the handrail and all wall surfaces as shown in Figure 38(b) of:
 - (i) minimum 40 mm; or
 - (ii) minimum 60 mm where the wall has a rough surface.

Note: *A second handrail is recommended to be provided to cater to people with short statures. It should be between 600-750 mm in height.*

4.7.3.2 A recess containing a handrail shall extend at least 450 mm above the top of the rail as shown in Figure 38 (c).

4.7.3.3 Grab bars shall:

Grab bars

- (a) be slip-resistant;
- (b) have a diameter of between 32 mm to 45 mm or a shape that provides an equivalent gripping surface; and
- (c) have a space of 40 mm to 50 mm between the wall and a grab bar where mounted, adjacent to a wall.

4.7.4 Safety

4.7.4.1 The grab bars and adjacent surfaces shall be free of any sharp or abrasive elements.

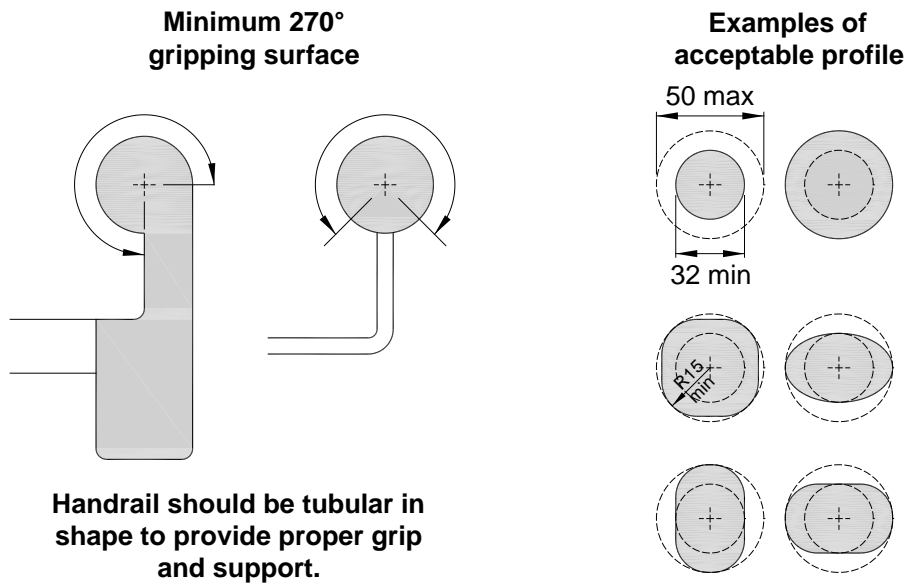

(a) Handrail cross-sectional profile

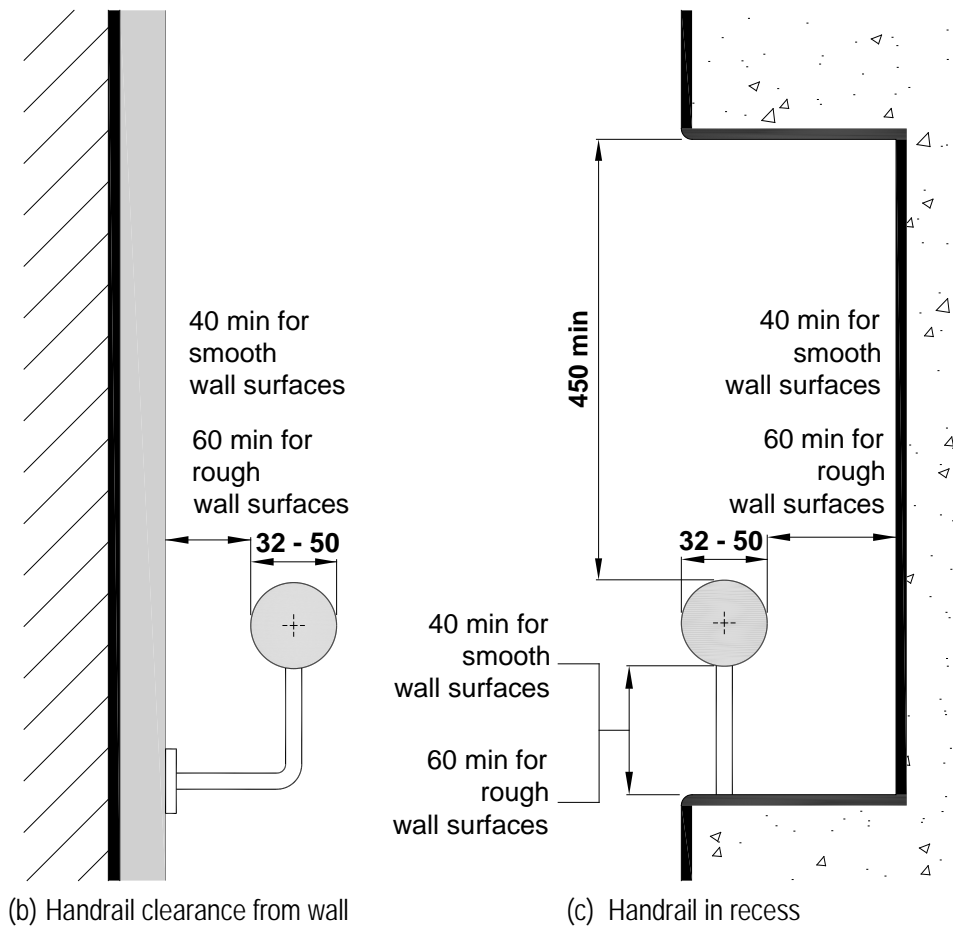
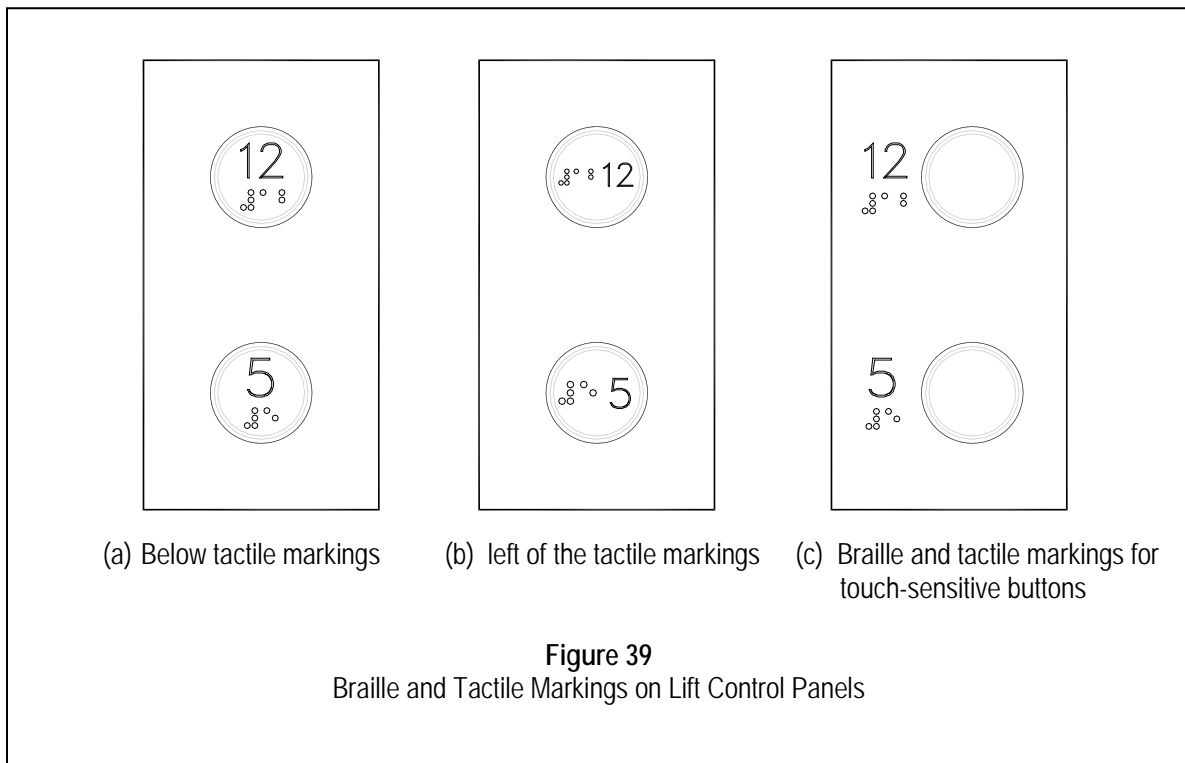

Figure 38
Handrails

4.8	PASSENGER LIFTS	Passenger lifts
4.8.1	General	
4.8.1.1	All lifts provided in a building shall include suitable provisions for the ambulant disabled and persons with sensory impairments as a means of access from one level to another.	
4.8.1.2	The emergency bell in the lift must be connected to a blinking light in the lift car to signal to persons with hearing impairments that the emergency bell has been activated.	
Note:	<i>The lift door is recommended to have a vision panel to enable persons with hearing impairment to signal for help or assistance in the event of an emergency.</i>	
4.8.2	Lift control buttons	Lift control buttons
4.8.2.1	Braille and tactile markings shall be provided on the lift control buttons and such buttons shall not be touch-sensitive. The minimum activation force shall be 3.5 N or 350 g. The Braille markings: <ul style="list-style-type: none"> (a) shall be placed below the tactile markings as illustrated in Figure 39 (a); (b) can be provided to the left of the tactile markings only if it is not possible to be placed as described in clause 4.8.2.1 (a) and is illustrated in Figure 39 (b); and (c) shall be placed at a minimum distance of 4 mm from tactile markings. 	
4.8.2.2	Braille and tactile markings shall be provided to the left of lift control buttons if the buttons are touch-sensitive and as illustrated in Figure 39 (c).	



Note: *The use of paste-on Braille on the control panel is not recommended.*

4.8.2.3 Tactile markings shall:

- (a) be in Arabic numerals or symbols;
- (b) have a dimension of between 15 mm to 20 mm high;
- (c) be raised a minimum of 1 mm; and
- (d) have a high contrasting colour background.

4.8.2.4 The lift landing call button shall be mounted adjacent to the lift and the colour shall contrast with the wall finish.

4.8.2.5 Lift landing call and car control buttons shall not be touch-sensitive but shall require a light positive pressure to activate them.

4.8.2.6 A momentary audible announcement shall be provided to signal each call registered and the storey reached.

4.8.2.7 A visual information display system shall be provided and suitably colour-contrasted.

Visual
information
display

4.8.3 **Grab bars**

Grab bar in lifts

4.8.3.1 Grab bars shall comply with clause 4.7:

- (a) be placed at a height of between 800 mm and 900 mm from the floor level;
- (b) be fixed on both sides and at the rear of the lift car; and
- (c) be allowed to have a gap of 150 mm or less if it is not continuous as illustrated in Figure 40.

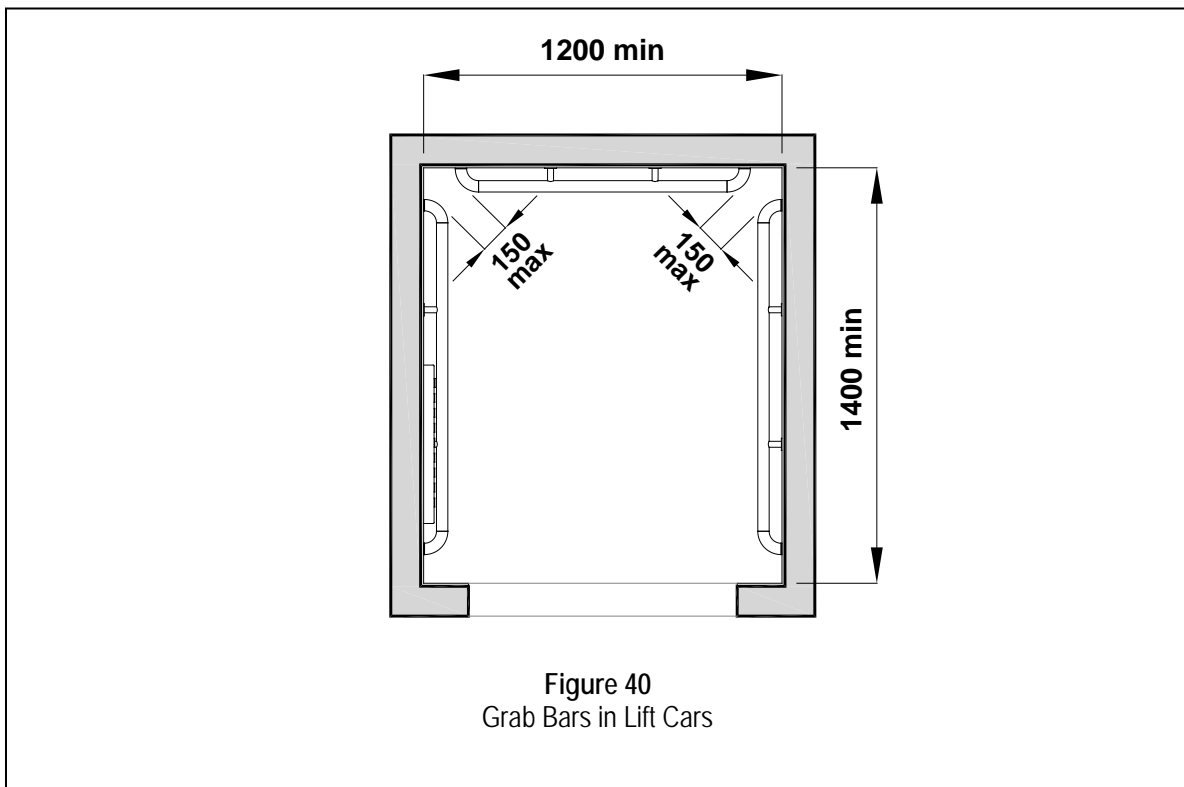

- Note:
- (1) *Grab bars should be constructed such that there are no open ends to cause hooking when used by passengers.*
 - (2) *The height of grab bars is measured from the floor level to the top of the bars.*

4.8.4 **Safety system**Safety system
in lifts

- 4.8.4.1 The closing of lift doors shall be controlled by a door protective device to ensure that doors do not make physical contact with people standing in their path. In addition, an audible signal shall be provided to signal the closing of doors to alert the lift passengers.

4.9 LIFTS DESIGNATED FOR WHEELCHAIR USERS

Lift for wheelchair users

4.9.1 General

4.9.1.1 Where lifts are provided in a building, at least one lift shall be made accessible for wheelchair users from the entrance level for vertical circulation.

4.9.1.2 The lift shall serve all levels intended for access by wheelchair users.

4.9.1.3 Lift lobby space for lifts designed for wheelchair users shall have clear manoeuvring space of 1200 mm wide X 1500 mm deep as illustrated in Figure 41.

4.9.2 Lift size

Lift size

4.9.2.1 The minimum internal lift car dimension shall be 1200 mm wide by 1400 mm deep.

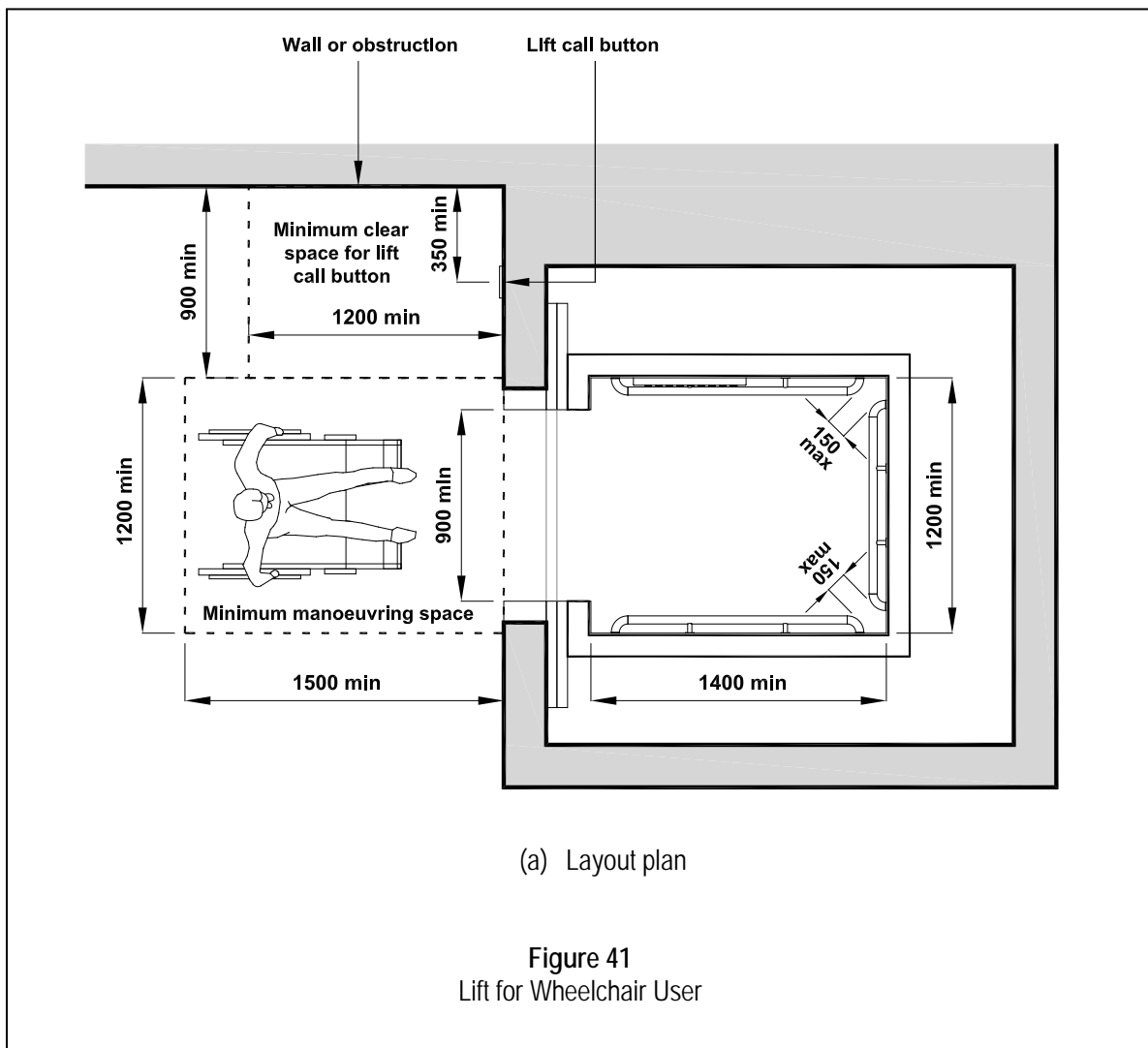

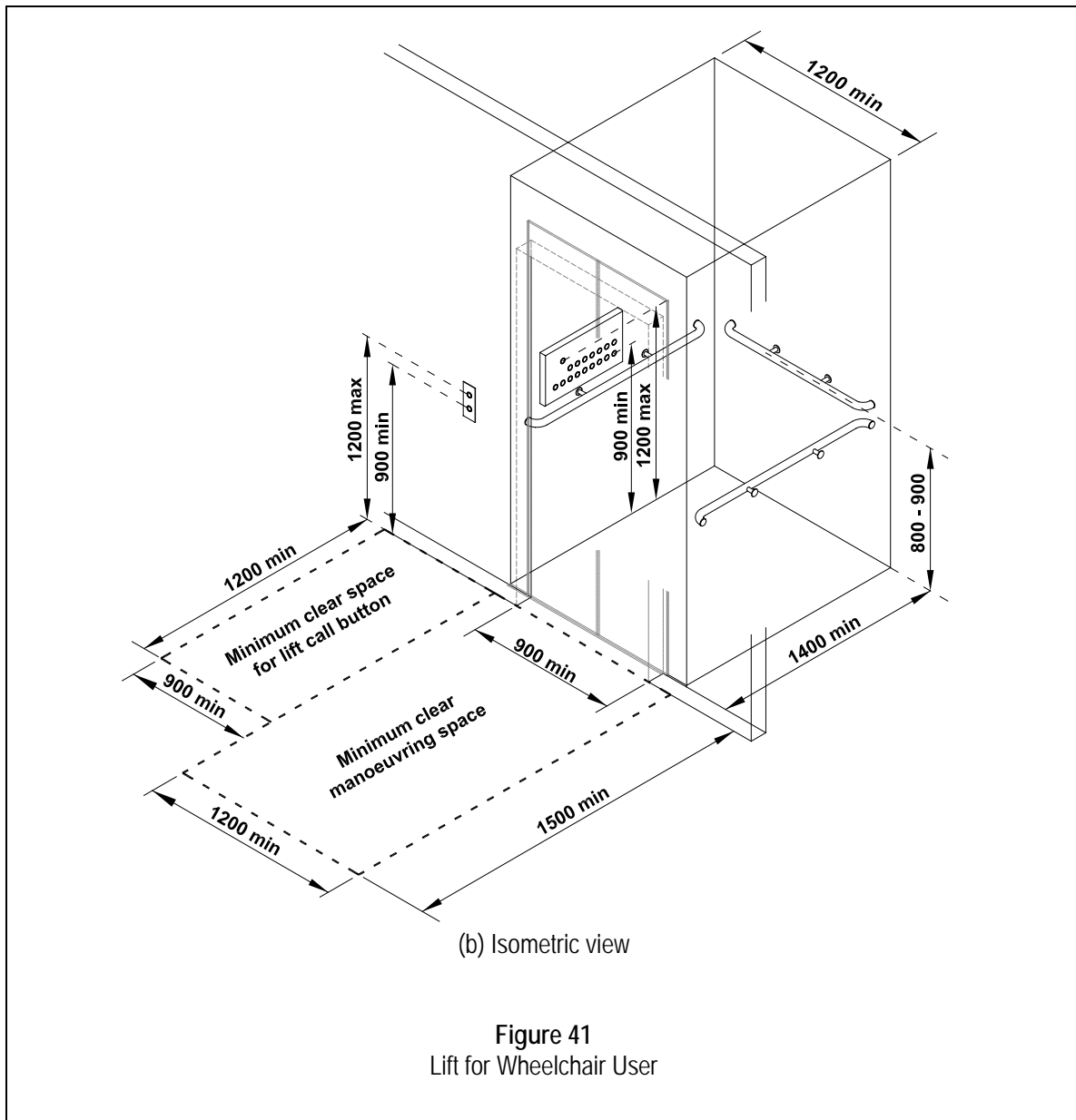

Note: *It is recommended to provide non-breakable mirrors in the lift interior to allow visual feedback for wheelchair users when reversing backwards into the lift lobby.*

4.9.3 Door width

Door width

4.9.3.1 The lift car shall have a clear door opening of at least 900 mm.

4.9.4 Lift landing call button

4.9.4.1 The lift landing call button located outside the lift shall:

- (a) have a clear floor space of at least 900 mm by 1200 mm with no obstruction placed to prevent a wheelchair user from reaching the call button;

- (b) be placed at a height of between 900 mm and 1200 mm from the floor level as shown in Figure 41;
- (c) be located at least 350 mm away from a wall or obstruction; and
- (d) be dedicated to call the lift designated for wheelchair users.

4.9.5 Lift car control buttons

Lift car control buttons

4.9.5.1 The lift car control buttons located inside the lift:

- (a) shall be placed at a height of between 900 mm and 1200 mm from the floor level; and
- (b) may be placed vertically or horizontally or both vertically and horizontally.

Note: (1) *It is recommended that all lifts should be made accessible to persons with disabilities. Where different lifts are programmed to serve certain floors during ordinary or peak periods, the lift that is designated for wheelchair users should be programmed to serve all the floors.*

- (2) *If there are two control panels inside the lift car, that is, one for the wheelchair user and the other which is mounted at eye level, the control buttons at eye level shall be provided with Braille and tactile markings.*

4.9.5.2 Keypad Design

Keypad design

4.9.5.2.1 Where there are difficulties to provide two control panels inside the lift car in high-rise buildings, keypad control panels for wheelchair users can be considered with the other control panel mounted at eye level.

The keypad shall:

- (a) be arranged in the same way as a telephone keypad. The ' * ' button shall be replaced by ' – ' while the ' # ' button is replaced by ' E ';
- (b) be placed at a height of between 900 mm and 1200 mm from the floor level;
- (c) have height of letters or numbers on the buttons of at least 15 mm and in contrasting colour; and
- (d) have button to button spacing of 60 mm or less.

Note: *The recommended keypad design requirements are indicated in Appendix G. Touch sensitive keypad control panels can also be considered for wheelchair users.*

- 4.9.6 **Signage** Lift signage
- 4.9.6.1 The symbol identifying the location of such lifts shall be provided and shall be in accordance with the requirements of Chapter 8.
- 4.10 **PLATFORM LIFTS AND WHEELCHAIR STAIRLIFTS**
- 4.10.1 **General**
- 4.10.1.1 For all buildings, a passenger lift is the most suitable form of access for people moving from one storey to another.
- 4.10.1.2 For existing buildings, and in exceptional circumstances for new developments with particular constraints, where a passenger lift cannot be accommodated, a platform lift, although not equivalent to a passenger lift, may be considered as an alternative option to provide access for persons with limited mobility.
- 4.10.2 **Platform lift** Platform lift
- 4.10.2.1 Platform lift provision shall comply with clause 4.10.1.1.
- 4.10.2.2 A platform lift, as illustrated in Figure 42, shall have a minimum clear door opening of 900 mm and clear manoeuvring space of minimum 1500 mm wide by 1500 mm deep measured from the face of the door.
- 4.10.2.3 The minimum internal size of a platform lift shall be 1100 mm wide by 1400 mm deep.
- 4.10.2.4 If full height enclosure is not required, the minimum height of the partition shall be 1000 mm.
- 4.10.2.5 The platform lift shall be provided with a barrier or flip-up ramp, if a door is not provided, to act as a safety barrier for the wheelchair and serves as an access ramp.
- 4.10.2.6 Lift control buttons shall comply with clauses 4.8.2, 4.9.4 and 4.9.5.
- 4.10.2.7 At least one grab bar complying with clause 4.8.3 shall be placed on one side of the lift.

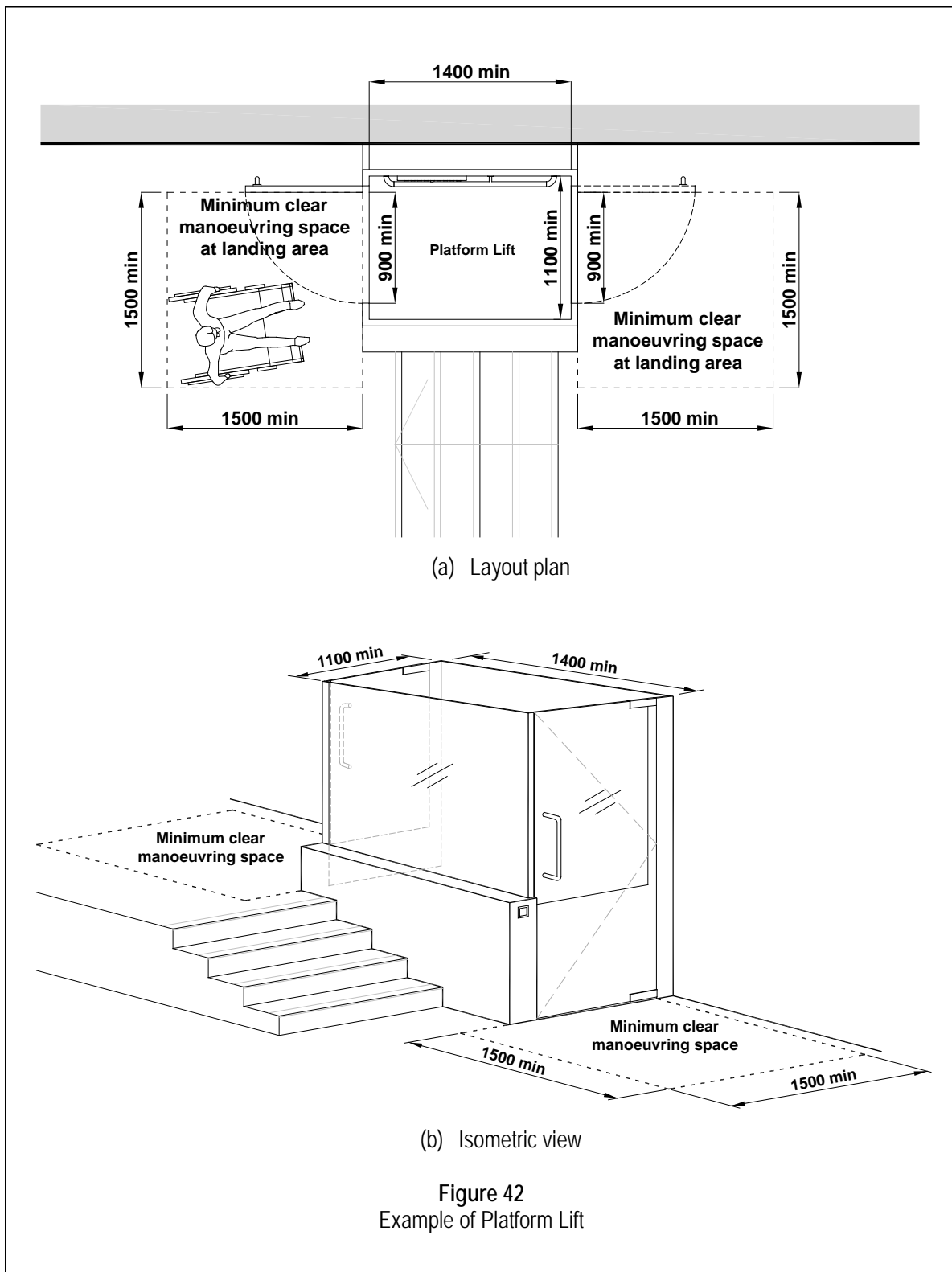

4.10.3 **Wheelchair stairlift**

Wheelchair stairlift

4.10.3.1 Where it is impracticable to provide a passenger lift, a ramp or platform lift in an existing building, a wheelchair stairlift can be considered as a reasonable alternative for vertical circulation within the building.

4.10.3.2 A wheelchair stairlift is illustrated in Figure 43.

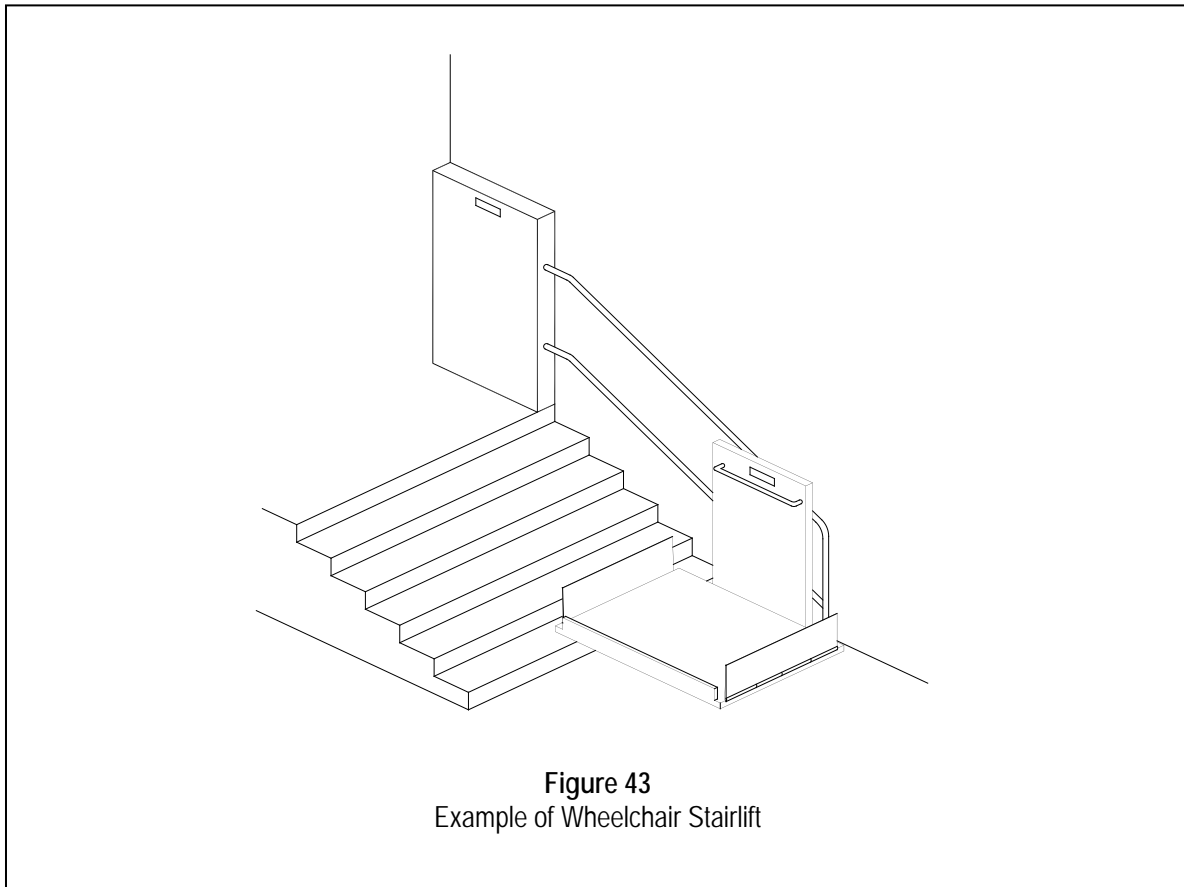

4.11 STAIRS

Stairs

4.11.1 General

4.11.1.1 Staircases should provide viable means of access between different levels. Other than staircases for ambulant disabled, exit staircases for evacuation and staircases within the public circulation areas in the building shall be designed to comply with the following requirements:

- (a) steps profile in accordance with clause 4.11.2;
- (b) detectable warning surfaces in accordance with clause 4.11.3; and
- (c) stair handrails in accordance with clause 4.11.4.

4.11.1.2 In addition to clause 4.11.1.1, where staircases in the building, or which form part of the building connects one storey to another storey, tactile and Braille signs as shown in Figure 44 (c) and Figure 45 complying with clause 8.5.5 shall be installed on adjacent walls or handrail extensions to indicate the floor level. This shall apply to office buildings, shopping complexes, multi-purpose complexes, sport complexes, hotels, boarding houses, chalets, backpacker's hotels, serviced apartments, places of public resort, public swimming pools, markets, hawkers or food centres, transport stations, interchanges, passenger terminals, colleges, universities or institution of learning, hostels, halls of residence or dormitories, hospitals and clinics.

4.11.2 Steps profile

4.11.2.1 Stair nosings shall not project beyond the face of the riser and the riser may be vertical or have a splay backwards up to a maximum 25 mm, as shown in Figure 44 (a).

4.11.2.2 All steps shall be fitted with non-slip nosing strips between 50 mm and 65 mm in width with permanent contrasting colours.

4.11.2.3 The treads and walls of the staircase shall have contrasting colours to alert persons with visual impairments of the presence of steps.

Note: *The contrasting colour of the nosing is meant to ensure that the tread edge is clearly visible in descent.*

4.11.3 Detectable warning surfaces

4.11.3.1 Detectable warning surfaces shall:

- (a) be provided at the top, bottom and intermediate landings leading to another path of travel;
- (b) extend the full width of the stairs for a depth of 600 mm commencing 300 mm back from the stairs as shown in Figure 44 (a); and
- (c) consist of flooring material that is:
 - (i) contrasting in colour with the surrounding flooring material; and
 - (ii) of a different texture from the surrounding flooring material.

4.11.3.2 Detectable warning surfaces are not required at enclosed intermediate landings where handrails are continuous and do not lead to another path of travel.

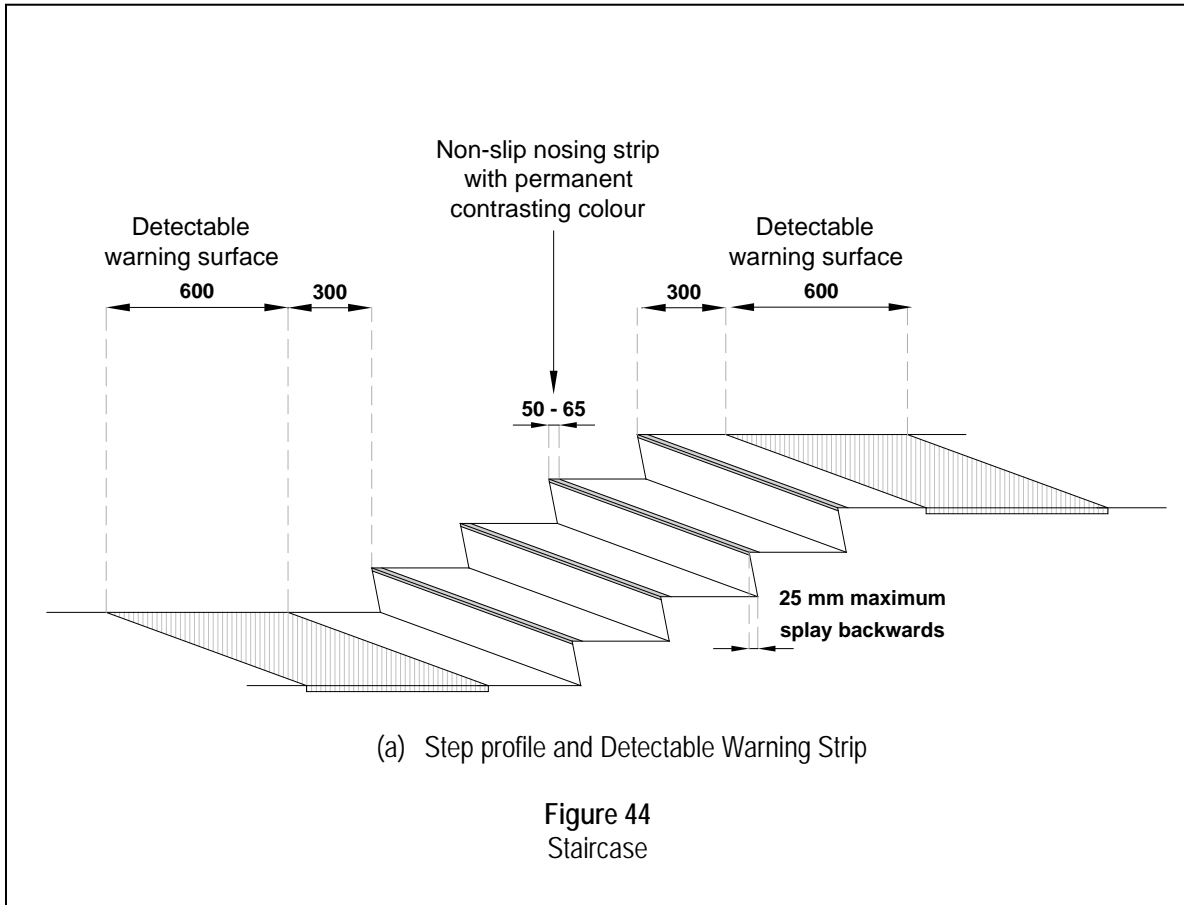

- Note:
- (1) *Strongly patterned carpets shall not be used for stairs as they obscure the definition of the tread edges and can cause danger to users.*
 - (2) *Bright stainless steel or polished brass should not be used for nosing strips as glare reflection can cause disorientation to persons with visual impairments.*
 - (3) *The detectable warning surface is to alert persons with visual impairments that they are approaching steps and to be extra careful.*

4.11.4 Stair handrails

4.11.4.1 Handrails for stairs shall:

- (a) comply with clauses 4.7.2 and 4.7.3;
- (b) be positioned between 800 mm and 1000 mm measured from the pitch line vertically to the top of the handrails;
- (c) be continuous throughout the entire length of stairs and enclosed intermediate landings where it do not lead to another path of travel; and
- (d) extend not less than 300 mm beyond the top and bottom steps.

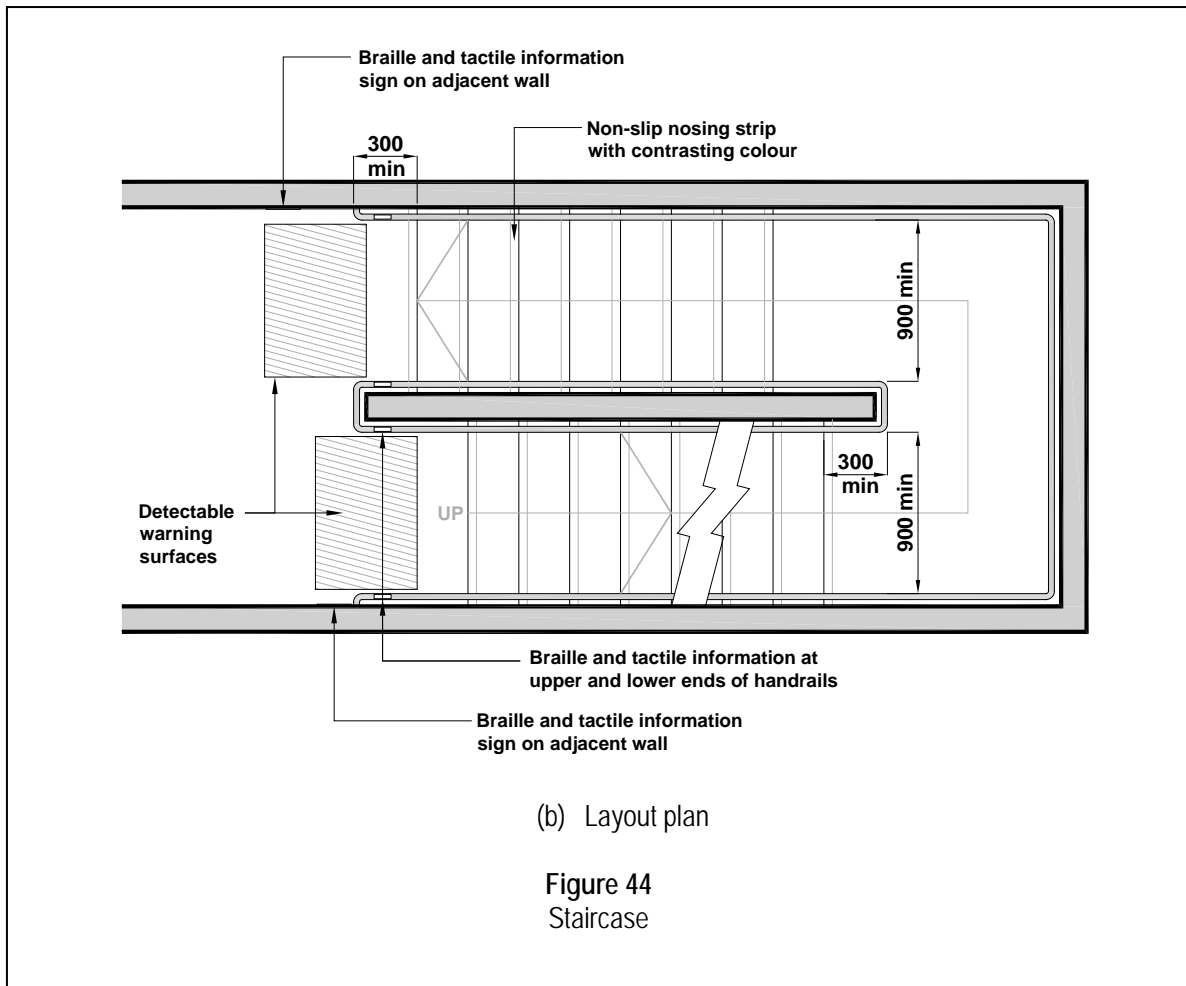

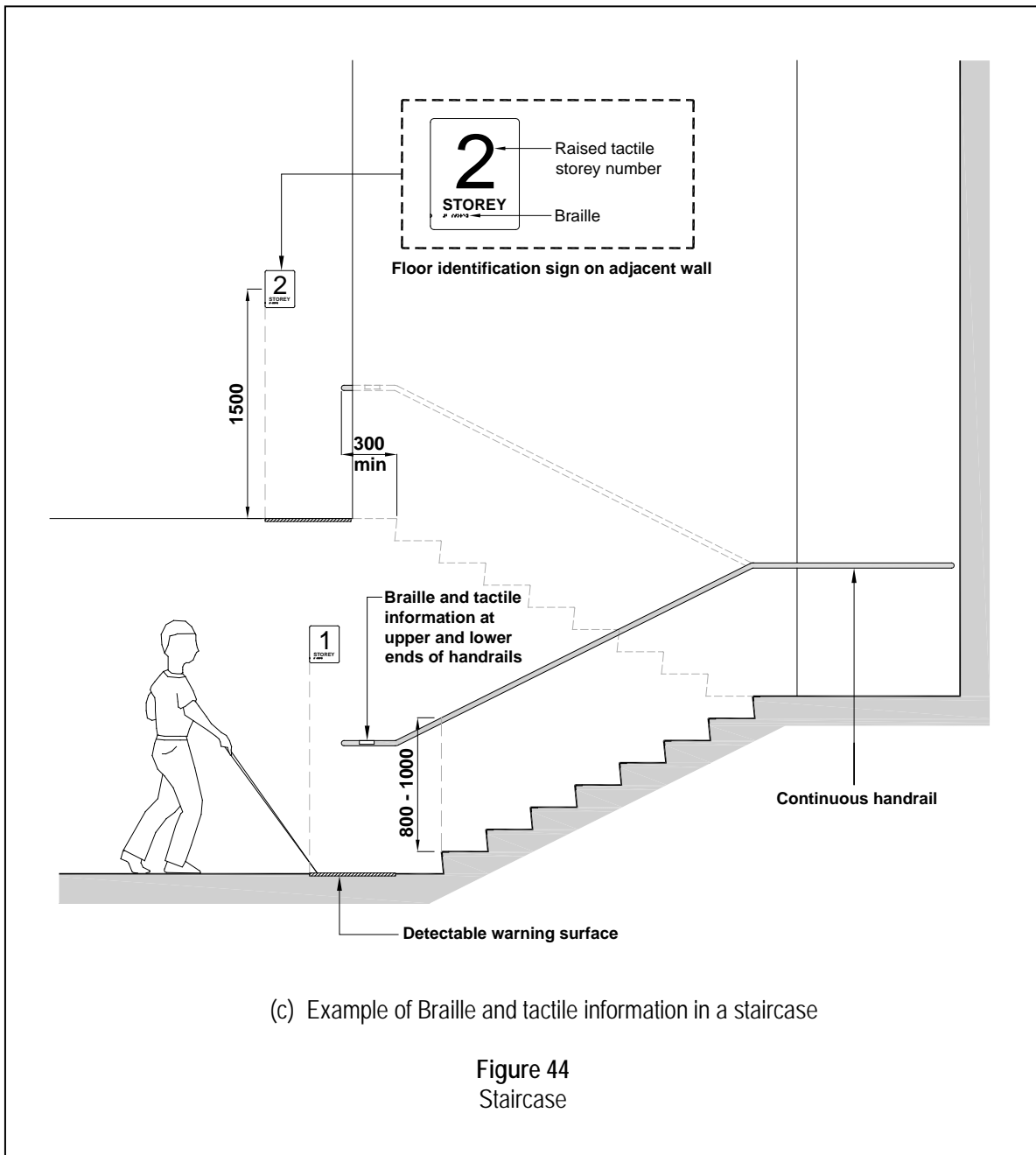

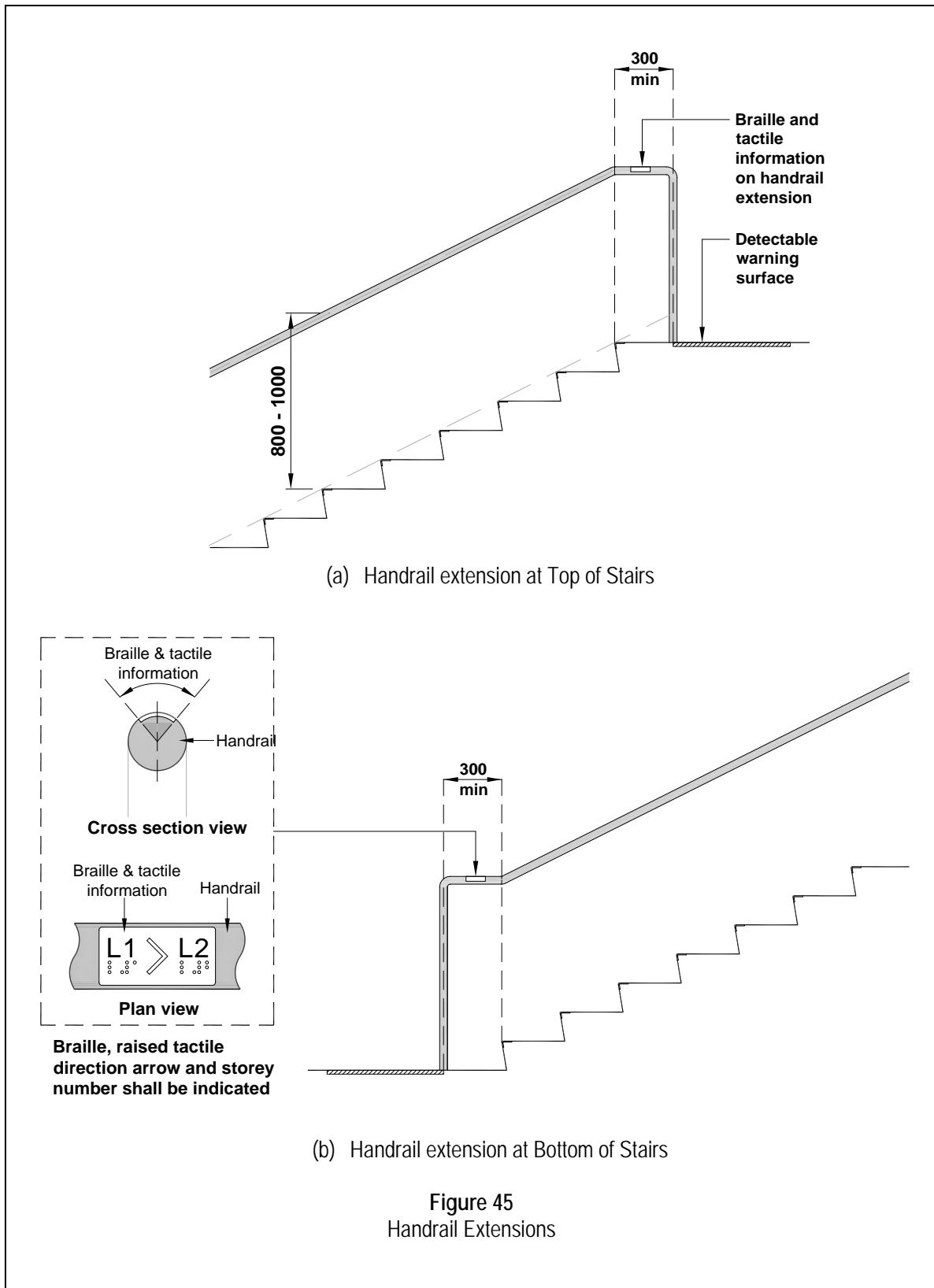

4.12 STAIRS FOR AMBULANT DISABLEDStaircase for
ambulant
disabled

4.12.1 Staircases for ambulant disabled are intended as an optional means of vertical travel for older persons and persons with ambulatory disabilities.

4.12.2 If provided, it shall be designed to comply with the requirements of clause 4.11.1.1 and the following:

- (a) handrail installed on both sides as shown in Figure 44 (b) and (c);
- (b) continuous handrail throughout the entire length of stairs and extend not less than 300 mm beyond the top and bottom step as shown in Figure 45;
- (c) have tactile and Braille signs installed on adjacent walls or handrail extensions complying with clause 8.5.5 as shown in Figure 44 (c);
- (d) uniform risers of maximum 150 mm and treads of minimum 300 mm; and
- (e) no open risers as shown in Figure 46.

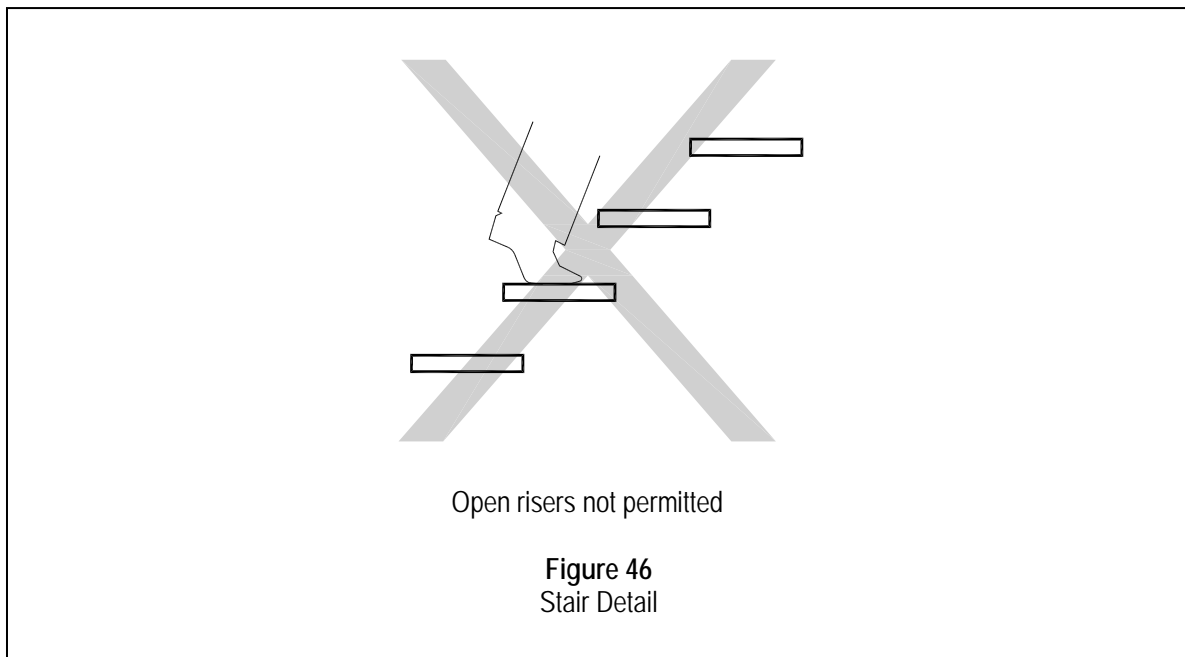

CHAPTER 5

SANITARY PROVISION

Objective : Use of Sanitary Facilities

Where washrooms are open to the public, employees, staff, students, patients or intended users, they shall be equally accessible to persons with disabilities.

- **General** CI 5.1
- **Accessible Individual Washrooms** CI 5.2
- **Accessible Water Closet Compartments** CI 5.3
- **Water Closet Compartments for Ambulant Disabled** CI 5.4
- **Urinals for Ambulant Disabled** CI 5.5
- **Components in the Accessible Washroom** CI 5.6
- **Bath Facilities** CI 5.7
- **Wheelchair transfer** CI 5.8

5.1	GENERAL	Scope
5.1.1	At every level of a non-residential building where toilets are provided, at least one accessible individual washroom shall be provided as described in clause 5.2.	Accessible washroom provision
5.1.2	In non-residential buildings, other than factory, workshop, office/showroom areas in warehouses or industrial buildings, where two or more clusters of toilets are provided at the same level but at different locations, the corresponding number of accessible individual washrooms shall be provided. Each accessible individual washroom may be replaced with one accessible water closet compartment in the male and female toilets as described in clause 5.3, provided that there is at least one accessible individual washroom on the same level.	
5.1.3	For pre-schools, schools, colleges, universities, institutions of learning, hostels, dormitories and halls of residence, the provision of accessible toilet to every cluster of toilets at each level need not be in accordance with clause 5.1.2 if the following conditions are met: (a) the accessible toilet provided serves every function area at that level; (Example as illustrated in Figure 47) (b) the accessible toilet is 50 m or less from each function area; and	Exception

- (c) directional signs from each function area to the accessible toilet are provided.

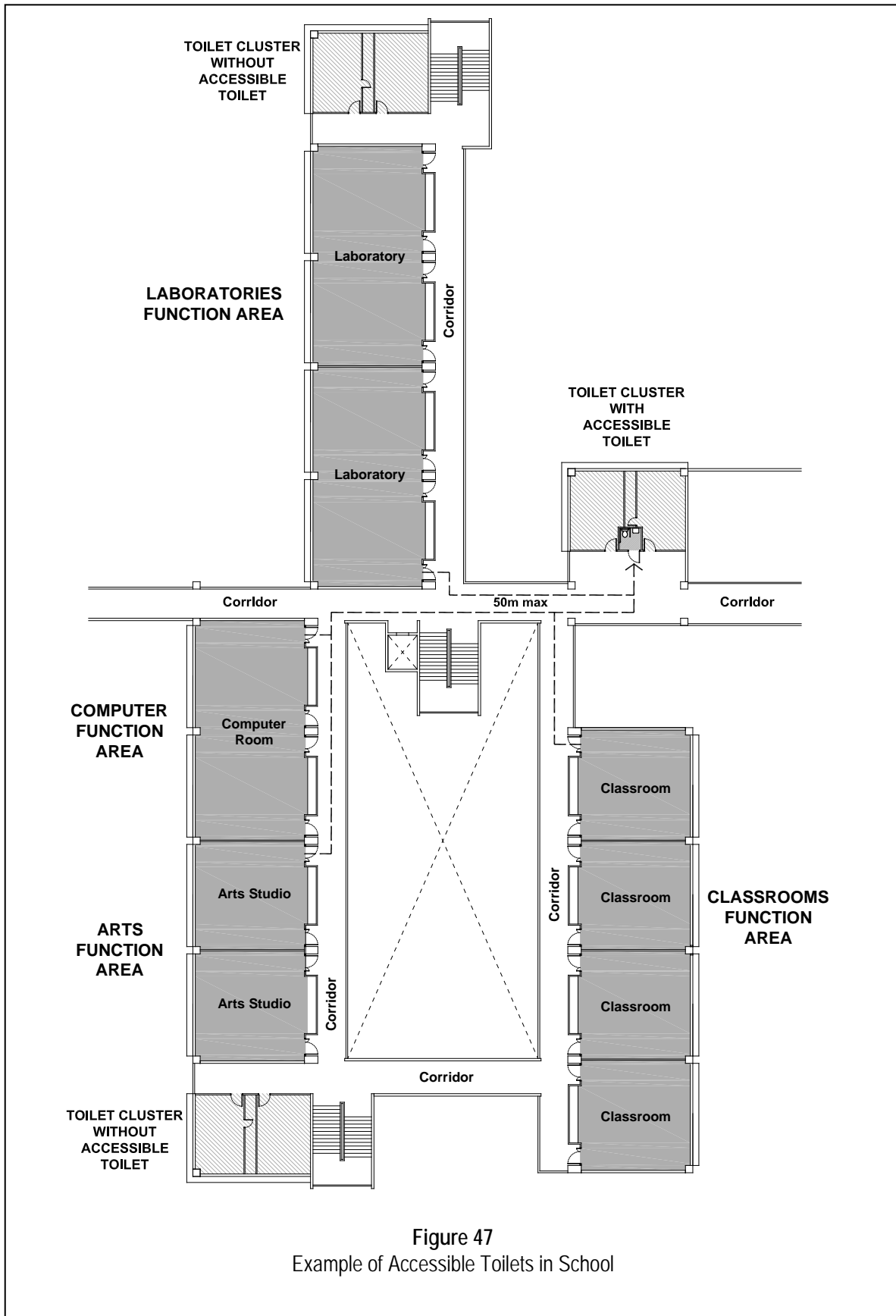

Figure 47
Example of Accessible Toilets in School

Note: *A group of rooms or spaces that serve similar functions will constitute a 'function area'.*

- 5.1.4 In addition to clause 5.1.1 and clause 5.1.2, where toilets are provided: Ambulant disabled WC compartment
- (a) one water closet compartment for the ambulant disabled as described in clause 5.4 shall be provided for the first five numbers of water closet compartments or part thereof with an addition of similar water closet compartments for every subsequent five water closet compartments or part thereof. (For example, for provision of six water closet compartments, at least two shall cater to the ambulant disabled);
- (b) where urinals are provided, at least one shall comply with clause 5.5 to cater to the ambulant disabled.

Note: *Clause 5.1.4 shall not apply to pre-schools, primary and secondary schools and its hostels, hall of residences or dormitories, common facilities in a residential development, factory, workshop, office/showroom areas in warehouses or industrial buildings and worker's dormitories.*

- 5.1.5 At least one wash basin complying with clause 5.6.5 shall be provided in the accessible individual washroom or toilet cluster with accessible water closet compartments. Wash basin
- 5.1.6 Signs at washroom entrances shall comply with symbols as described in clause 8.2.2 and should be clearly visible complying with clause 8.5. Signage
- 5.1.7 In addition to clause 5.1.6, signs at public toilets shall provide tactile and Braille signs complying with clause 8.5.5. This shall apply to office buildings, shopping complexes, multi-purpose complexes, sports complexes, hotels, boarding houses, chalets, backpacker's hotels, serviced apartments, places of public resort, public swimming pools, markets, hawker or food centres, transport stations, interchanges, passenger terminals, colleges, universities or institutions of learning, hostels, halls of residence or dormitories, hospitals and clinics.
- 5.1.8 Where a building is required to provide family-friendly facilities in compliance with clause 6.9.1, there shall be child-friendly sanitary facilities to be provided in accordance with clause 6.9.4. Child-friendly sanitary facilities
- 5.1.9 In every residential unit, there shall be at least one bathroom with toilet and shower/bathing facilities that can be readily retrofitted for older persons and wheelchair users complying with Clause 7.3. Residential unit

5.2 ACCESSIBLE INDIVIDUAL WASHROOMS

Accessible
individual
washroom

5.2.1 Accessible individual washrooms shall:

- (a) have minimum clear dimensions between opposite walls of 1750 mm or more;
- (b) have a clear space of 900 mm by 1500 mm or more adjacent to the water closet;
- (c) be equipped with a door complying with clause 5.6.1;
- (d) have grab bars complying with clause 5.6.2;
- (e) have essential washroom accessories complying with clause 5.6.3;
- (f) be equipped with an emergency call bell in accordance with clause 5.6.4;
- (g) have a wash basin complying with clause 5.6.5;
- (h) have a water closet complying with clause 5.6.6;
- (i) be equipped with two coat hooks mounted on a side wall at two different heights of about 1500 mm and 1100 mm from the floor. The hooks shall not project more than 40 mm from the wall;
- (j) be equipped with a self-closing water spray head connected by a flexible hose beside the water closet seat for cleaning purposes;
- (k) have a toilet roll dispenser that is reachable and does not interfere with the use of grab bars that should:
 - (i) be mounted below the horizontal grab bar at 300 mm or less from the front edge of the seat and at a height of between 50 mm to 250 mm from the top of the water closet seat; or
 - (ii) where jumbo toilet roll dispenser is provided, it shall be mounted at a height between 150 mm to 200 mm above the horizontal grab bar and approximately 50 mm from the front edge of the seat to the centerline of the toilet roll dispenser as illustrated in Figure 49; and
- (l) where possible, be equipped with a shelf or counter measuring 400 mm x 200 mm and fixed at a height of between 900 mm and 1100 mm from the floor.

Note: *The minimum clear dimensions between opposite walls specified in clause 5.2.1 (a) should be used as a guide to ensure all critical dimensions are met. Additional space should be allowed for construction tolerances, non-alignment and protrusions in implementation.*

5.2.2 An accessible individual washroom for the wheelchair user is illustrated in Figure 48.

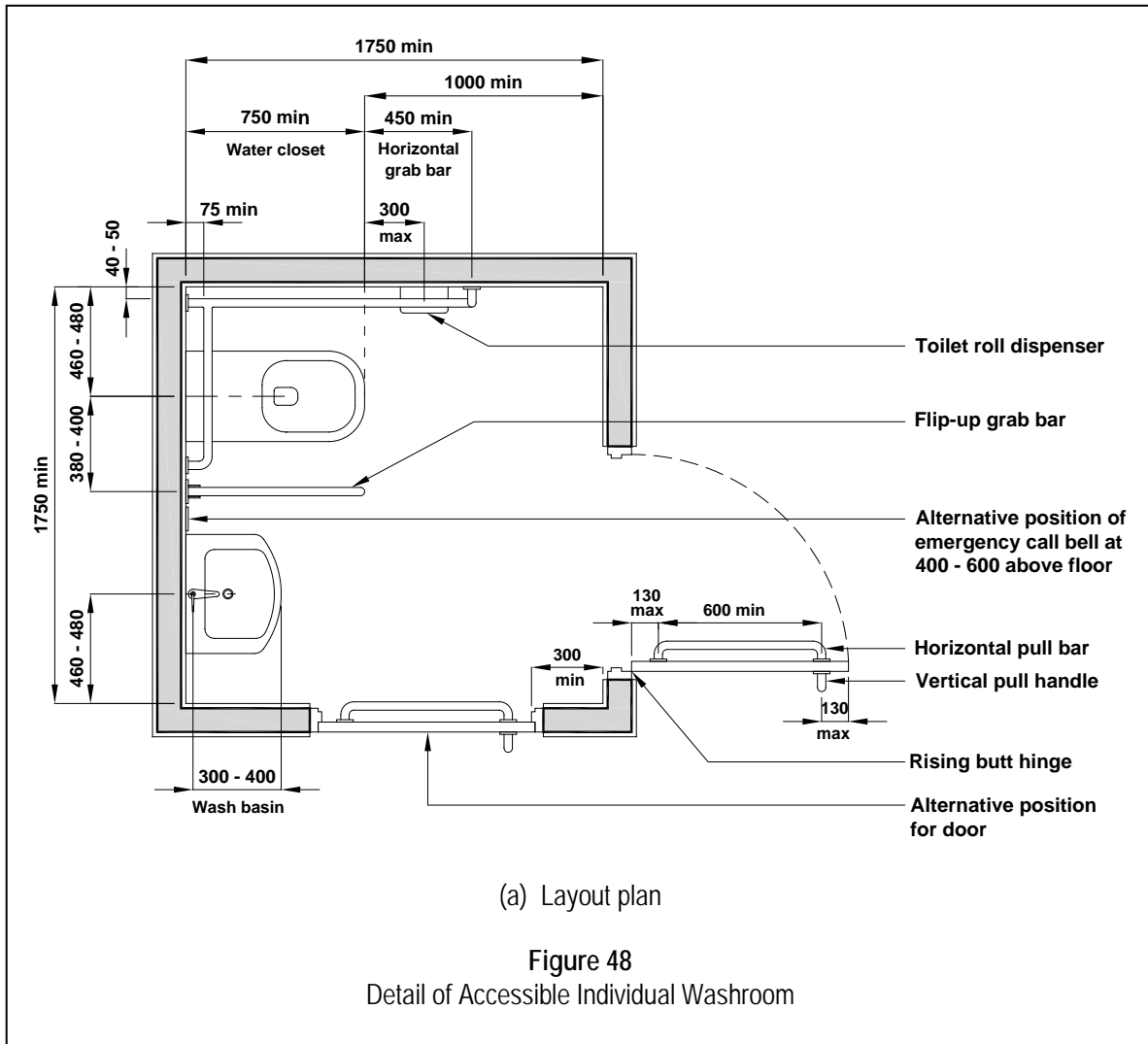

Note: *If obstructions such as pipe works are present, adjustment in the compartment size shall be made to meet the overall dimensions required for the manoeuvring of wheelchairs.*

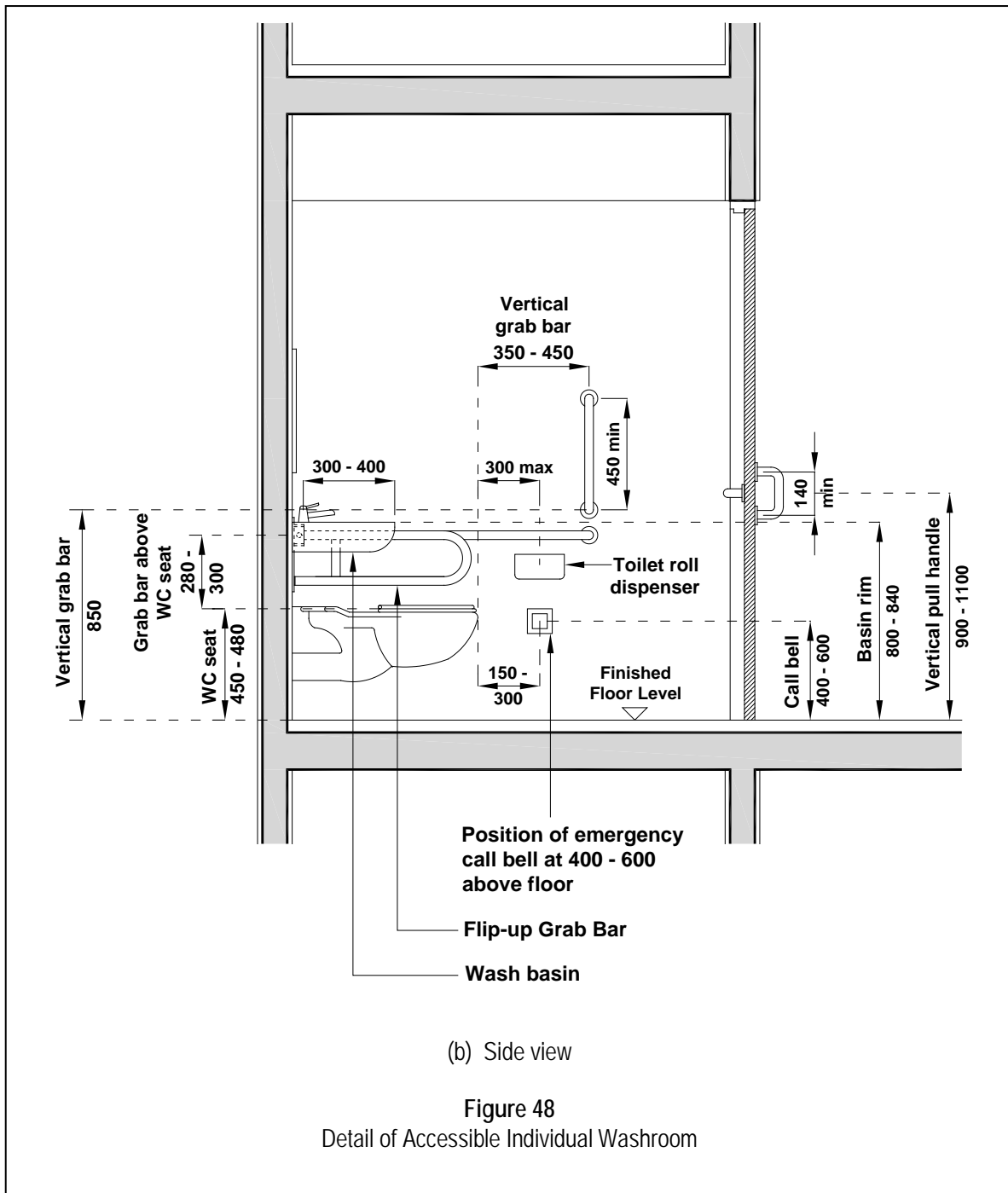

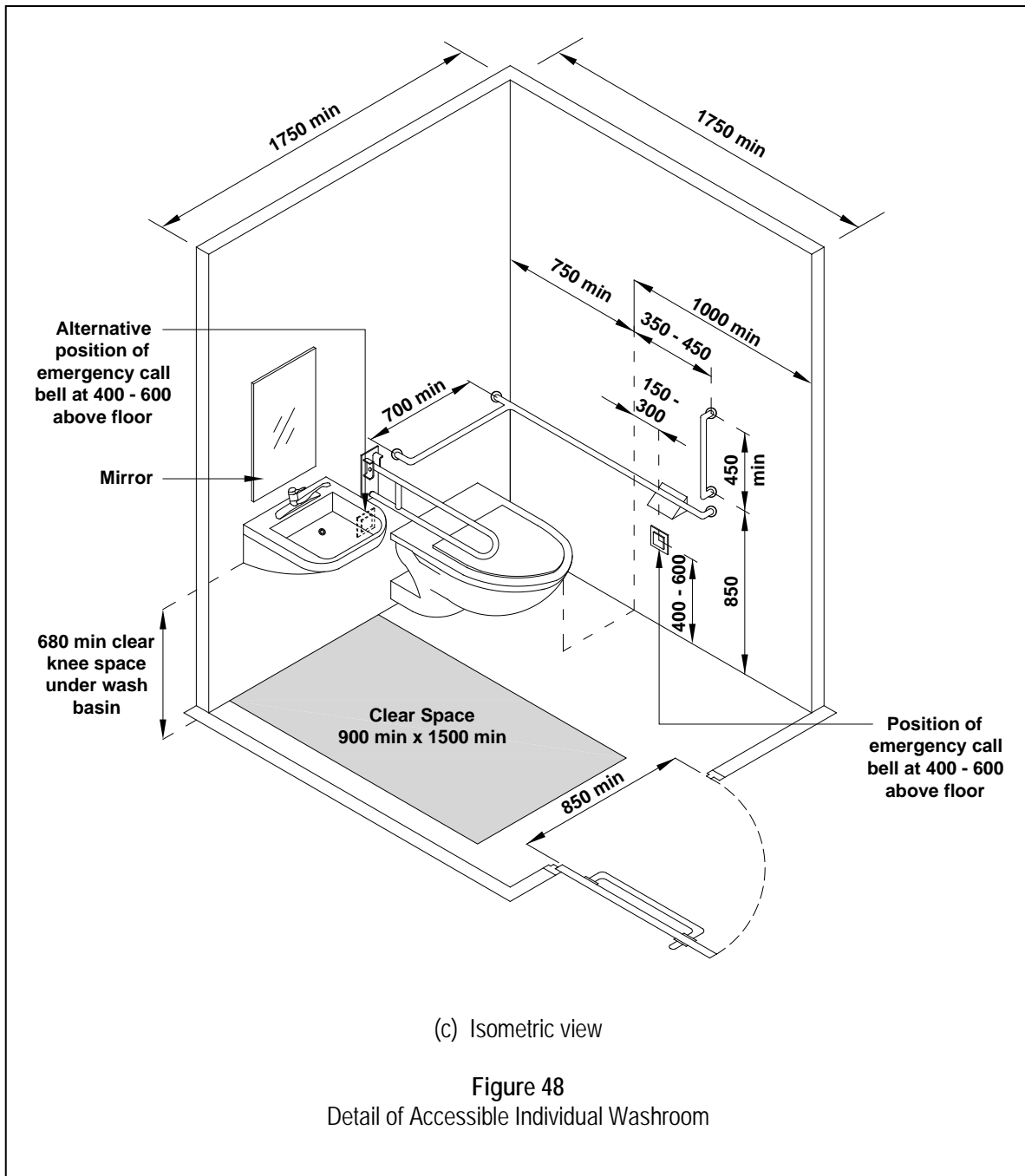

- Note:
- (1) An accessible individual washroom is a unisex washroom containing a wash basin and a water closet.
 - (2) An accessible individual washroom is used by persons with different disabilities. It is suitable when persons or children with disabilities and their respective caregivers or parents are of the opposite sex.
 - (3) For public buildings such as shopping complexes, office buildings and hotels, an accessible individual washroom is preferred over a water closet compartment for the reason given in Note (2) above.

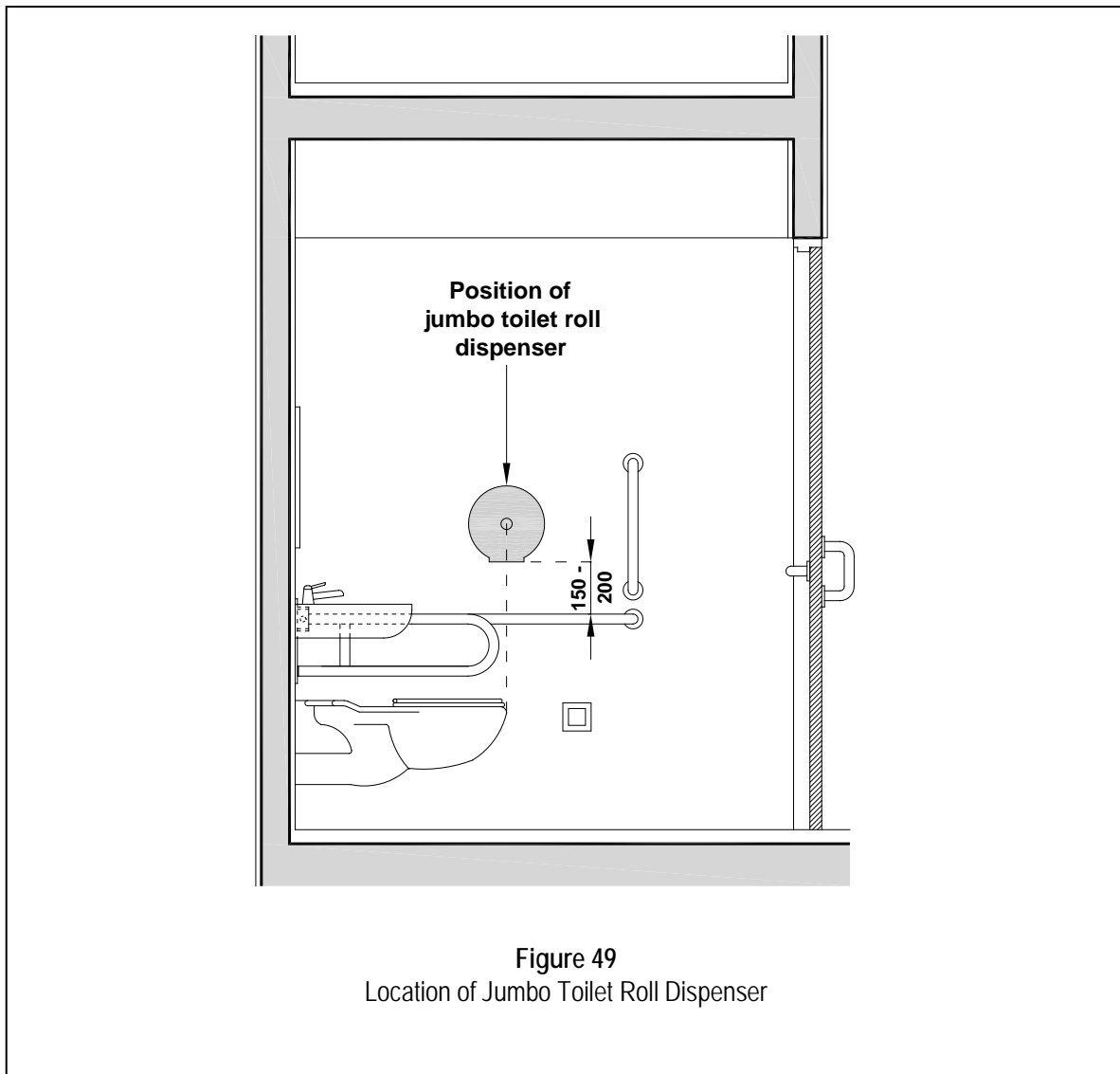

5.3 ACCESSIBLE WATER CLOSET COMPARTMENTS

Accessible WC
compartments

5.3.1 An accessible water closet compartment shall:

- (a) have clear internal dimensions of 1500 mm by 1750 mm or more;
- (b) be equipped with a door complying with clause 5.6.1;
- (c) have grab bars complying with clause 5.6.2;
- (d) be equipped with an emergency call bell in accordance with clause 5.6.4;
- (e) have a water closet complying with clause 5.6.6;

- (f) be equipped with two coat hooks mounted on a side wall at two different heights of about 1500 mm and 1100 mm from the floor. The hooks shall not project more than 40 mm from the wall;
- (g) be equipped with a self-closing water spray head connected by a flexible hose beside the water closet seat for cleaning purposes; and
- (h) have a toilet roll dispenser that is reachable and does not interfere with the use of grab bars as specified in clause 5.2.1 (k).

5.3.2 An accessible water closet compartment is illustrated in Figure 50 and 51.

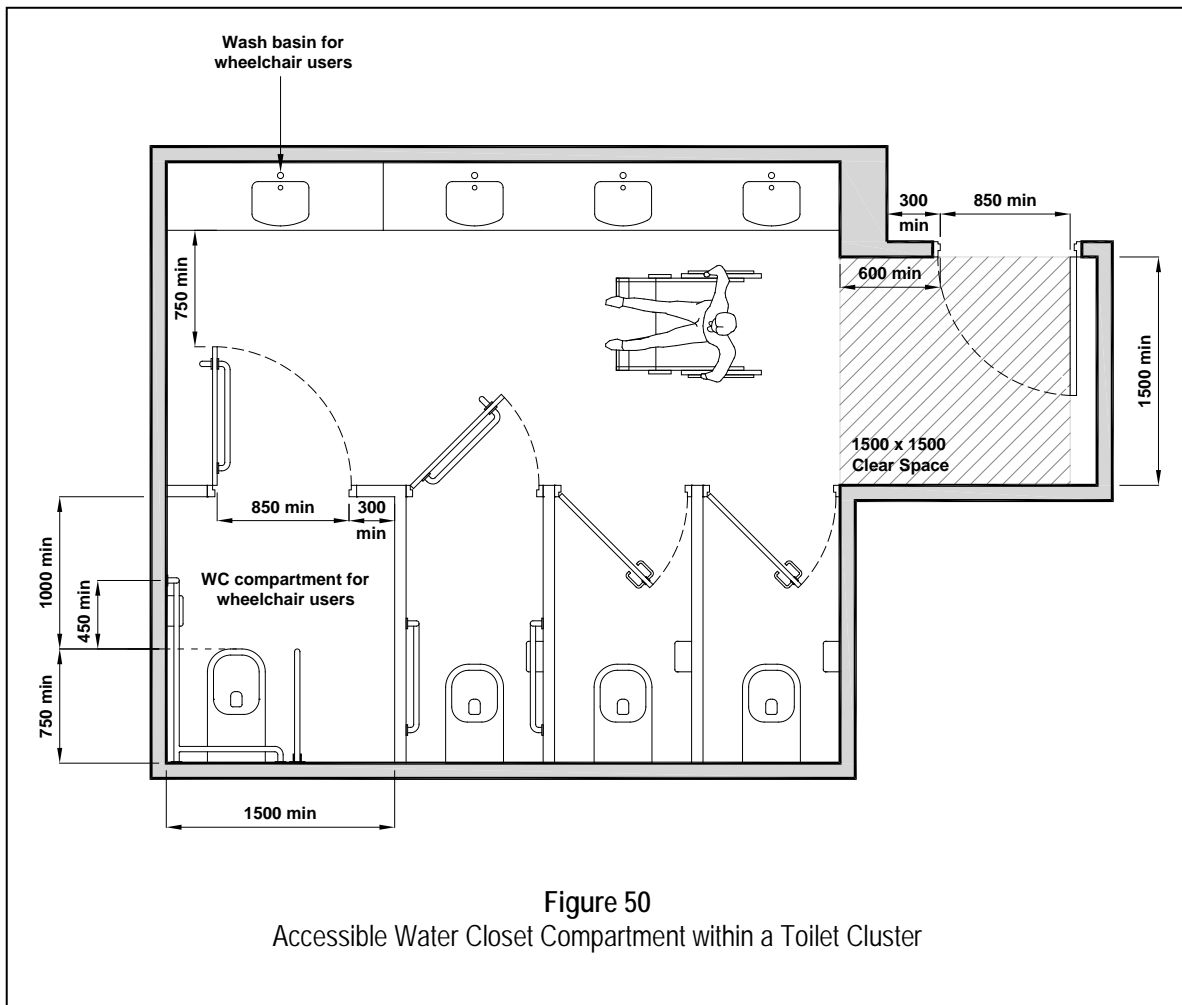
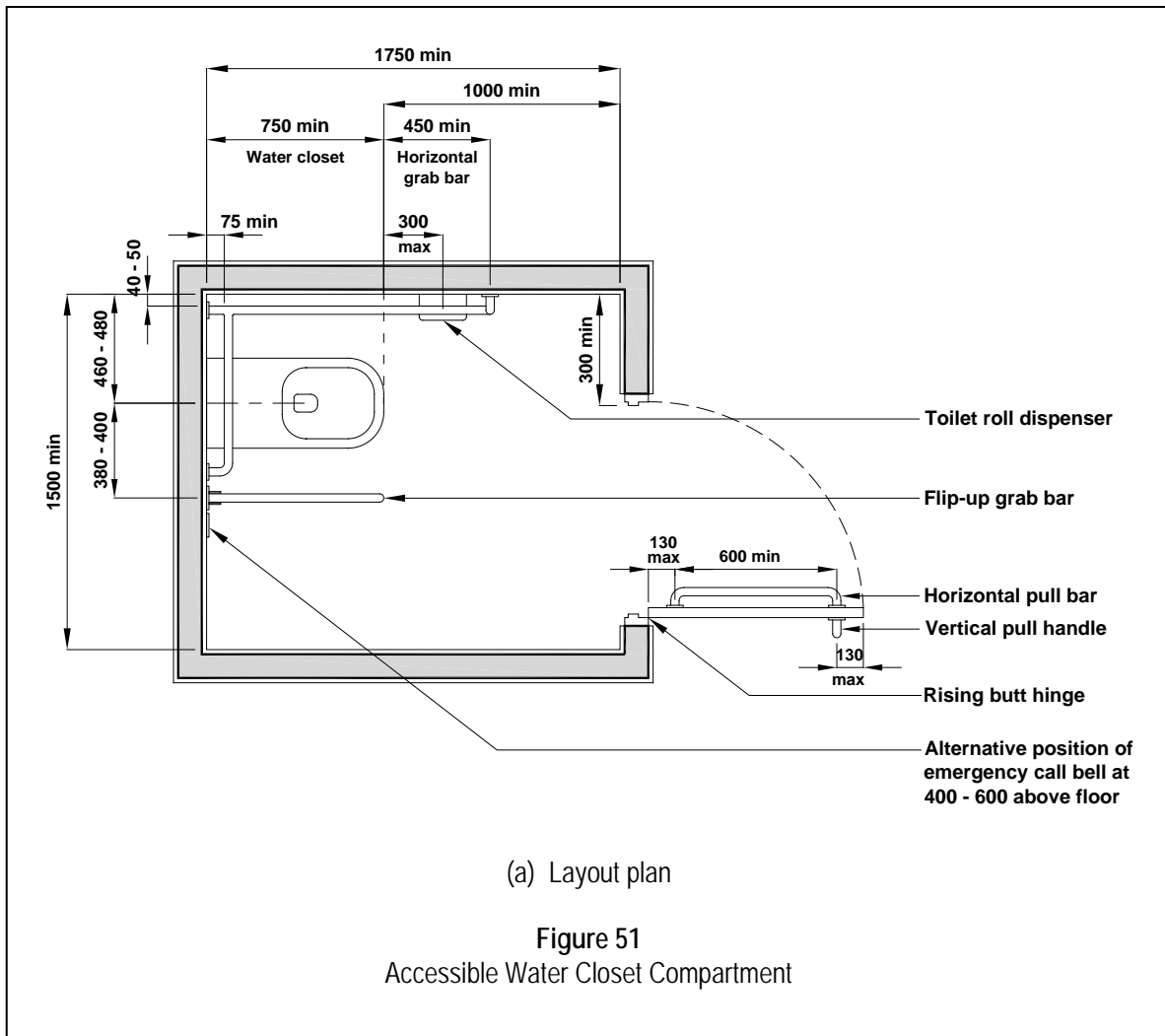
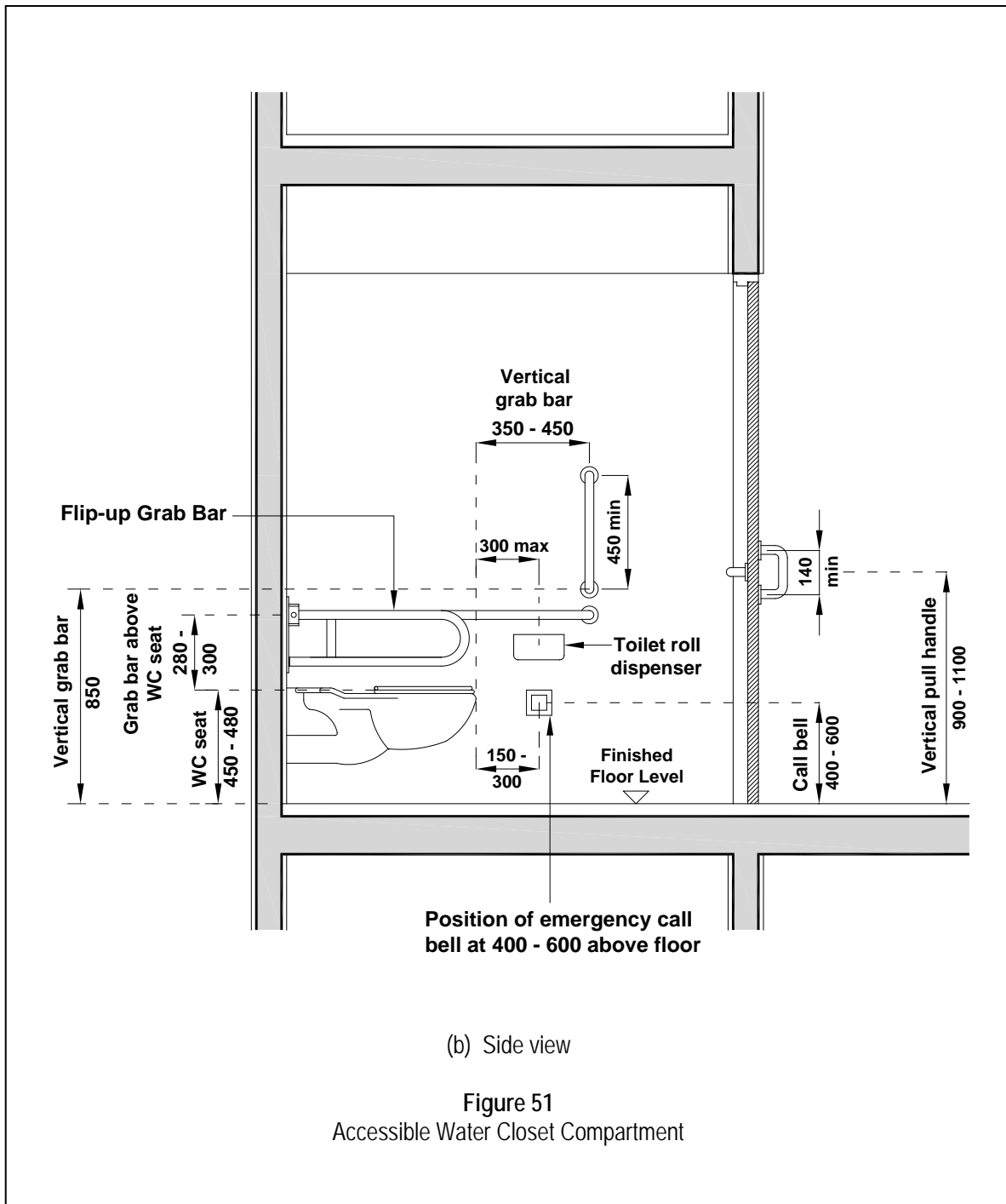
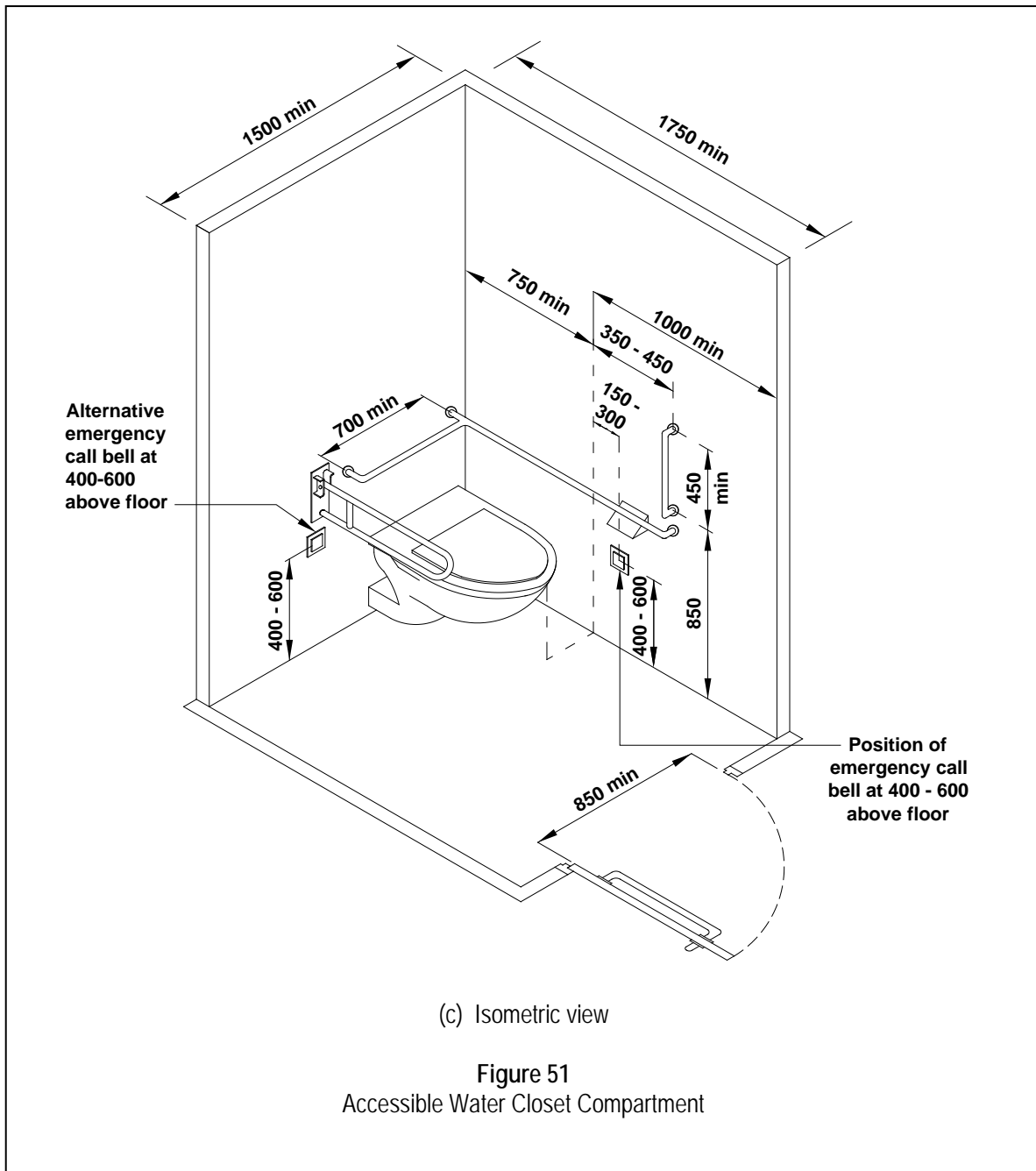

Figure 50
Accessible Water Closet Compartment within a Toilet Cluster



Note: *If obstructions such as pipe works are present, adjustment in the compartment size shall be made to meet the overall dimensions required.*





5.4 WATER CLOSET COMPARTMENTS FOR AMBULANT DISABLED

Ambulant disabled WC compartment

5.4.1 Water closet compartments for the ambulant disabled shall:

- (a) have internal dimensions of a standard compartment with a minimum width of 900 mm;
- (b) have grab bars on both sides of the compartment to act as handhold for ambulant user to stand as illustrated in Figure 52.

5.4.2 Water closet compartments for ambulant disabled shall be equipped with a door that provides a clear opening of at least 800 mm.

- 5.4.3 The door shall:
- (a) be designed to be either:
 - (i) a sliding/folding door in accordance with clause 4.4.4; or
 - (ii) swing outwards and in accordance with clause 5.6.1.1 (c) and (d);
or
 - (iii) swing inwards with a minimum clear space of 500 mm diameter from the edge of the water closet;
 - (b) be capable of being locked from the inside by a device that is operable with one hand and which does not require:
 - (i) fine finger control;
 - (ii) tight grasping; and
 - (iii) pinching or twisting of the wrist;
 - (c) have a sign for ambulant disabled sign placed on the outside of the door indicating that the compartment is suitable for use by persons who require grab bars.

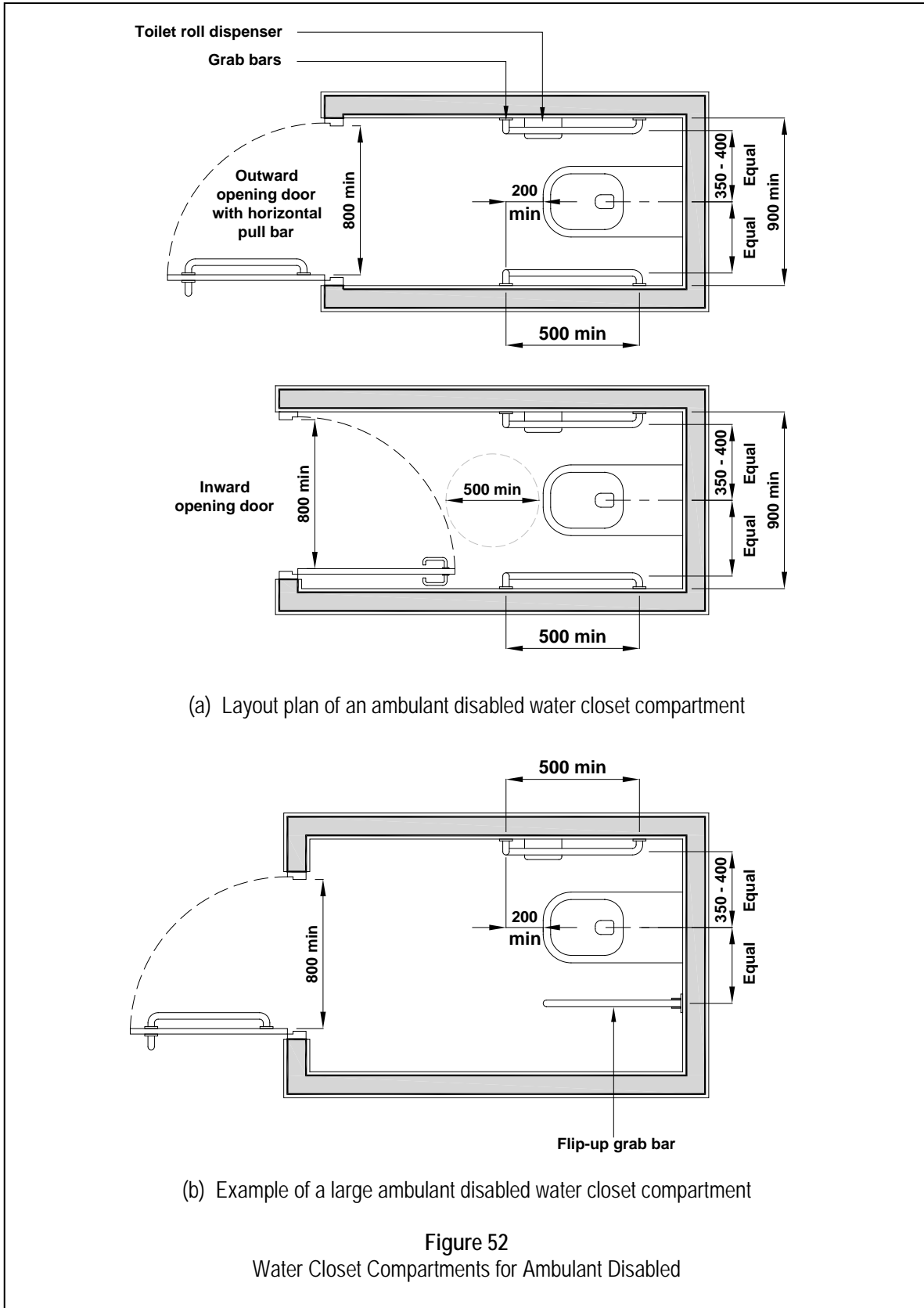

Note: *If obstruction such as pipe works is present, adjustment in the compartment size shall be made to meet the overall dimensions required.*

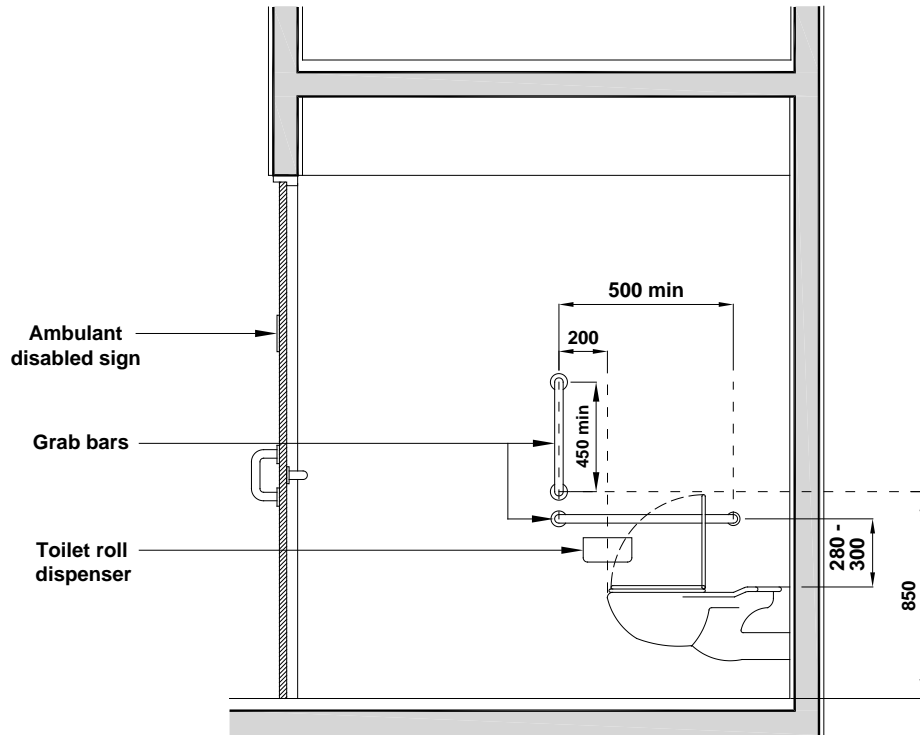

(c) Side view of ambulant disabled water closet compartment

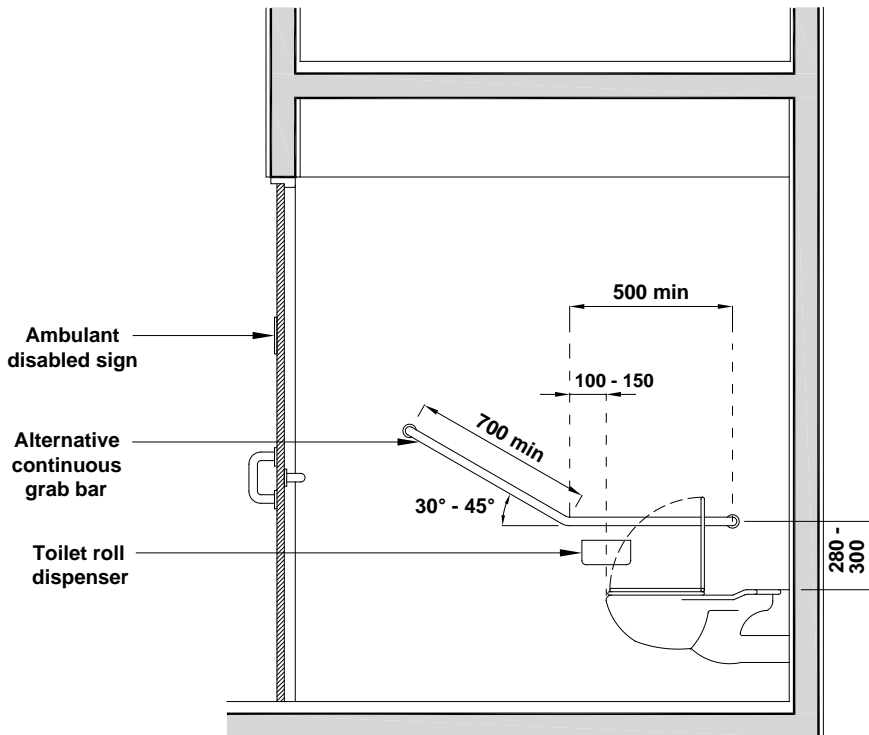

(d) Alternative grab bar arrangement of ambulant disabled water closet compartment

Figure 52
Water Closet Compartments for Ambulant Disabled

- Note:
- (1) *Water closet compartments for the ambulant disabled shall not be taken as alternatives to accessible individual washroom or accessible water closet compartments.*
 - (2) *Toilet roll holders should be located at a reachable range and not interfere with the use of grab bars.*
 - (3) *The wall construction and the fixings used to support the grab bars shall be capable of resisting the loads exerted by users.*

5.5 URINALS FOR THE AMBULANT DISABLED

Ambulant disabled urinals

5.5.1 Urinals for the ambulant disabled as illustrated in Figure 53 shall:

- (a) be of the wall-hung type with a rim of 500 mm or less from the floor;
- (b) have a minimum clear floor space of 750 mm wide by 1200 mm deep from grab bars location and without steps in front of the urinals; and
- (c) privacy shields, if provided, shall not extend beyond the front edge of the urinal rim.

5.5.2 Grab bars, complying with clause 4.7, shall be provided on both sides of the urinals as illustrated in Figure 53 and shall:

Urinal grab bars

- (a) have a minimum length of 600 mm with the lower point of the grab bar located at the maximum height of 800 mm from floor level;
- (b) have a clear space of 150 mm from internal corner or obstruction;
- (c) have a clear space of 120 mm between the grab bar and wall surface or privacy shields; and
- (d) be mounted at the same height and have a distance of between 500 mm and 650 mm.

5.5.3 Where urinals for the ambulant disabled are provided in a compartment with door provision, the compartment door shall comply with clause 5.4.2 and 5.4.3.

5.5.4 Flush controls shall:

- (a) comply with clause 6.2; and
- (b) be located at 1200 mm or less from the floor.

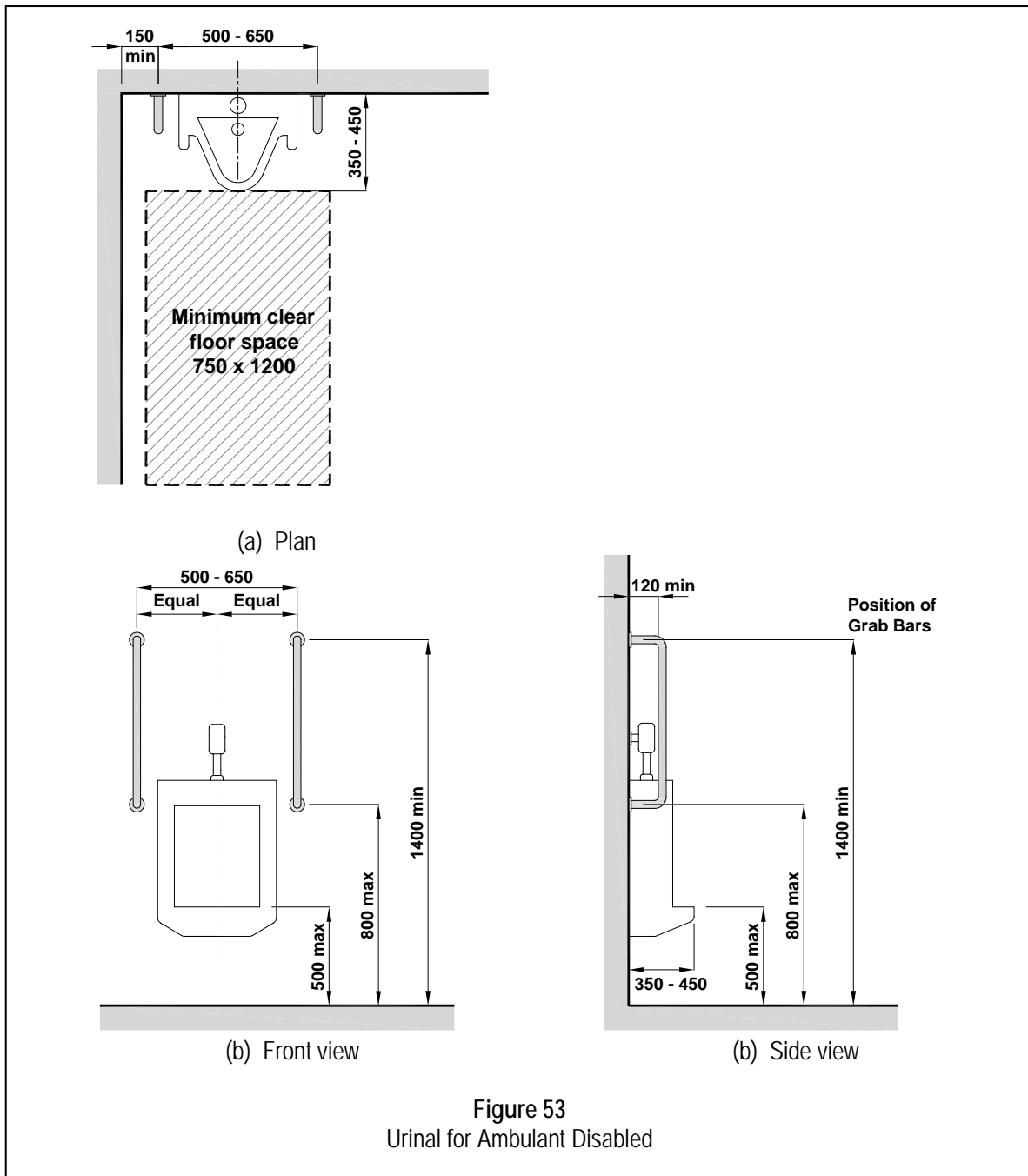

5.6 COMPONENTS IN THE ACCESSIBLE WASHROOM

5.6.1 Accessible Individual Washrooms And Accessible Water Closet Compartment Doors

5.6.1.1 Doors to accessible individual washrooms and accessible water closet compartments shall:

- (a) swing outwards or be designed as a sliding/folding door;

Accessible individual washroom and accessible water closet compartment doors

- (b) have a minimum clear opening of 850 mm or more in the fully open position in accordance with clause 4.4.2;
- (c) be provided with a horizontal pull-bar with a diameter between 19 mm to 45 mm that is:
 - (i) at least 600 mm long on the inside of an out-swinging door;
 - (ii) located so that it is 130 mm or less from the hinged-side of the door; and
 - (iii) fixed at a height between 900 mm and 1100 mm.
- (d) be provided with a vertical/horizontal pull-handle/bar with a diameter of between 19 mm to 45 mm that is:
 - (i) at least 140 mm long on the outside near the latch side of the door;
 - (ii) located so that the pull-handle is 130 mm or less from the latch side of the door; and
 - (iii) placed at a height between 900 mm and 1100 mm.
- (e) be capable of being locked from the inside by a device that is operable with one hand and activated by a force not more than 22N and which does not require:
 - (i) fine finger control;
 - (ii) tight grasping; and
 - (iii) pinching or twisting of the wrist.

Note:

- (1) *Accessible toilet doors shall be designed to open outwards so that it would be easier for a rescuer to enter a compartment if a person has fallen and is lying behind the door. To allow for assistance in case of emergency, locks and latches should allow the door to be opened from the outside with a coin or any simple device.*
- (2) *Wherever possible and practicable, a power-operated sliding door with button control should be considered as it is easier to operate and manoeuvre around the doorway.*

5.6.2	Grab Bars	Grab bars
5.6.2.1	<p>Grab bars shall be provided in accessible individual washrooms or water closet compartments as illustrated in Figures 48 and 51 and shall comply with the following requirements:</p> <ul style="list-style-type: none"> (a) be in accordance with clause 4.7; (b) be mounted at a height between 280 mm and 300 mm from the top of the water closet seat; (c) one horizontal grab bar to be mounted on the side wall closest to the water closet extending from the rear wall to at least 450 mm in front of the water closet seat; (d) one flip-up grab bar to be mounted on the wide side of the compartment adjacent to the water closet; (e) one vertical bar to be provided on the side wall closest to the water closet and located between 350 mm and 450 mm from the front edge; and (f) one horizontal grab bar of at least 700 mm long, to be mounted on the wall behind the water closet. 	
5.6.2.2	<p>The flip-up grab bar specified in clause 5.6.2.1 (d) shall be able to remain in a vertical position when not in use. When lowered from the wall, it shall:</p> <ul style="list-style-type: none"> (a) be at a height between 280 mm and 300 mm from the top of the water closet seat and at the same height as the grab bar mounted at the side; (b) extend not more than 100 mm from the front of the water closet seat; (c) have the length of not less than 100 mm away from the front of the water closet seat; and (d) be 380 mm to 400 mm to the centre line of the water closet. 	Flip-up grab bar
Note:	<i>Unless otherwise specifically stated, all measurements shall be to the centre line of the bar.</i>	

5.6.3 Washroom Accessories

Washroom accessories

5.6.3.1 Washroom accessories shall comprise the following:

- (a) a mirror, with the bottom edge positioned at a height of 1000 mm or less from the floor as shown in Figure 54; and
- (b) Paper towel dispensers or hand dryers, soap dispensers, litter bins and other washroom accessories shall contrast in colour and tone and be positioned such that the operable parts and controls are between 900 mm and 1200 mm from the floor.

- Note:
- (1) Accessories should be placed in close proximity to the accessible basin to avoid having a person wheeling a chair with wet hands.
 - (2) The lighting should be fixed in such a position that it does not shine directly onto the mirror.

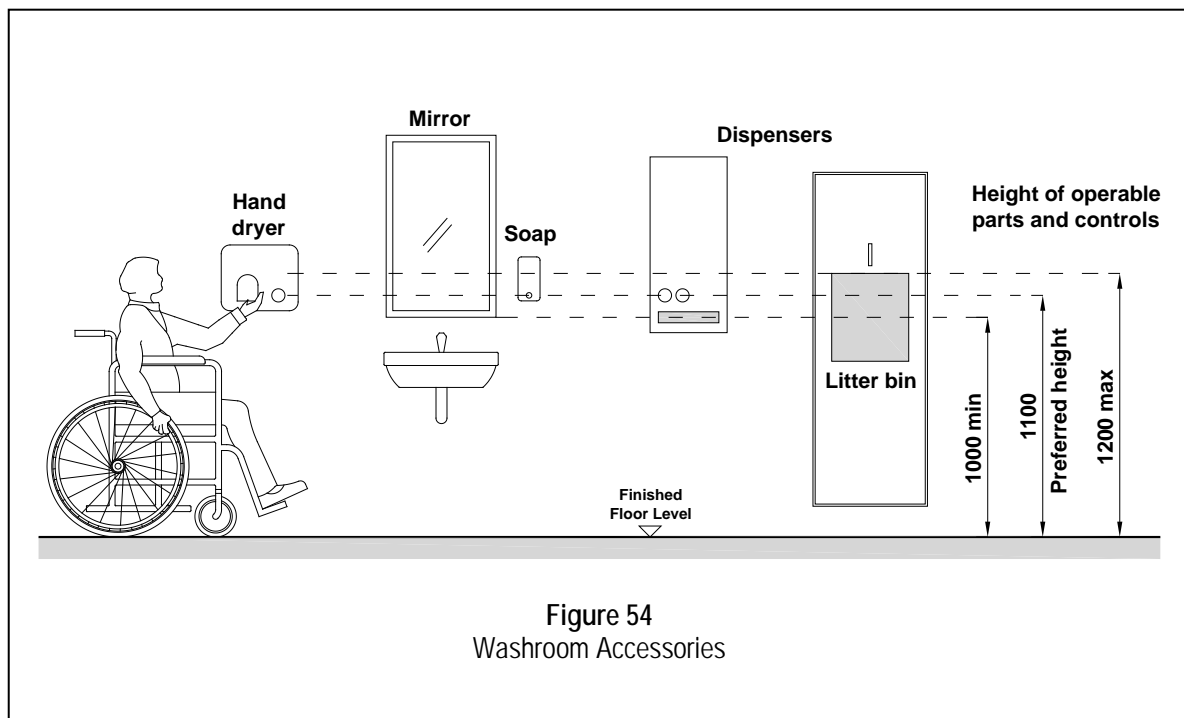

5.6.4 Emergency Call Bells

Emergency call bells

5.6.4.1 An emergency call bell shall be provided in:

- (a) an accessible individual washroom compartment; or
- (b) an accessible water closet compartment; or
- (c) bath facilities within the accessible room.

5.6.4.2 The emergency call bell shall be equipped with a waterproof push-button or pull-chord for activating the bell.

5.6.4.3 The push-button or pull-chord shall:

- (a) be located at a height between 400 mm to 600 mm above the floor level and located between 150 mm to 300 mm from either the front or side edges of the water closet as illustrated in Figures 48 (c) and 51 (c);
- (b) be located at a height between 400 mm to 600 mm above the floor level adjacent to the bathtub as illustrated in Figure 57 (a) and 58 (a); and
- (c) have a colour that is contrasting with the background.

5.6.4.4 Emergency call bells shall be provided to alert caregivers or responsible persons in a management office. The call annunciation shall, where appropriate, be provided by:

- (a) a call bell located outside the accessible toilet; or
- (b) a buzzer in the caregiver's office; or
- (c) an emergency call bell located outside the accessible room or a buzzer to the management office.

5.6.4.5 A notice stating "Emergency Call" shall be prominently affixed next to the push-button or pull-chord.

5.6.5 Wash Basin

Wash basin

5.6.5.1 Wash basins, as illustrated in Figure 55, shall:

- (a) not interfere with the manoeuvring space of wheelchair users while transferring to the water closet;
- (b) be mounted such that the minimum distance between the centre line of the fixture and the side wall is 460 mm;
- (c) be mounted such that the top edge is between 800 mm and 840 mm from the floor;
- (d) have a knee space of at least 750 mm wide by 200 mm deep by 680 mm high with an additional toe space of at least 750 mm wide by 230 mm deep by 230 mm high; and

(e) have a minimum clear floor space of 750 mm wide by 1200 mm deep of which a maximum of 480 mm in depth may be under the wash basin.

5.6.5.2 The hot water and drain pipes located within the knee or toe space shall be properly insulated.

5.6.5.3 Taps and other controls provided shall comply with clause 6.2.

5.6.5.4 Where vanity counters are provided, all dimensions related to height, circulation, knee and toe spaces as specified for basins shall comply with clauses 5.6.5.1 to 5.6.5.3.

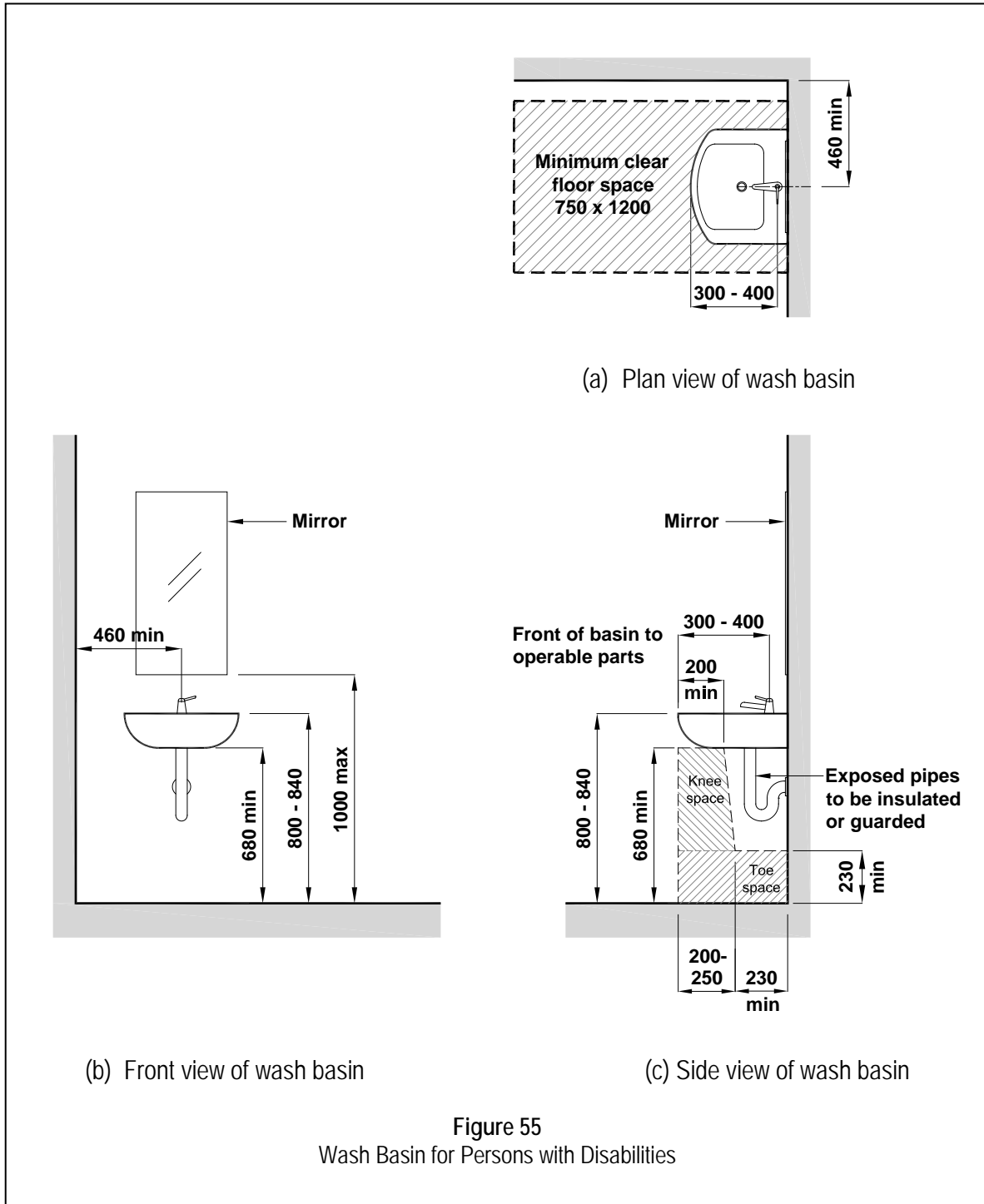

5.6.6 Water Closets

Water closets

5.6.6.1 Water closets as shown in Figure 56 shall comply with the following requirements:

- (a) be located between 460 mm to 480 mm from the centre line of the water closet to the adjacent wall and have a clear dimension of 750 mm from the front edge of the water closet to the rear wall to facilitate side transfer;

- (b) the top of the water closet seat shall be between 450 mm and 480 mm from the floor as shown in Figures 48 (b) and 51 (b);
- (c) have no spring-activated seats;
- (d) have a back support where there is no seat lid or water cistern as shown in Figure 56 (b). A back support reduces the chance of imbalance or injury caused by leaning against exposed valves or pipes;
- (e) have adequate space for the footrest of the wheelchair, needed while the user transfers from the wheelchair to the water closet;
- (f) have flush control:
 - (i) complying with clause 6.2;
 - (ii) if hand-operated, shall be located on the transfer side of the water closet; and
 - (iii) located at a height of between 800 mm to 1100 mm from the floor.

5.6.6.2 Pedestal-type water closets with cisterns as shown in Figure 56 (c) may be considered as an alternative approach to providing an accessible toilet for existing buildings in exceptional circumstances.

- Note:
- (1) *Preferences for toilet seat heights vary considerably. Higher seats may be an advantage to some ambulant disabled but a disadvantage to wheelchair users. Toilet seats at a height of 450 mm offer a reasonable compromise. Thick seats and filler rings are available to adapt standard fixtures to these requirements.*
 - (2) *Major problems are encountered by wheelchair users entering and leaving a washroom. Within the washroom, sufficient space is required to allow wheelchair users to move freely to and from the various fixtures as shown in Figure 48 (a).*

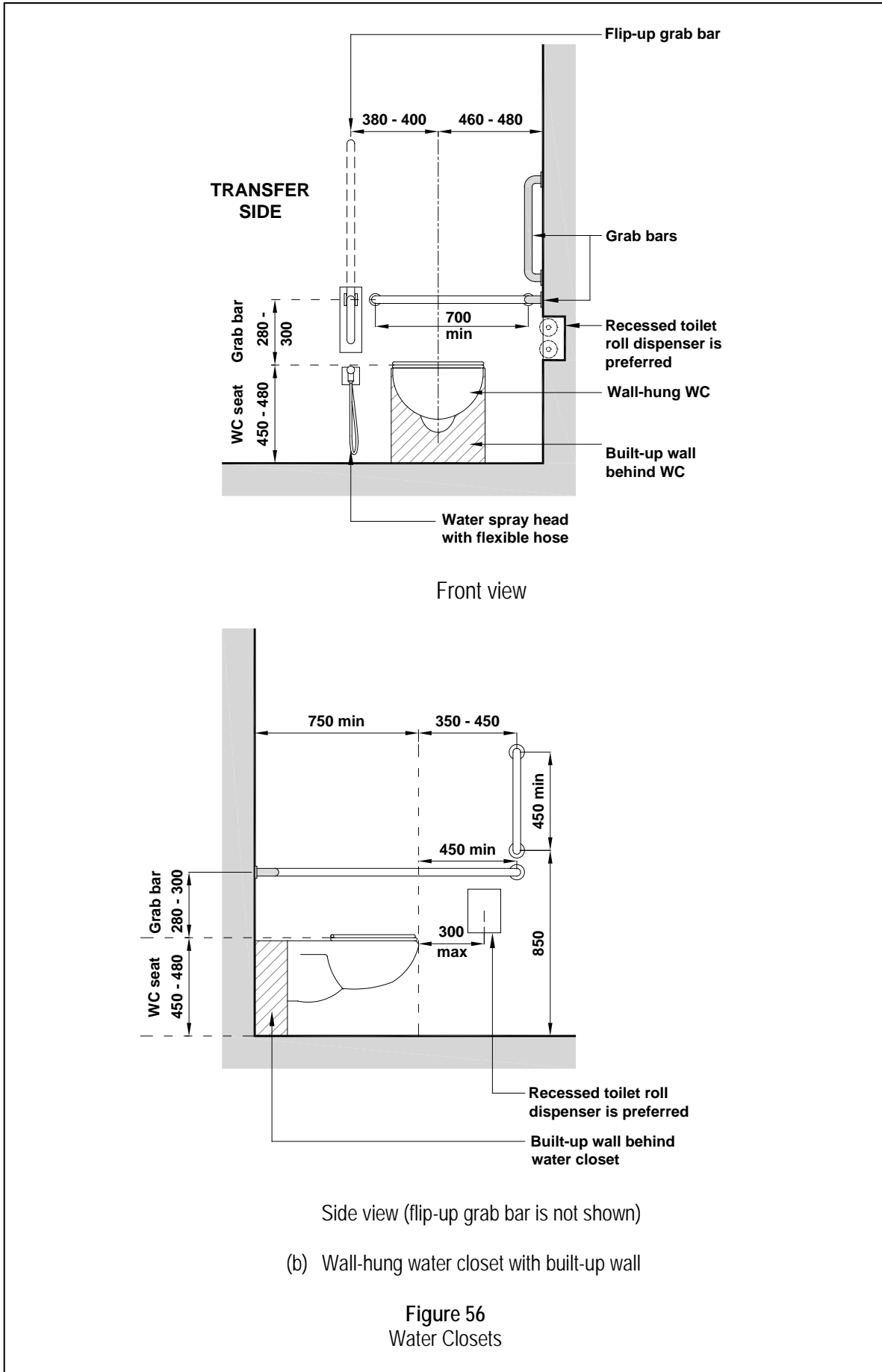

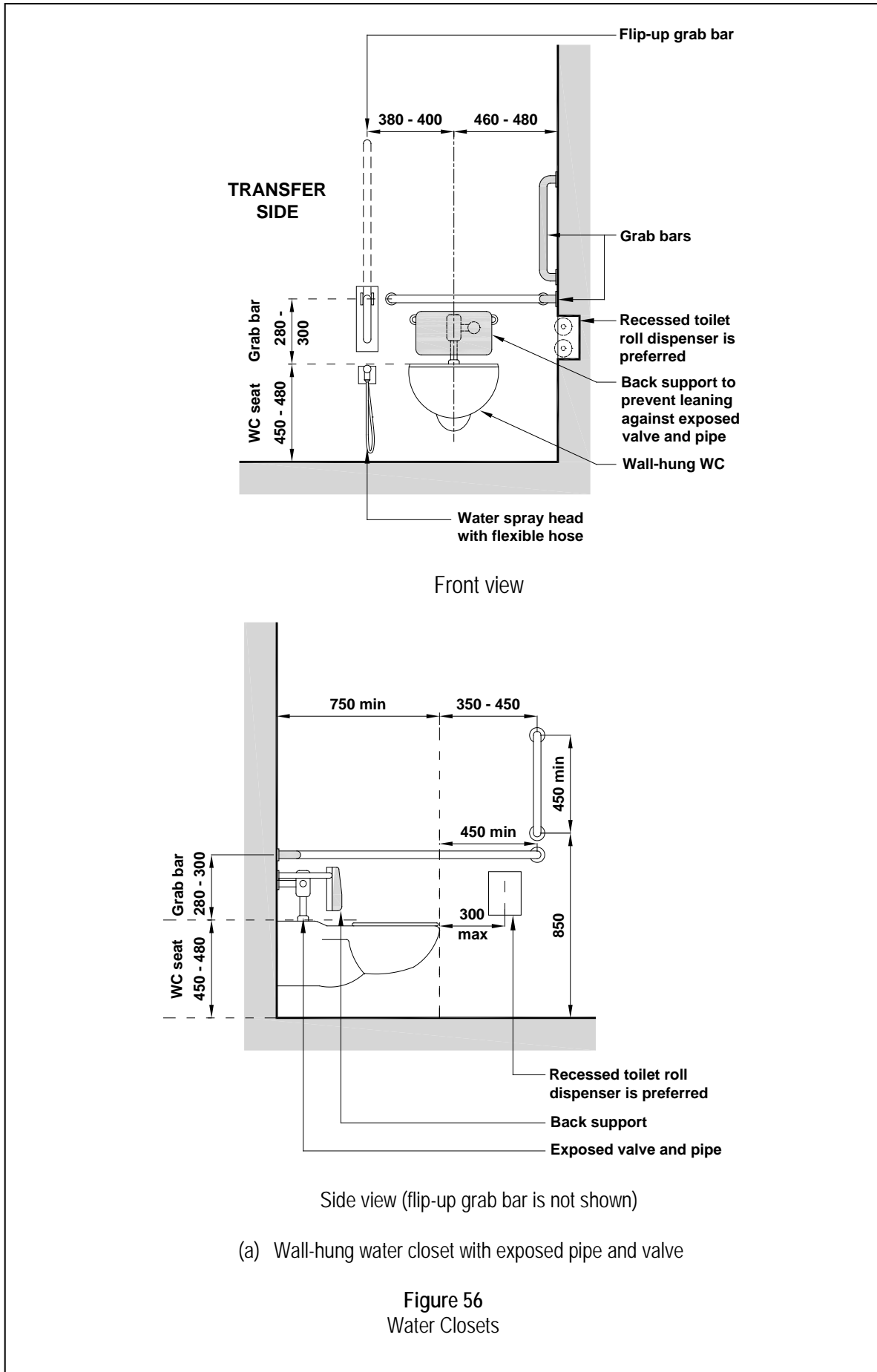

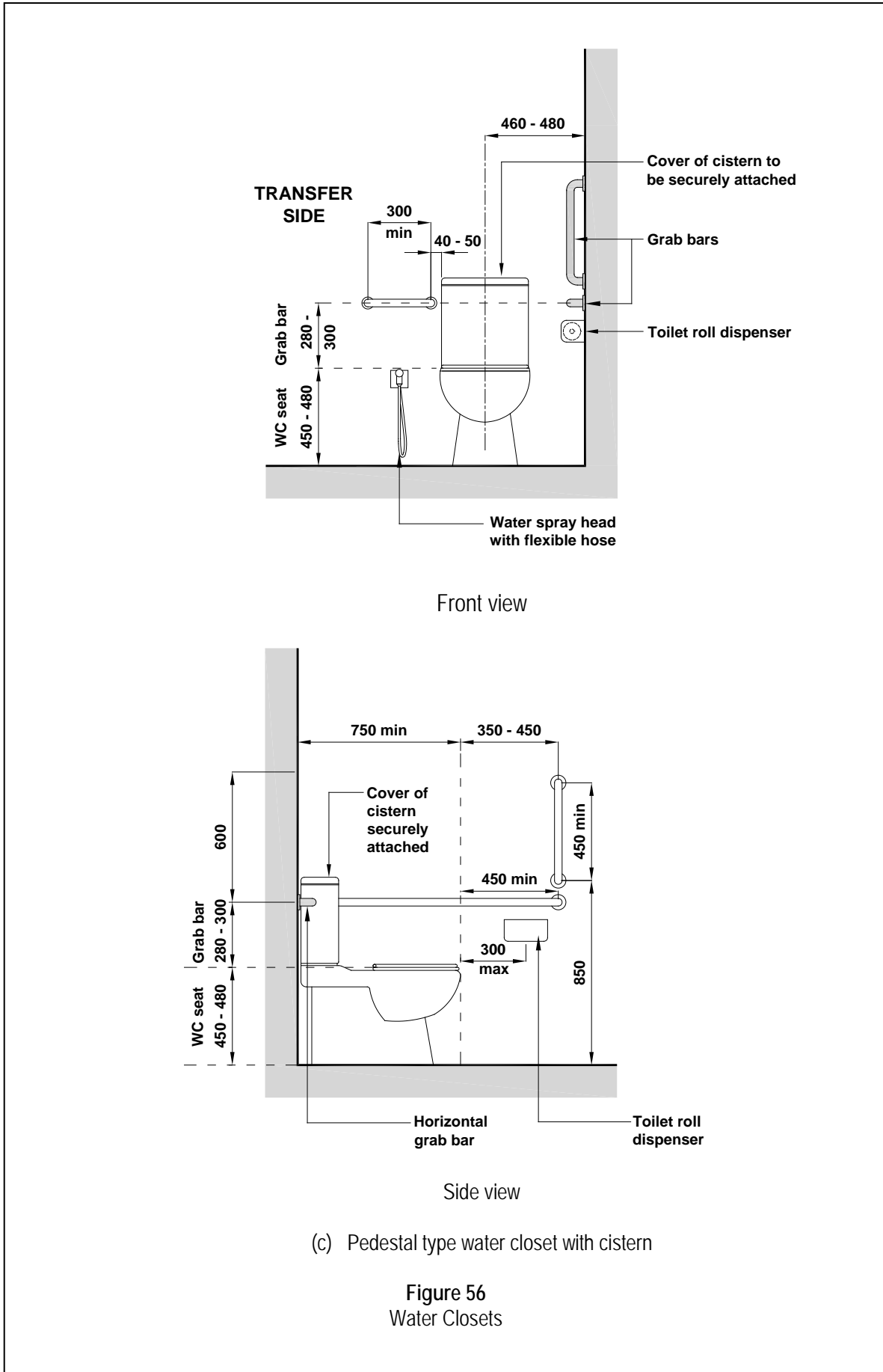

5.6.7	Motion Sensor Lighting	Motion sensor lighting
5.6.7.1	<p>Where motion sensor-type lighting switches are used within the accessible individual washroom or toilet compartment, they shall comply with the following:</p> <p>(a) switch controllers are equipped for fail-safe operation;</p> <p>(b) illumination timers are set for a minimum of 30-minute duration; and</p> <p>(c) the sensor shall be appropriately located and easily activated by any occupant movement in the toilet.</p>	
5.7	BATH FACILITIES	Bath facilities
5.7.1	General	Scope
5.7.1.1	Hotels or boarding houses, serviced apartments and hostels, halls of residence or dormitories which are required to have accessible provisions for persons with disabilities as stipulated in Chapter 2, shall be provided with bathtubs complying with clause 5.7.2 or shower stalls complying with clause 5.7.3.	
5.7.1.2	Sports complexes and public swimming pools which are required to have accessible provisions for persons with disabilities as stipulated in Chapter 2, shall be provided with at least one accessible individual shower facility complying with clause 5.7.3 at each level of the shower facilities provided. Where two or more clusters of shower facilities are provided at the same level but at different locations, the accessible individual shower facility may be replaced with an accessible shower within the male and female shower areas provided that there is at least one accessible individual shower facility on the same level.	
5.7.2	Bathtub	Bathtub
5.7.2.1	There shall be a clear floor space of at least 900 mm by 1500 mm in front of the bathtub. The wash basin may encroach to a maximum of 300 mm into this space, provided there is a clear knee and toe space under the wash basin.	
5.7.2.2	The bathtub shall be provided with a seat of at least 250 mm wide along its entire length and at a height of between 450 mm to 480 mm.	
5.7.2.3	The base of the bathtub shall be slip-resistant and, where it is not possible, a slip-resistant rubber mat shall be provided.	

- 5.7.2.4 The layout of a bathtub is illustrated in Figure 57.
- 5.7.2.5 Grab bars for bathtubs shall:
- (a) comply with clause 4.7;
 - (b) be at least 1200 mm long, located horizontally along the length of the bathtub and 180 mm to 280 mm above the bathtub rim; and
 - (c) be at least 1200 mm long, located vertically at the control end of the bathtub adjacent to the clear floor space with the lower end 180 mm to 280 mm above the bathtub rim as shown in Figure 57 (c).
- 5.7.2.6 The bathtub shall be equipped with an emergency call bell in accordance with clause 5.6.4.
- 5.7.2.7 As an alternative to clause 5.7.2.2, a seat of at least 400 mm deep, across its width shall be provided. The seat shall be located at the opposite end of the controls to allow for easier access as illustrated in Figure 58 (a).

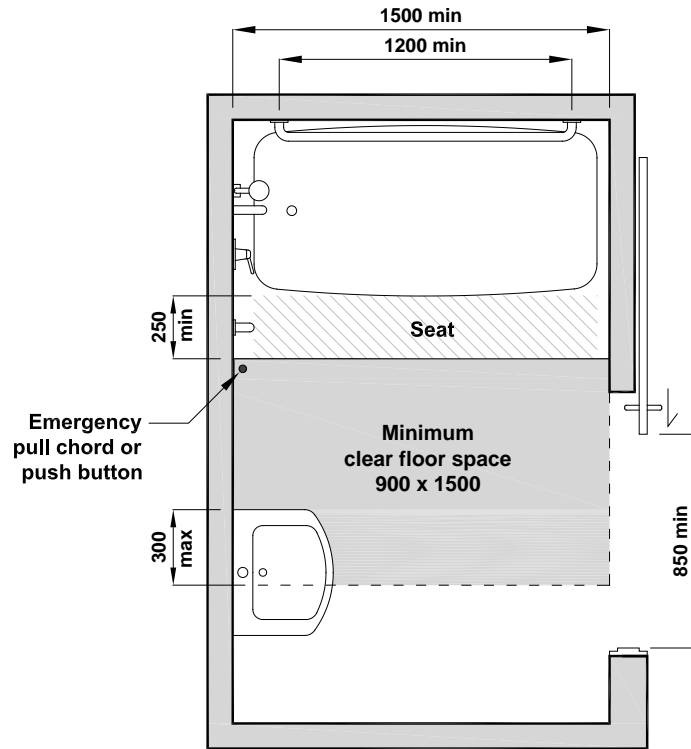

(a) Layout plan of bathtub

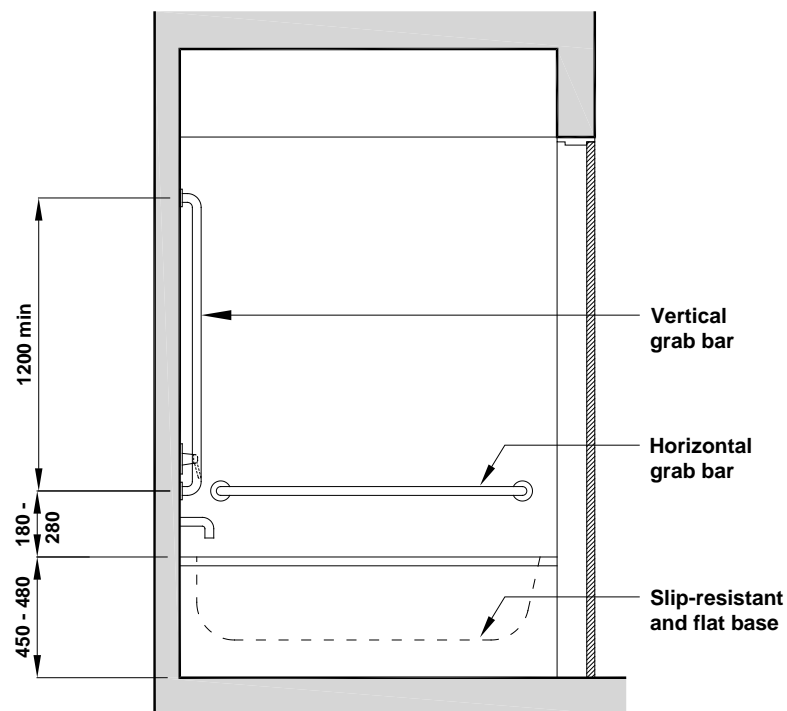

(b) Side view of bathtub

Figure 57
Bathtub for Persons with Disabilities

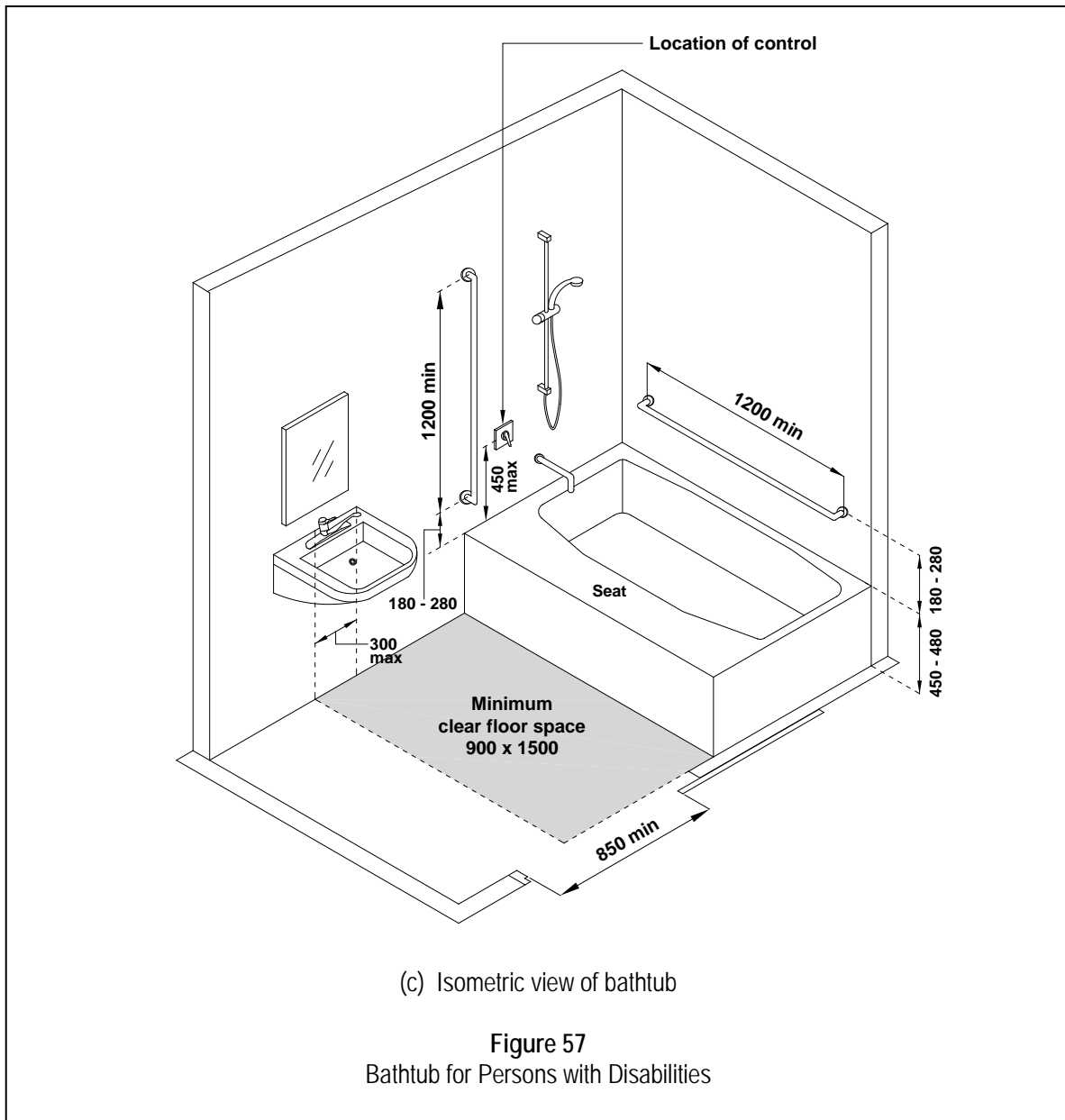

- Note:
- (1) Tap controls should be located close to the outside of the bathtub for ease of access by persons in wheelchairs.
 - (2) Bathtub provision is not encouraged as older persons and persons with disabilities prefer to use roll-in shower for bathing.

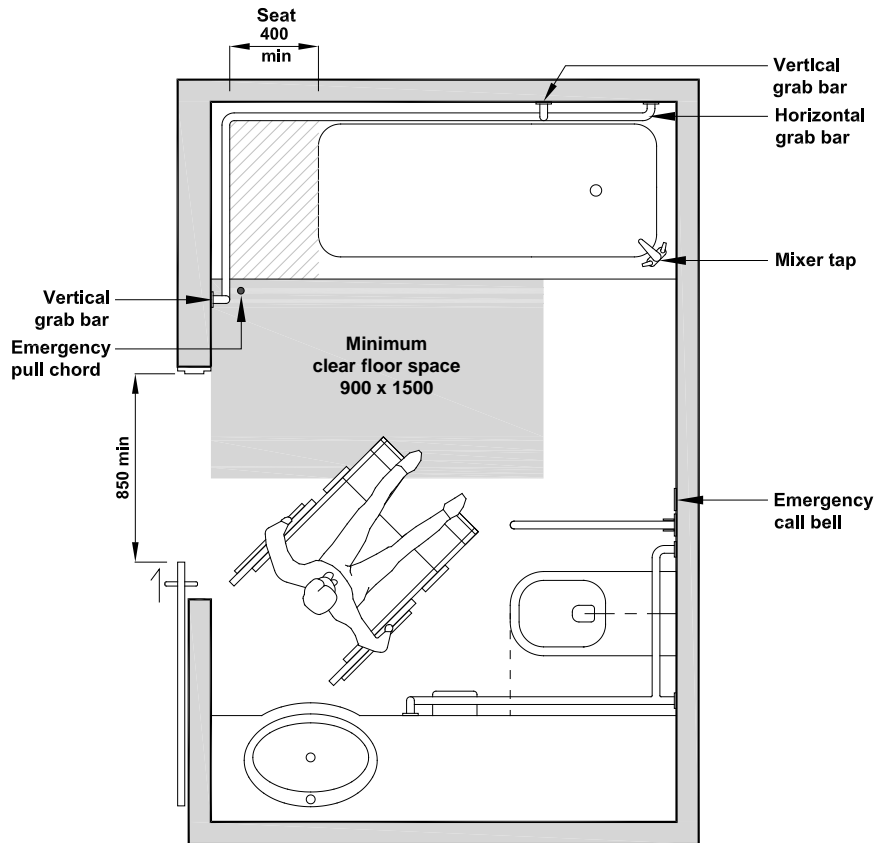

(a) Layout plan of bathtub

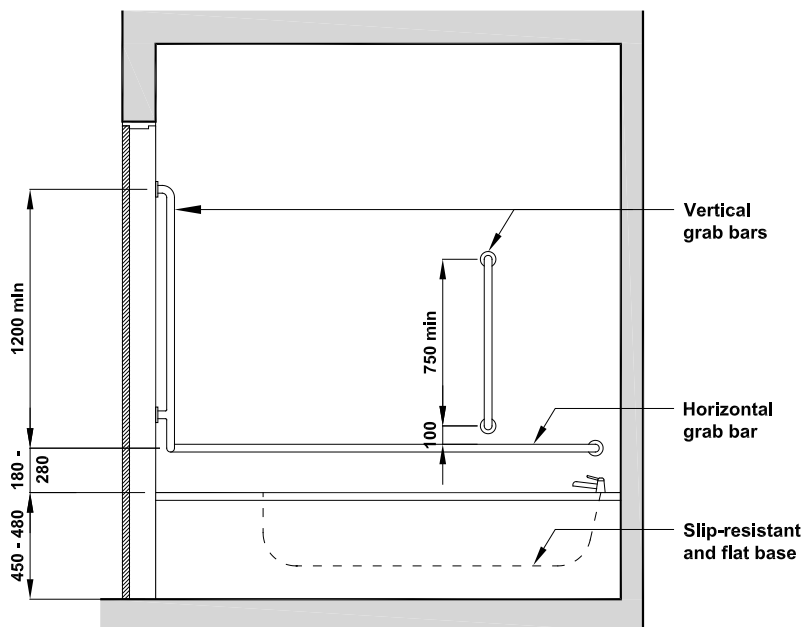

(b) Side view of bathtub

Figure 58
Alternative Layout Plan of Bathroom for Persons with Disabilities

- | | | |
|-----------|--|---|
| 5.7.3 | Roll-in Shower Stall for Wheelchair Users | Shower stall |
| 5.7.3.1 | General | |
| 5.7.3.1.1 | A roll-in shower stall shall have internal dimensions of at least 1500 mm by 1500 mm as shown in Figure 59. | |
| 5.7.3.1.2 | The minimum clear floor space in front of the shower entrance shall be 900 mm by 1500 mm parallel to the shower entrance. | |
| 5.7.3.1.3 | Where an accessible individual washroom is designed to include shower facilities, the minimum internal dimensions shall be 2000 mm by 1750 mm as shown in Figure 60. | Accessible individual washroom with shower facility |
| 5.7.3.1.4 | The floor of the roll-in shower stall shall be slip-resistant. | |
| Note: | <i>Additional information and guidance on slip-resistant finishes are given in Appendix F.</i> | |
| 5.7.3.1.5 | Enclosures for shower stalls shall comply with clause 5.7.4.3. | |

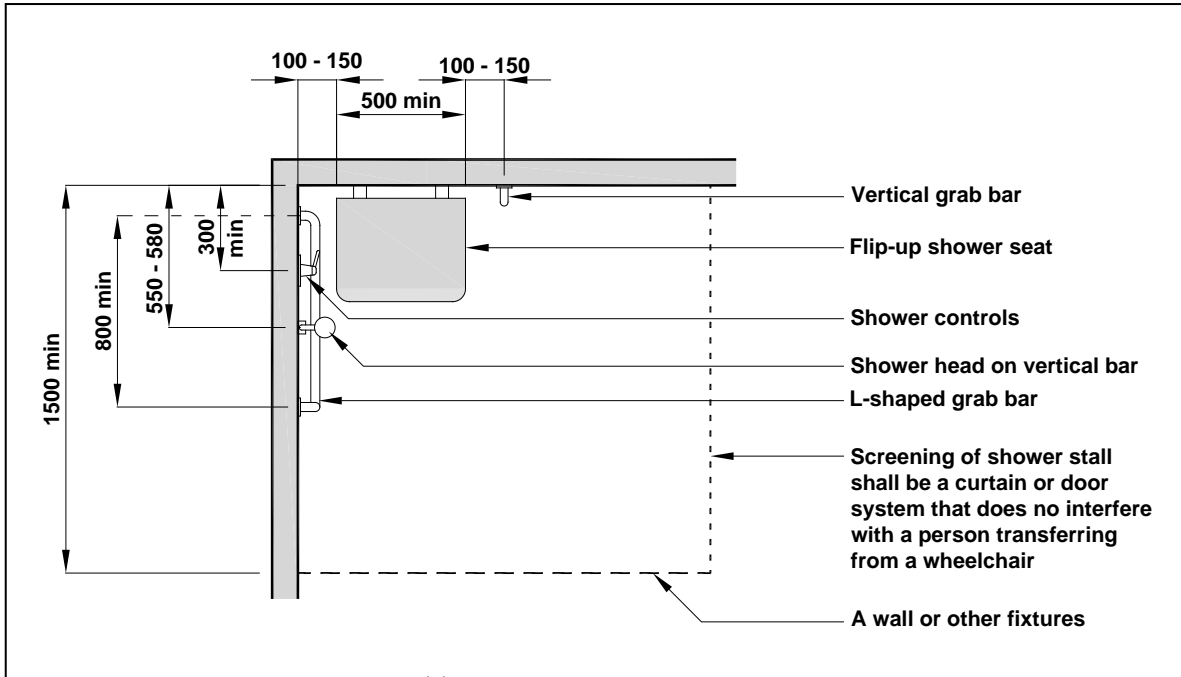

(a) Layout plan of roll-in shower stall

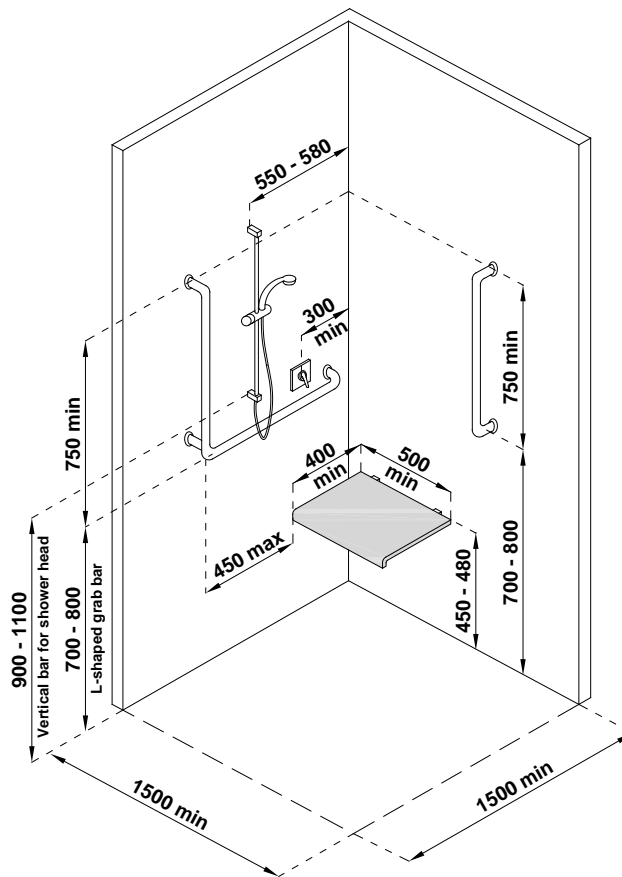

(b) Isometric view of roll-in shower stall

Figure 59
Roll-in Shower Stall for Wheelchair Users

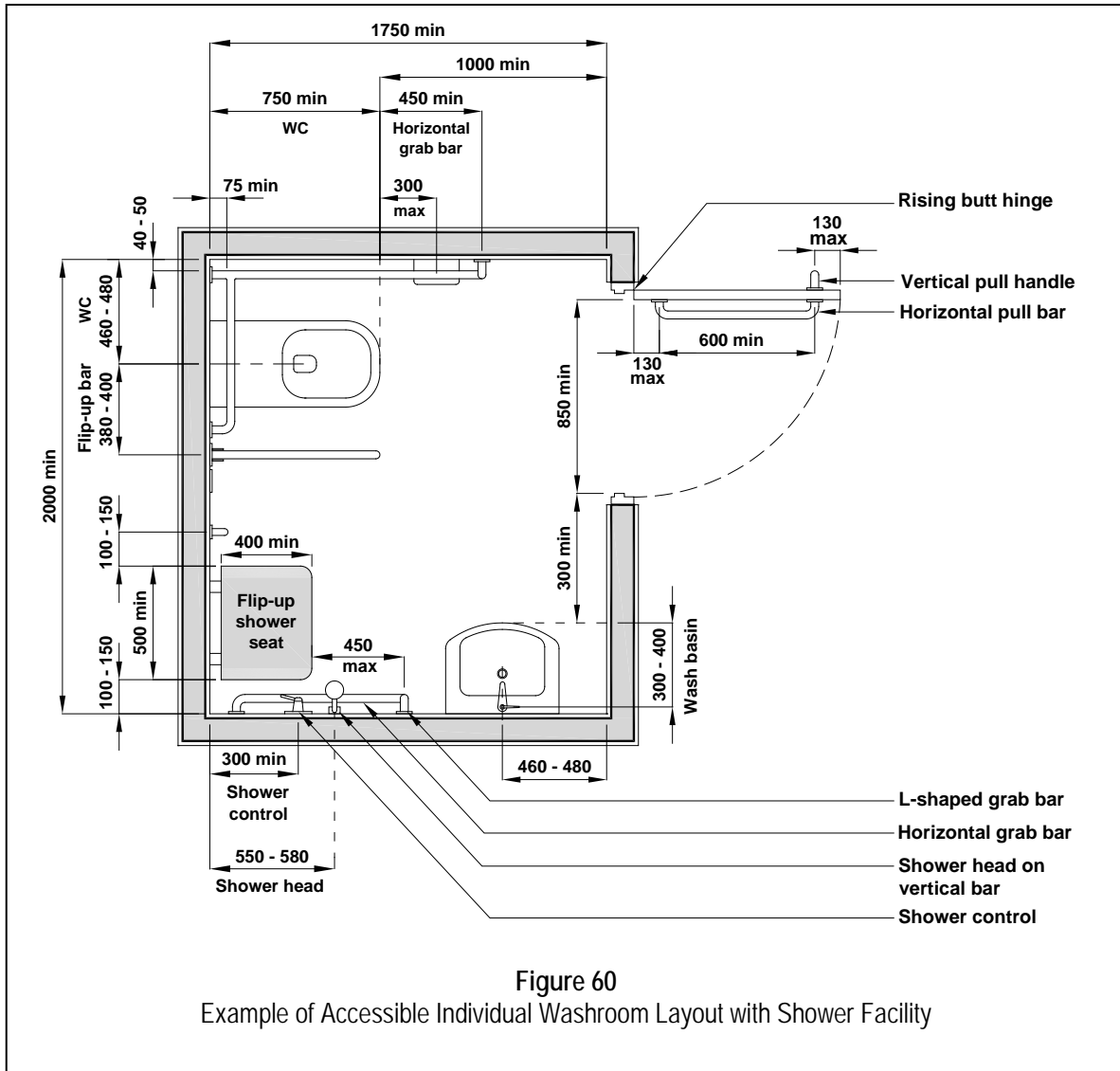

5.7.3.2 Grab bars for roll-in shower stall

5.7.3.2.1 Grab bars for roll-in shower stalls as shown in Figure 59 shall:

- (a) comply with clause 4.7;
- (b) comprise of an L-shaped bar or 2 bars arranged in a L-shaped configuration of at least 750 mm by 800 mm, mounted between 700 mm and 800 mm from the shower floor and not more than 450 mm from the edge of shower seat; and
- (c) have a vertical bar of at least 750 mm mounted between 100 mm and 150 mm from the shower seat.

5.7.3.3 Kerbs for roll-in shower stalls

5.7.3.3.1 Kerbs for roll-in shower stalls shall:

- (a) not be more than 10 mm high, bevelled at a slope of 1:2; and
- (b) have colours that contrast with the flooring colour to reduce the possibility of dangerous tripping.

5.7.3.4 Shower seat

5.7.3.4.1 The shower seat shall:

- (a) have a rounded edge, self-draining and slip-resistant;
- (b) be installed on the wall nearest to the controls;
- (c) have the minimum dimensions of 500 mm wide by 400 mm deep for use in either a roll-in shower or an accessible individual washroom with shower facility as shown in Figure 59 or Figure 60;
- (d) have its top between 450 mm and 480 mm from the floor;
- (e) have grab bars comply with the requirements of clause 5.7.3.2; and
- (f) have fastenings for grab bars and construction for the foldable seat which are able to withstand a force of 1.3KN applied at any position and in any direction.

Note: *If a roll-in shower stall is attached to a room, it is possible for a wheelchair user to use the bed to help him to dress. However, the length of the seat in an accessible individual washroom with shower facilities needs to be longer as the wheelchair user needs the additional space to facilitate his dressing.*

5.7.4 Bathroom Components for Bathtubs and Rolls in Showers

Bath
components

5.7.4.1 Taps and controls

Taps and
controls

5.7.4.1.1 Taps and other controls shall:

- (a) comply with clause 6.2 for both bathtub and shower stalls;
- (b) be located at the control end of the bathtub between the centre line and to the outer edge;
- (c) be 450 mm or less above the bathtub rim as shown in Figure 56 (c); and

- (d) have clearly visible colour contrast and embossed signs indicating hot and cold water supply.

5.7.4.2 **Shower heads** Shower heads

5.7.4.2.1 Shower heads used in bathtubs and shower stalls shall:

- (a) be of the hand-held type;
- (b) be provided with a hose 1500 mm long or more; and
- (c) allow for use in a fixed position.

5.7.4.2.2 Where shower heads are mounted on a vertical bar, the bar shall:

- (a) have a minimum length of 500 mm with the lower end located between 900 mm to 1100 mm above the floor level; and
- (b) be installed so as not to obstruct the use of grab bars.

5.7.4.3 **Bath enclosures** Bath enclosures

5.7.4.3.1 Enclosures for bathtubs and roll-in showers shall not:

- (a) obstruct controls;
- (b) interfere with a person transferring from a wheelchair; and
- (c) have tracks mounted on the bathtub rim or edges of shower pans or the shower area.

5.8 **WHEELCHAIR TRANSFER** Wheelchair transfer

5.8.1 **Diagonal approach**

5.8.1.1 The diagonal approach for wheelchair transfer is as illustrated in Figure 61.

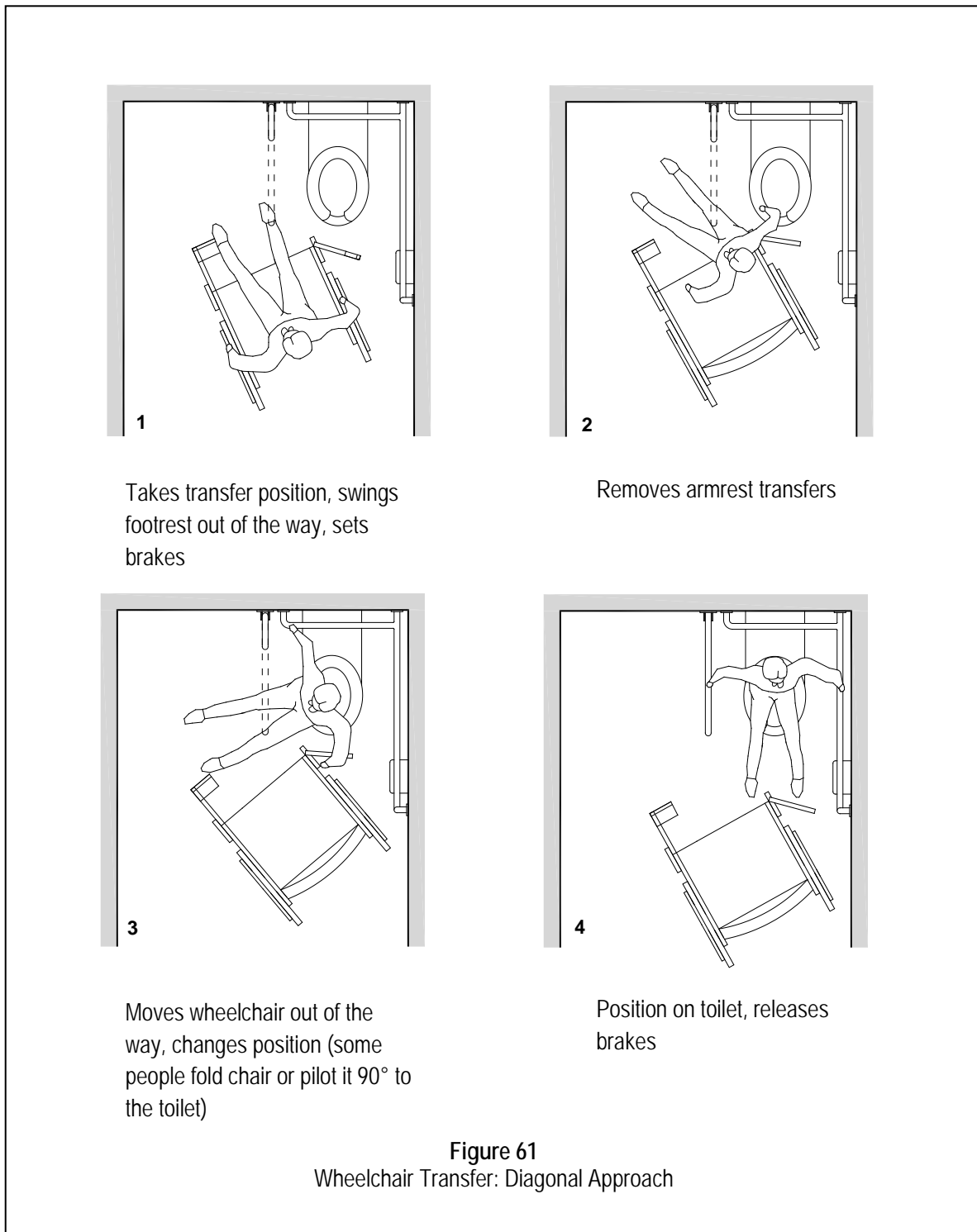

5.8.2 **Side approach**

5.8.2.1 The side approach for wheelchair transfer is as illustrated in Figure 62.

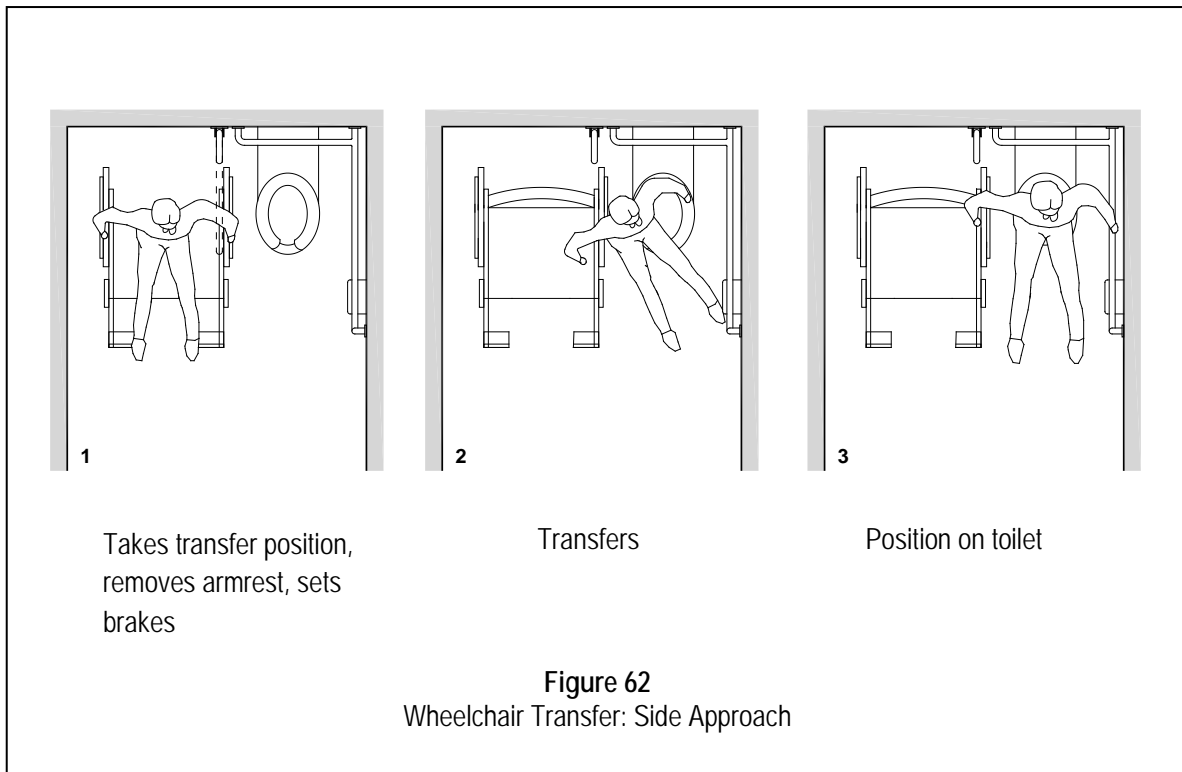

5.8.3 Frontal approach

5.8.3.1 The frontal approach for a wheelchair transfer is as illustrated in Figure 63.

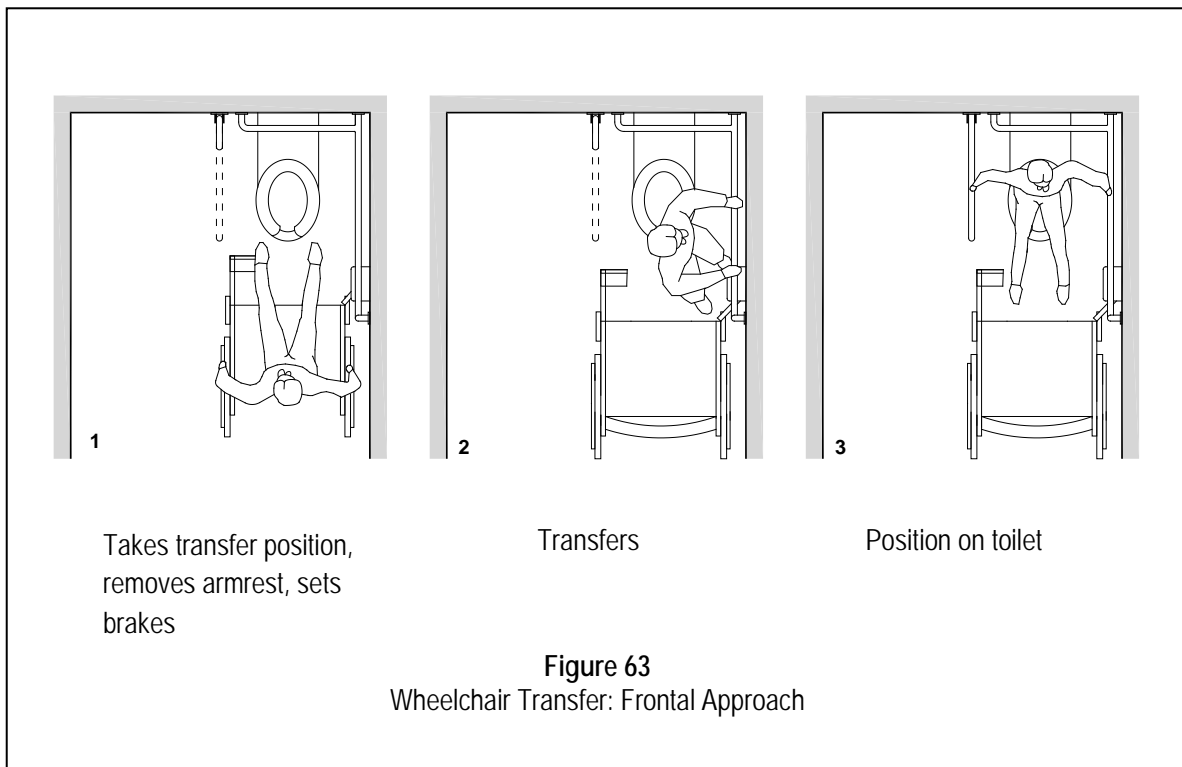

CHAPTER 6

USAGE OF SPACE, FACILITIES AND ELEMENTS WITHIN THE BUILDING

Objective : Usage of Space, Facilities and Elements

Building services and facilities such as electrical controls, sockets outlets and switches, information counters, public telephones, seats and tables shall be accessible and usable by all people. For buildings that are frequently accessed by families, appropriate facilities shall be provided to serve the needs of nursing women, young children and their caregivers.

- | | | |
|---|---|----------------|
| ▪ | Illumination | CI 6.1 |
| ▪ | Controls and Operating Mechanisms | CI 6.2 |
| ▪ | Seating Spaces | CI 6.3 |
| ▪ | Service and Information Counters | CI 6.4 |
| ▪ | Drinking Fountains | CI 6.5 |
| ▪ | Public Telephones | CI 6.6 |
| ▪ | Eating Spaces | CI 6.7 |
| ▪ | Hearing Enhancement Systems | CI 6.8 |
| ▪ | Family-Friendly Facilities | CI 6.9 |
| ▪ | Accessible Rooms, Guestrooms and Serviced Apartments | CI 6.10 |

6.1	ILLUMINATION	Illumination
6.1.1	Lighting shall be uniform. Extreme differences in the level of brightness should be avoided.	
6.1.2	Lights shall be acceptably bright but should not cause glare or shadows that would give rise to optical illusions.	
6.1.3	Ceiling-mounted light fittings with diffusers shall be positioned longitudinally at the centre of the accessible route.	
6.1.4	Controls and operating mechanisms should be capable of being illuminated to at least a level of 100 lux.	

6.2	CONTROLS AND OPERATING MECHANISMS	Controls and operating mechanism
6.2.1	Floor Space	
6.2.1.1	A clear and level floor space of at least 900 mm by 1200 mm should be provided at controls, operating mechanisms such as dispensers and receptacles designated for use by persons with disabilities.	
6.2.2	Electrical Controls and Sockets Outlets	Electrical controls and outlets
6.2.2.1	The design and construction of the operating controls and devices should aim to ensure the independent and safe operation of controls and devices by intended users.	
6.2.2.2	The operating controls and devices include but are not limited to: <ul style="list-style-type: none"> (a) door handles and locks; (b) levers or mixer taps; (c) activation devices, vending machines and vehicle park auto-pay machines; (d) window openers and locks; and (e) electrical sockets outlets and switches. 	
6.2.2.3	The operable part of controls should be: <ul style="list-style-type: none"> (a) located adjacent to a clear floor space that has a minimum width of 900 mm; (b) located at a height of between 450 mm to 1200 mm from the floor level as shown in Figure 64; (c) operable by one hand; (d) of a type that does not require tight grasping, pinching or twisting of the wrist; and (e) operable with a force of 22N or less. 	Operable parts of controls

Note: *If light switches are provided for accessible individual washrooms or accessible water closet compartment, they should be located at a height of between 800 mm to 1200 mm.*

- | | | |
|---------|--|---|
| 6.2.2.4 | The key pads, card readers and intercom buttons should be provided at a height of between 800 mm and 1200 mm from the floor level. | Key pads, card readers and intercom buttons |
| 6.2.2.5 | The operating part of controls, electrical sockets and switches shall be located at 350 mm or more from the internal corner of a room or obstruction as shown in Figure 64 (c). | |
| 6.2.2.6 | Power-operated doors shall be either automatically controlled, for example, by a motion sensor, or manually activated by a control such as a push pad. | |
| 6.2.2.7 | Manual controls for power-operated doors should be distinguishable against the background and should not be located such that a person, having used the control, needs to move to avoid contact with the door as it opens. | |
| 6.2.2.8 | Controls for powered operated swing doors as shown in Figure 64 (d) shall: | Powered operated swing doors |
| | (a) be located at least 600 mm from the internal corner of a room or obstruction; | |
| | (b) have clear 1000 mm minimum distance from the swing of the arc of the door; and | |
| | (c) allow sufficient opening time for persons with mobility aids to pass through the door safely before it closes. | |
| 6.2.2.9 | The colours of controls and operating mechanisms should contrast with their backgrounds. | |

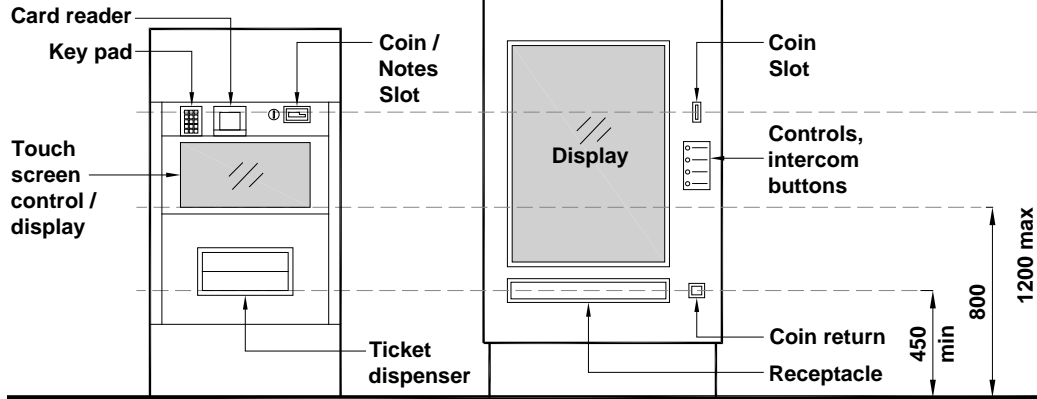

(a) Vending Machine / Vehicle Park Auto-Pay machine

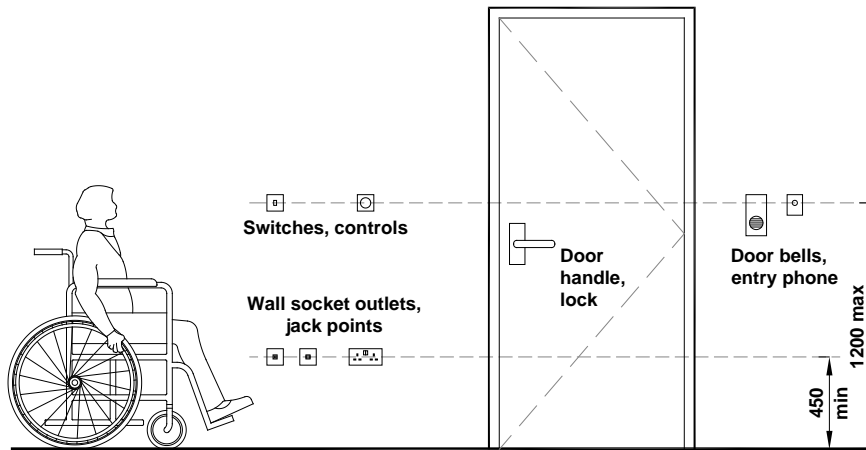

(b) Height of switches and socket outlets

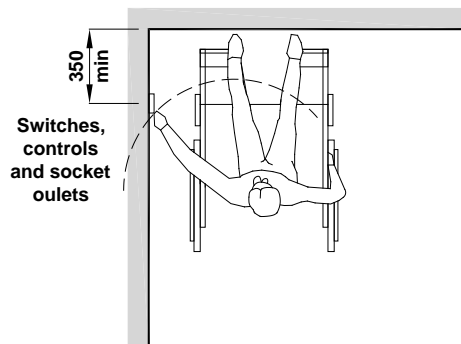

(c) Distance of switches, controls and sockets from the internal corner of a room

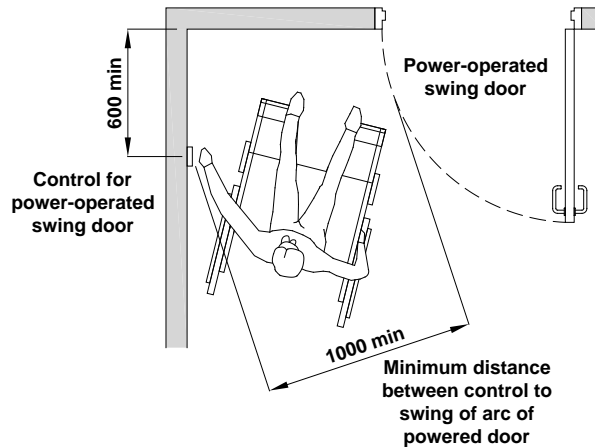

(d) Distance of control for power-operated swing doors at the internal corner of a room

Figure 64
Controls and Operating Mechanisms

6.2.3 Operation of taps and other controlsOperation of
taps and other
controls

6.2.3.1 Taps designated for use by persons with disabilities shall have levers or be sensor operated.

Note *Where wheelchair accessible wash hand basins are placed together with other basins for general use, the taps used shall be sensor-operated in accordance with NEA's Code of Practice for Environment Health.*

6.2.3.2 Hand-operated controls including taps shall:

- (a) be operable with one hand;
- (b) require no tight grasping, pinching or twisting of the wrist;
- (c) require a force of 22N or less to activate; and
- (d) have handles with levers (not self-closing) operable with a closed fist as shown in Figure 65.

6.2.3.3 The temperature of hot water supplied to the shower shall be controlled by a pressure-equalizing valve or by an automatic, thermostatically controlled valve.

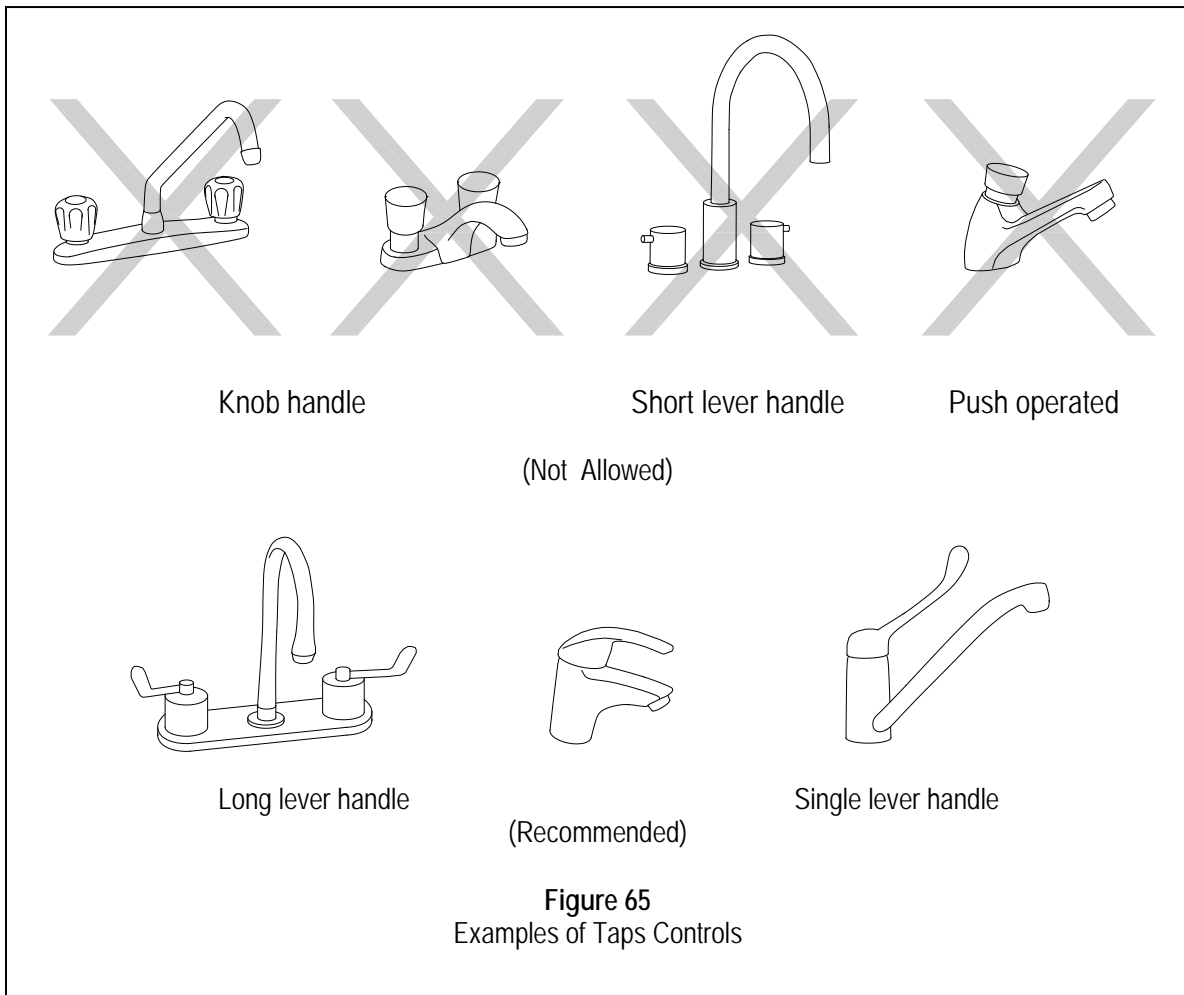

6.3 SEATING SPACES

Seating spaces

6.3.1 Clear Floor Space

6.3.1.1 Seating spaces, such as those provided at counters, tables or work surfaces and for wheelchair users shall have a clear floor space not less than 900 mm by 1200 mm.

6.3.1.2 Seating spaces for cinemas, theatres, concert halls, stadia or other places of public resort shall have clearly identified wheelchair spaces, each measuring at least 900 mm wide by 1200 mm deep as shown in Figure 66. Access to spaces for wheelchair users shall be direct and unobstructed.

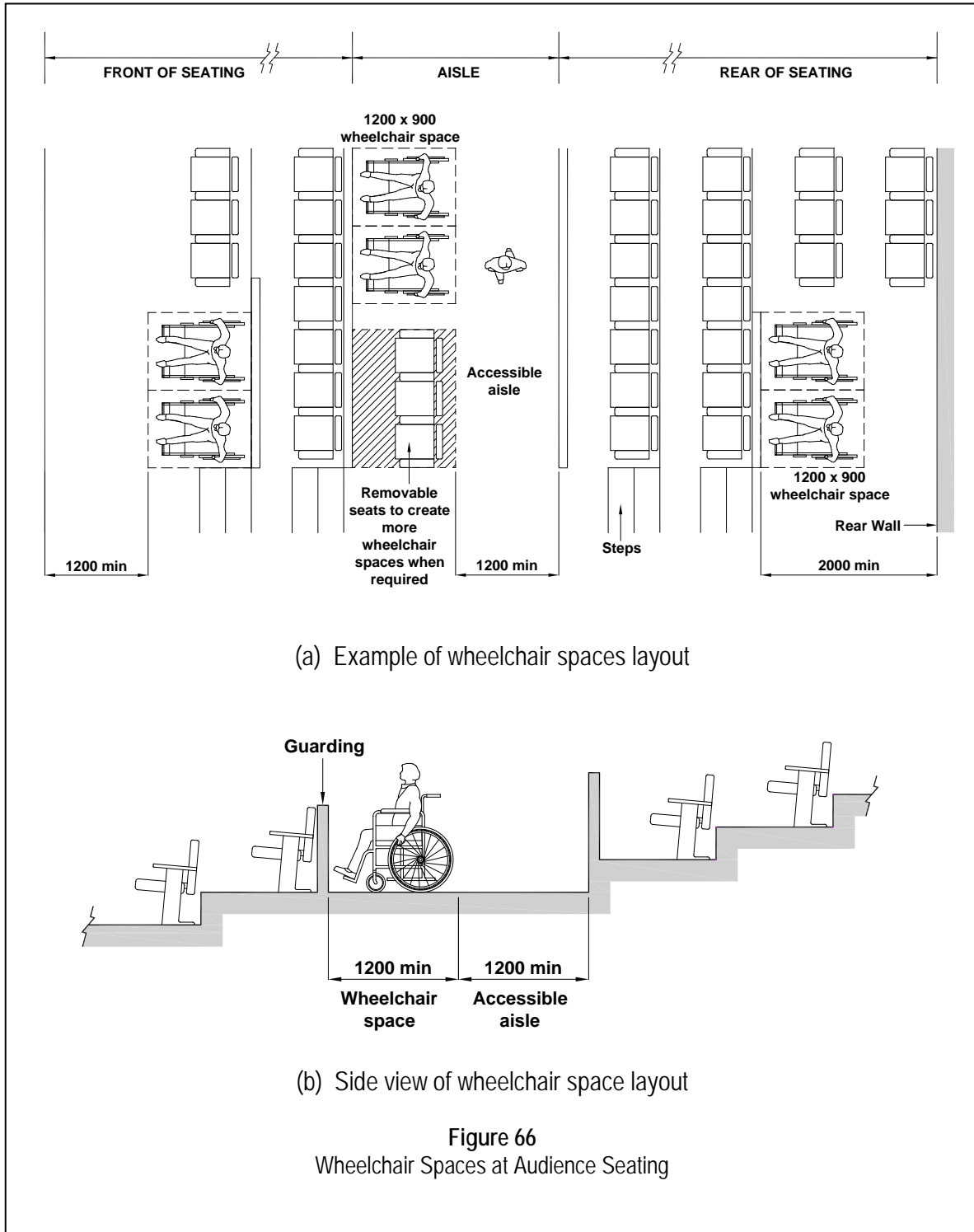

- Note:
- (1) *Wheelchair spaces shall be connected to accessible routes and should be located at different tiered seating similar to the regular seating provision.*
 - (2) *There should be good sight lines from all seating position so that viewers are able to see the speaker, a person assisting with sign language, projection screen, presentation, performance or sports event.*

6.3.2 Clear Knee Space

6.3.2.1 Where a forward approach is used, a clear knee space of at least 900 mm wide, 480 mm deep and 700 mm high shall be provided which may overlap the clear floor space by a maximum of 480 mm as shown in Figure 67.

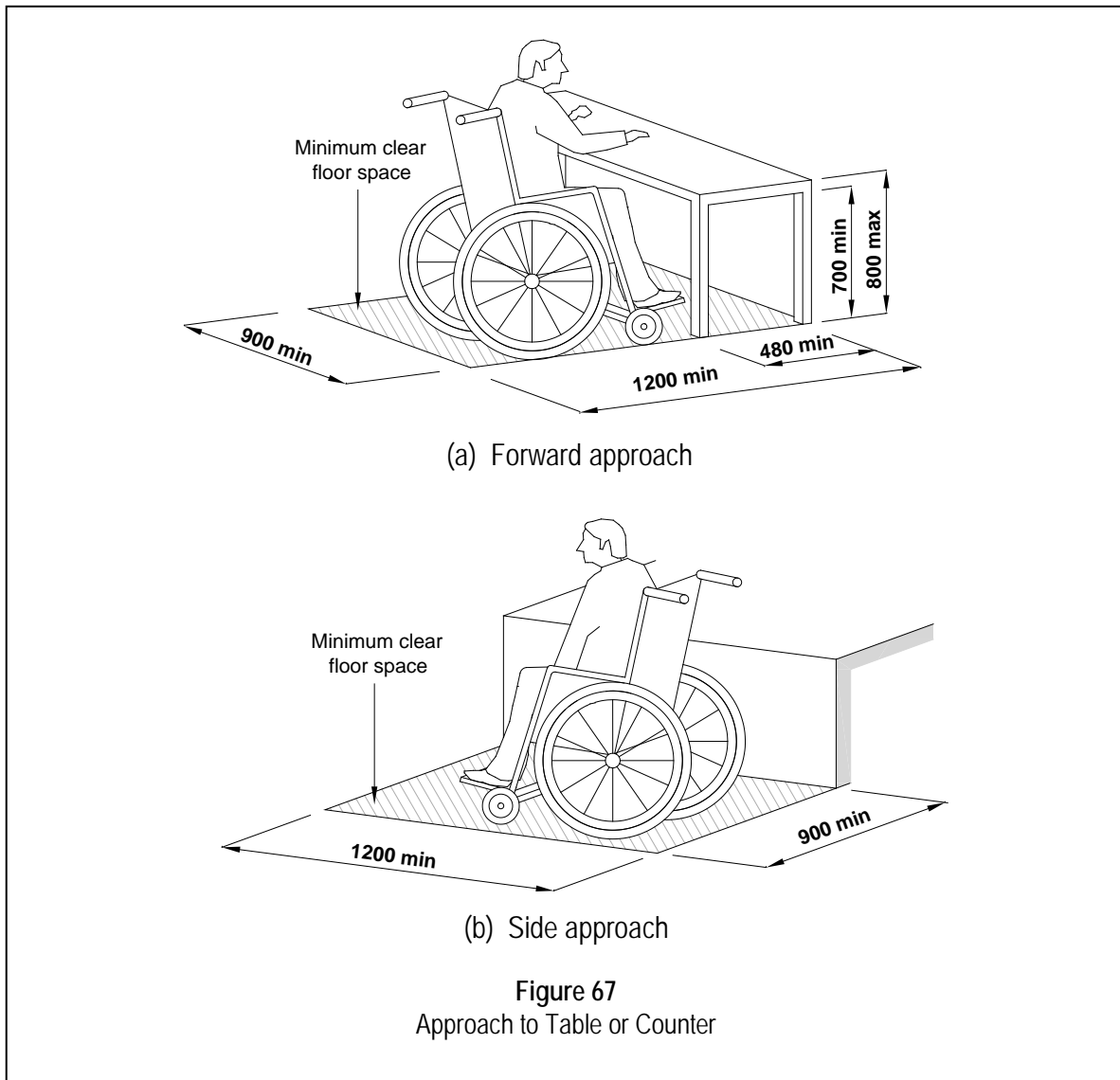

6.4 SERVICE AND INFORMATION COUNTERS

Service and information counters

6.4.1 Where service counters are provided, part of the counter shall not be more than 800 mm from the floor as shown in Figure 68 (a).

6.4.2 Where information displayed counters are provided, the bottom edge of the counter shall be at a height of between 700mm and 800mm from the floor and tilt at an angle which varies from 30° to 45° as shown in Figure 68 (c).

Note: *Where the service counters do not serve as writing surfaces, the height of the counter may be raised to not more than 860 mm.*

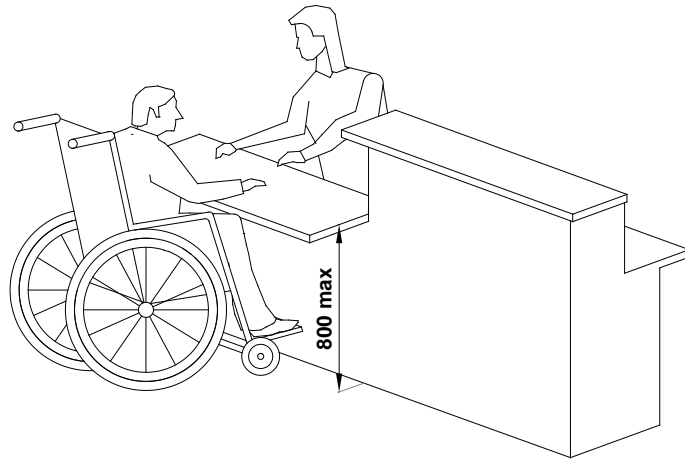

(a) Service Counters

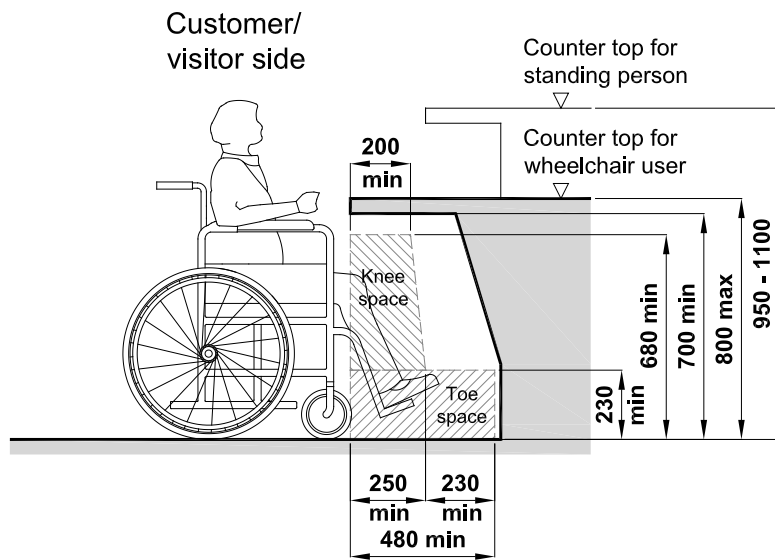

(b) Height of Service Counter

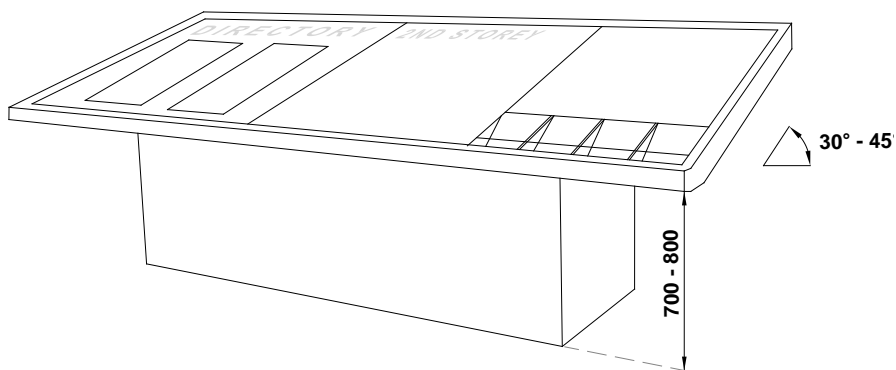

(c) Information Display Counter

Figure 68
Service and Information Counters

6.5 DRINKING FOUNTAINS

Drinking
fountains

- 6.5.1 Where drinking fountains are provided, the fountain spout should:
- (a) have an opening located between 750 mm and 800mm from the floor or ground surface as shown in Figure 69;
 - (b) be located at the front of the unit;
 - (c) direct the water flow in a trajectory that is parallel or nearly parallel to the front of the unit; and
 - (d) provide a flow of water at least 100mm high.
- 6.5.2 Controls should comply with clauses 6.2.3.1 and 6.2.3.2 and be at or near the front of the fountain.
- 6.5.3 Cantilevered drinking fountains as shown in Figure 69 should:
- (a) have a clear floor space of at least 750 mm by 1200 mm;
 - (b) have a clear knee space between the bottom of the apron and floor or ground of at least 750 mm wide, 1200 mm deep and 680 mm high; and
 - (c) have a toe space not less than 750 mm wide, 230 mm deep and 230 mm high.
- 6.5.4 Freestanding or built-in drinking fountains not having a knee space should have a clear floor space of at least 1200 mm wide by 750 mm in front of the unit as shown in Figure 69 (b).

- Note:
- (1) *A wall-mounted drinking fountain in an alcove is preferred because it does not create a hazard for persons with visual impairments. Drinking fountains that extend into corridors and have an open space underneath the fountain 680 mm in height should be protected by a wall guard.*
 - (2) *The provision of two drinking fountains at different heights is very convenient for standing adults, wheelchair users and children.*
 - (3) *The 100 mm high water flow is to allow for the insertion of a cup or a glass.*

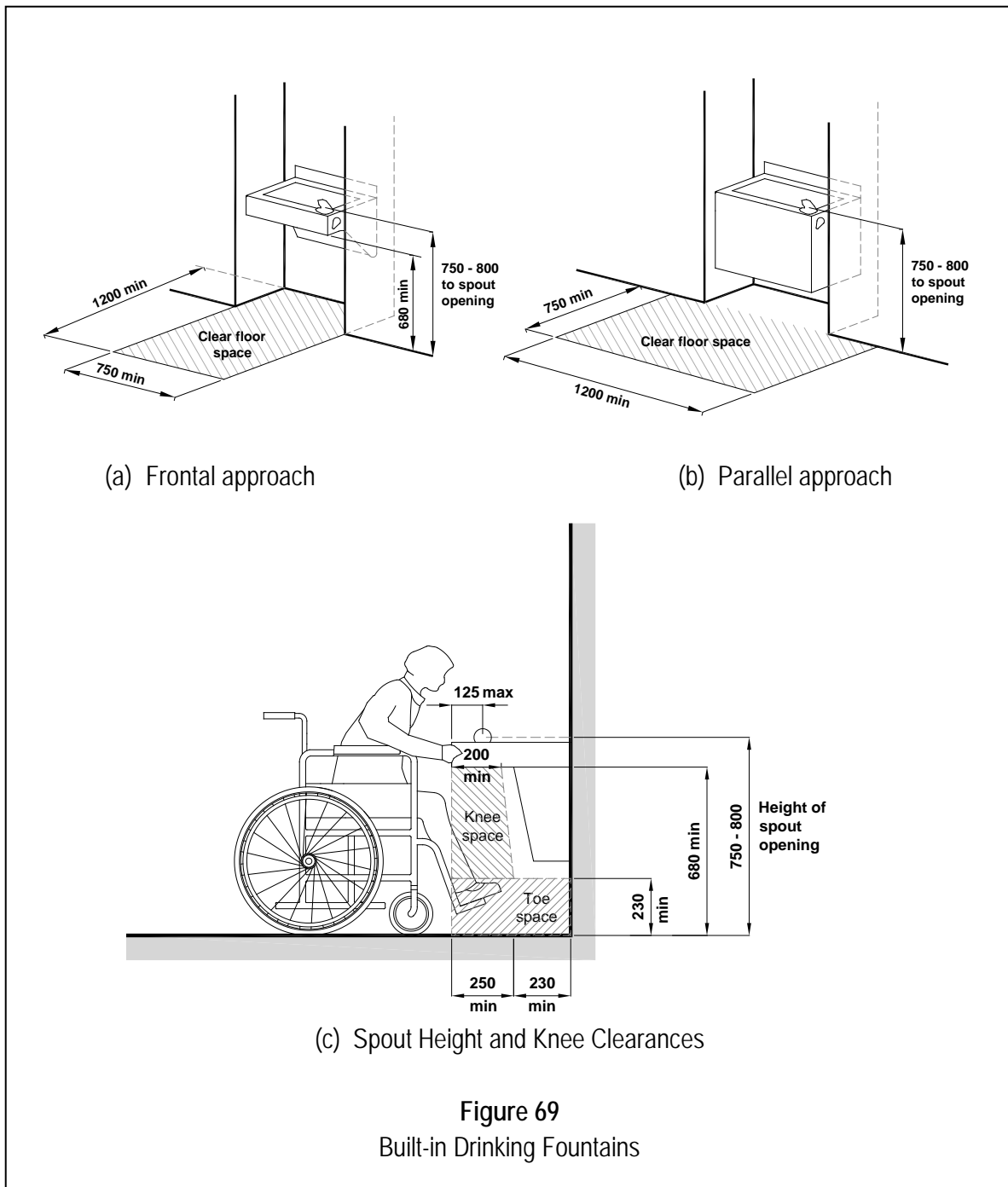

6.6 PUBLIC TELEPHONES

Public telephones

6.6.1 General

6.6.1.1 Where payphones are provided, at least one payphone shall be made accessible.

6.6.1.2 A seat adjacent to the payphone is recommended for the ambulant disabled but shall not impede the approach by a wheelchair user to the telephone.

6.6.2 Clear Floor Space

6.6.2.1 A clear floor space of 900 mm wide by 1200 mm deep or more shall be provided in front of the telephone booth or counter.

6.6.3 Counter tops

Countertops

6.6.3.1 Counter tops, where provided, shall be between 700 mm and 800 mm from the floor level and have a minimum clear knee space of 680 mm as shown in Figure 70 (a).

6.6.3.2 The depth of the counter top shall be at least 480 mm.

6.6.4 Telephone Booth

Telephone booth

6.6.4.1 The opening of the telephone booth shall have a clear width of at least 900 mm.

6.6.4.2 The enclosed space shall have dimensions of 900 mm by 1000 mm or more as shown in Figure 70 and shall not be restricted by fixed seats.

6.6.5 Height

6.6.5.1 The height of all operable parts of the telephone shall be between 800 mm and 1200 mm.

6.6.6 Telephone Cord

6.6.6.1 The minimum length of the telephone cord shall be 900 mm.

6.6.7 Telephone Books

6.6.7.1 Telephone books, if provided, shall be located within reach of a wheelchair user.

6.6.8 Signage

6.6.8.1 The symbol shall be displayed to identify the location of such telephones.

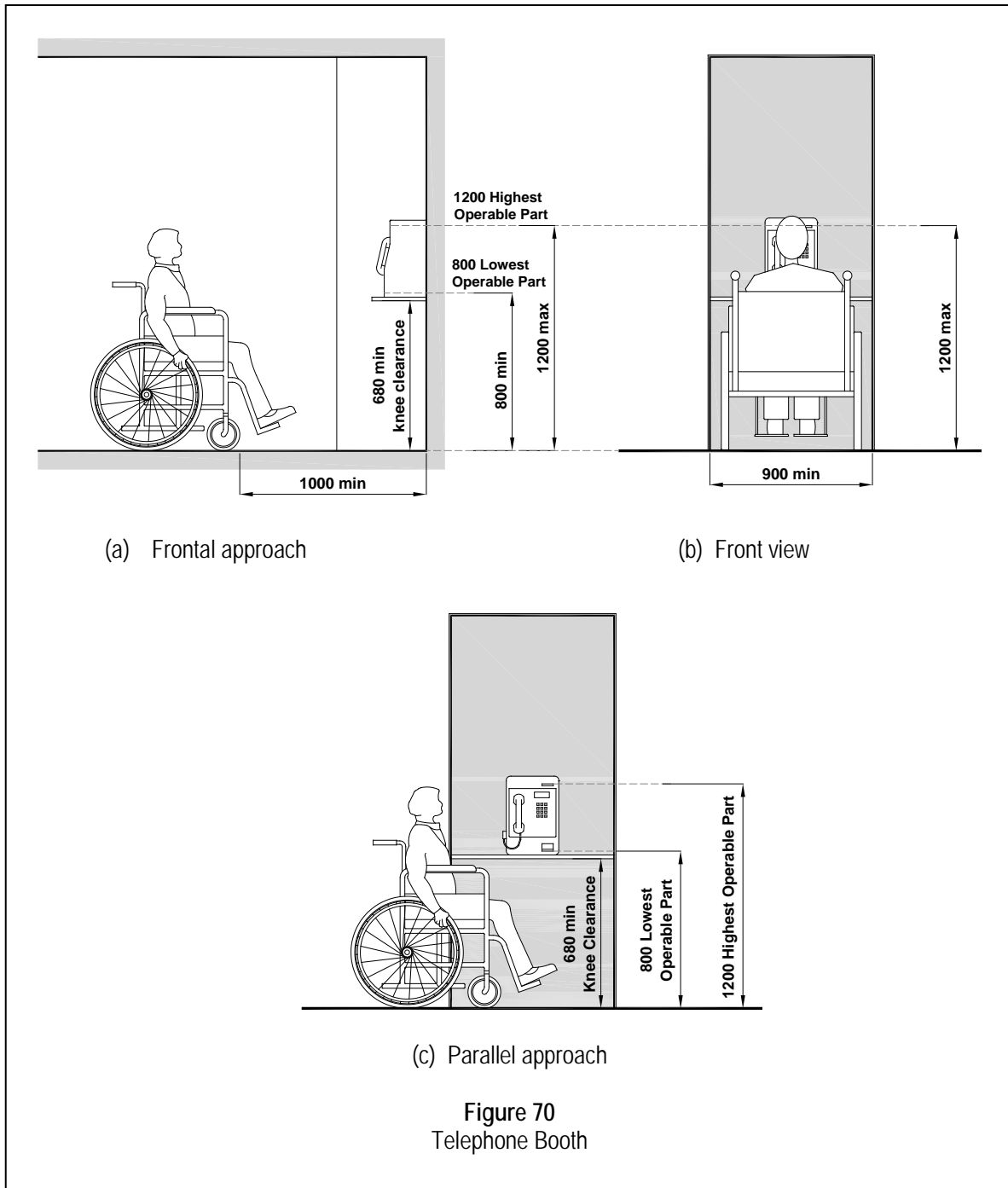

6.7 EATING SPACES

Eating outlets

6.7.1 General

6.7.1.1 Provisions of access shall be made available to persons with disabilities in accordance with clause 6.7.4 at all eating outlets and establishments, such as hawker centres, food courts or centres, fast food outlets and restaurants.

6.7.2 Signage

6.7.2.1 Directional signs shall be clearly displayed to direct persons with disabilities to the reserved table intended for their use.

6.7.2.2 Symbol of access in accordance with Chapter 8 shall be placed on the table intended for persons with disabilities as shown in Figure 71.

6.7.3 Walkways Within Outlet

6.7.3.1 A circulation path of minimum clearance 1200 mm wide shall be provided in front of the stalls.

6.7.3.2 An accessible route with a minimum clear width of 900 mm shall be provided from the circulation path to the tables intended for persons with disabilities.

6.7.4 Seating Arrangement

6.7.4.1 Where fixed seating is provided in eating outlets and establishments, at least one table for every 10 tables or part thereof shall be provided for use by persons with disabilities or at least two tables, whichever is the greater.

Fixed seats

6.7.4.2 The height of the table provided for persons with disabilities shall not be higher than 800 mm with a minimum clear knee space of 680 mm high and 480 mm deep as shown in Figure 72.

6.7.4.3 Where the eating outlet or establishment is provided with fixed seats, the minimum clear space between the seats shall be 750 mm measured along the edge of the table as shown in Figure 71.

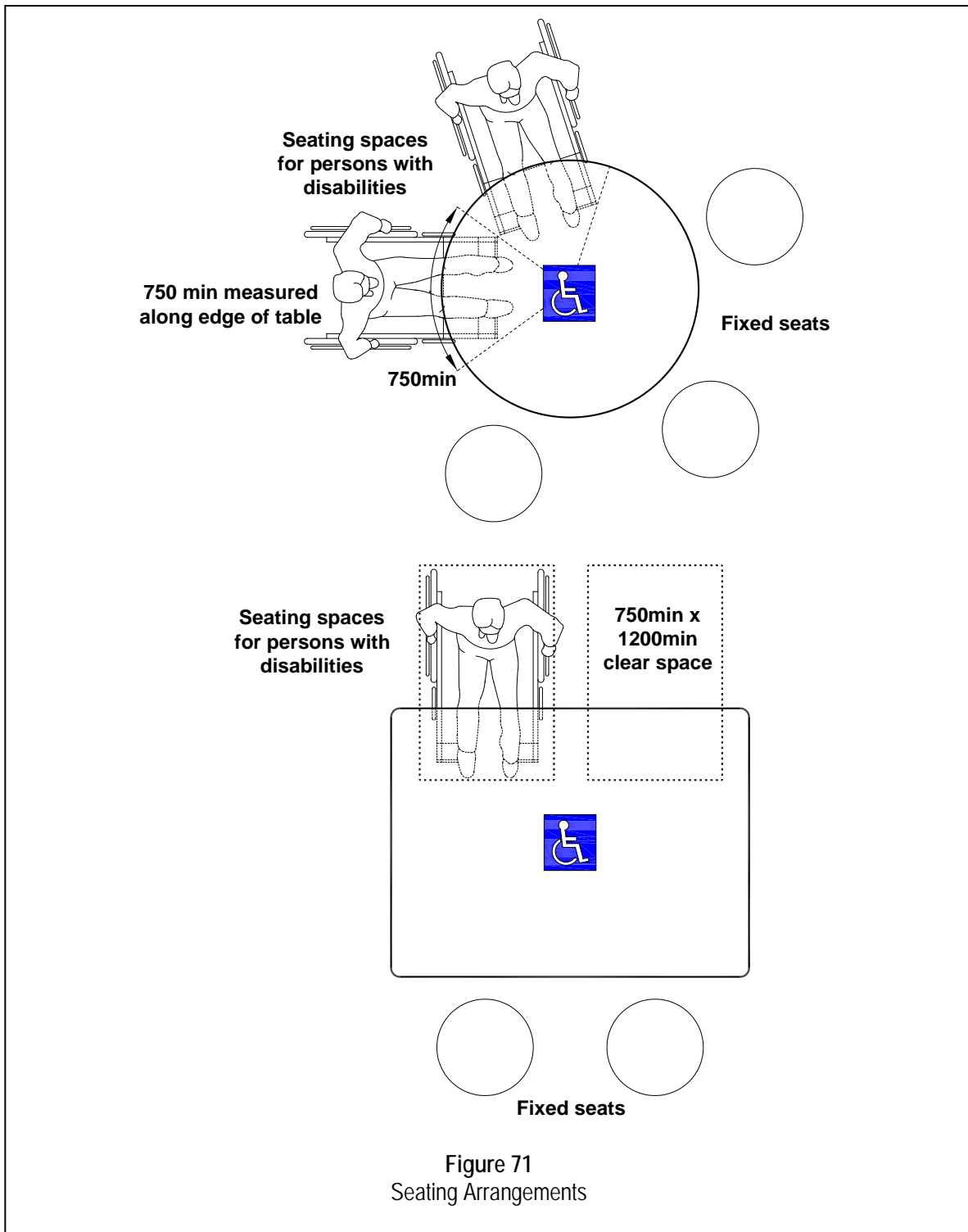

- Note:
- (1) Where fixed seats are provided, it is advisable to provide empty spaces between the seats to accommodate wheelchair users.
 - (2) It is recommended that about 40% of the total table capacity be provided with fixed seats.
 - (3) The fixed seats will cater to the ambulant disabled as well as family/friends who may accompany them.

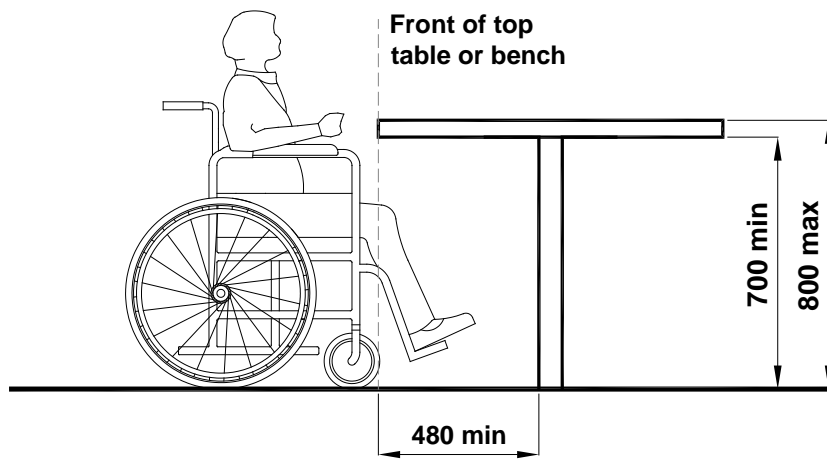

(a) Table height

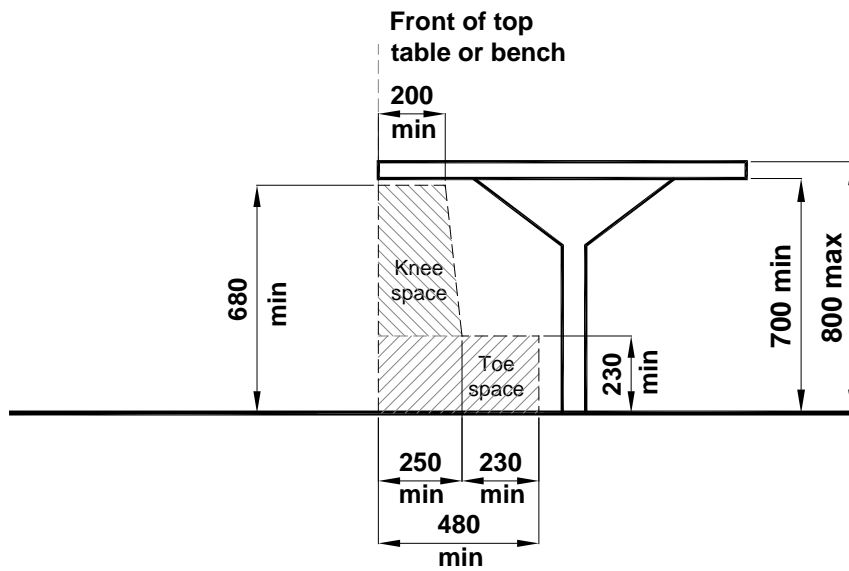

(b) Clear knee space

Figure 72
Table Dimensions

6.8 HEARING ENHANCEMENT SYSTEMS

Hearing
enhancement
systems

6.8.1 A hearing enhancement system shall be provided in:

- (a) the function rooms, halls and auditoriums used for meetings, lectures, performances or films; and
- (b) at least one of the public information/service counters for cinemas, theatres, concert halls, stadiums, shopping complexes, museums, theme parks, purpose-built family amusement centres, sport complexes, public swimming pools, hospitals, clinics, transport stations, interchanges and passenger terminal.

Note:

- (1) *A hearing enhancement system enables sound signals to be transmitted to a hearing impaired person without interference of background noise or excessive reverberation.*
- (2) *Hearing enhancement systems that operate with induction loop, infrared and radio frequency are commonly used to provide enhanced level of sound.*
- (3) *Expert advice should be sought when selecting a hearing enhancement system appropriate for the situation and purpose.*

6.8.2 Where hearing enhancement system is provided for persons with hearing impairment, the international symbol of access for hearing loss as shown in Figure 73 shall be conspicuously displayed and in accordance with clause 8.5.2.1.



Figure 73
Symbol of Access for people with Hearing Loss

6.9	FAMILY-FRIENDLY FACILITIES	Family-friendly facilities
6.9.1	General	
6.9.1.1	<p>The provision of family friendly facilities for nursing women, young children and their caregivers shall apply to the following buildings:</p> <ul style="list-style-type: none"> (a) Transport stations, interchanges and passenger terminals; (b) Sports complexes and public swimming pools; (c) Community club, theme parks and purpose-built family amusement centres; (d) Large scale shopping and multi-purpose complexes of size more than 10,000 sqm in gross floor area. 	
6.9.1.2	<p>Where a building is required to provide family-friendly facilities in compliance with clause 6.9.1.1, the following facilities shall be provided:</p> <ul style="list-style-type: none"> (a) at least one lactation room for nursing women at an appropriate location; (b) at every level where toilets are provided: <ul style="list-style-type: none"> (i) at least one diaper changing station in accordance with clause 6.9.2; (ii) at least one child protection seat in accordance with clause 6.9.3; (iii) child-friendly sanitary facilities in accordance with clause 6.9.4; (c) seating areas at appropriate locations along frequently accessed routes and spaces; and (d) at least one designated family car parking lot for motorists accompanied by a child in a baby carriage or passenger who uses mobility aids in accordance with clause 6.9.5. 	
Note	<p><i>For buildings required to provide family-friendly facilities in accordance to clause 6.9.1, the relevant requirements in Appendix A "Design Guidelines for Family-Friendly Facilities" should be adopted.</i></p>	
6.9.2	Diaper Changing Stations	Diaper changing stations
6.9.2.1	Diaper changing stations shall be located either in:	

(a) both male and female toilet clusters; or

(b) individual family washrooms.

6.9.3 Child Protection Seats

Child
protection
seats

6.9.3.1 Child protection seats shall be located either in:

(a) one of the water closet compartments in both male and female toilets clusters; or

(b) individual family washrooms.

6.9.4 Child-friendly Sanitary Facilities

Child-friendly
sanitary
facilities

6.9.4.1 Child-friendly sanitary facilities shall comply with the following requirements:

(a) consist of at least one water closet and one wash basin that are provided either in:

(i) one of the water closet compartments in both male and female toilet clusters; or

(ii) individual family washrooms; or

(iii) stand-alone children's toilet at a toilet cluster;

(b) provide at least one urinal that is suitable for young children in the male toilet or stand-alone children's toilet at a toilet cluster.

Note: *Placement of child-friendly facilities in accessible individual washrooms should be avoided so as not to unnecessarily tie-up the washroom's use for persons with disabilities.*

6.9.5 Family Car Parking Lots

Family car
parking lots

6.9.5.1 Family car parking lots shall have the minimum dimensions of 4800 mm in length by 3600 mm wide as shown in Figure 74.

Note: (1) *The number of family car parking lots provided shall be over and above the LTA's minimum parking requirements.*

(2) *The family car parking lot should be located close to entrances and lobbies for families' ease of access.*

6.9.6 Signage

6.9.6.1 Appropriate directional and service identification signs in accordance with Chapter 8 shall be displayed to identify the location of family-friendly facilities.

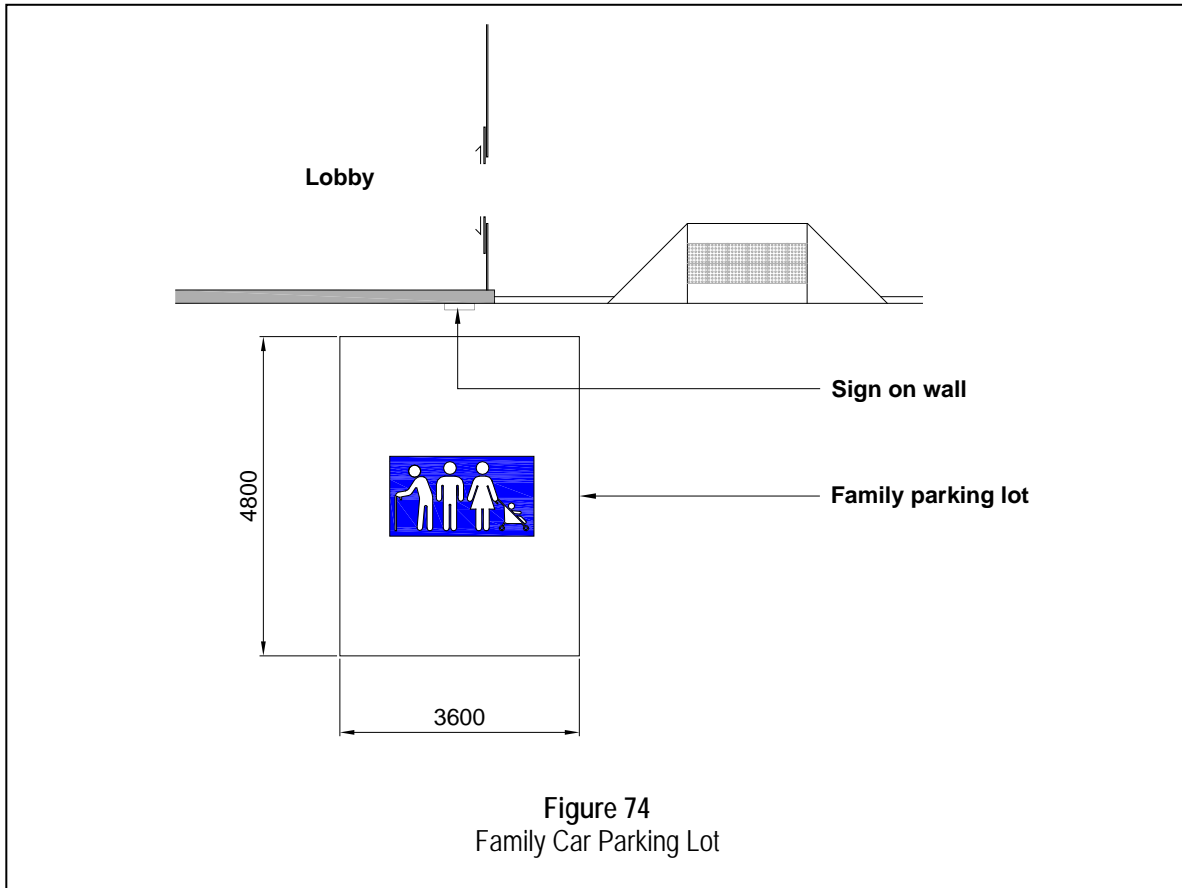

6.10 ACCESSIBLE ROOMS, GUESTROOMS AND SERVICED APARTMENTS

Accessible rooms, guestrooms and serviced apartments

6.10.1 General

6.10.1.1 The manoeuvring space at entrances to accessible rooms, guestrooms and serviced apartments provided under clause 2.3.3, 2.3.4 or 2.3.6 shall comply with the requirements of clause 7.2.1 and 7.2.2.

6.10.1.2 Doorways to entrances of accessible rooms, guestrooms and serviced apartments shall be level.

6.10.1.3 Sanitary and bath facilities serving accessible rooms, guestrooms and serviced apartments shall comply with clause 5.2 and 5.7.

Note: *Accessible rooms, guestrooms or serviced apartments should be designed to provide a choice of locations and have standard facilities equivalent to that of other rooms or units.*

6.10.2 Clear Floor Space

6.10.2.1 An unobstructed clear floor space of 1500 mm by 1500 mm or more as shown in Figure 75 shall be provided for wheelchairs to manoeuvre within the room.

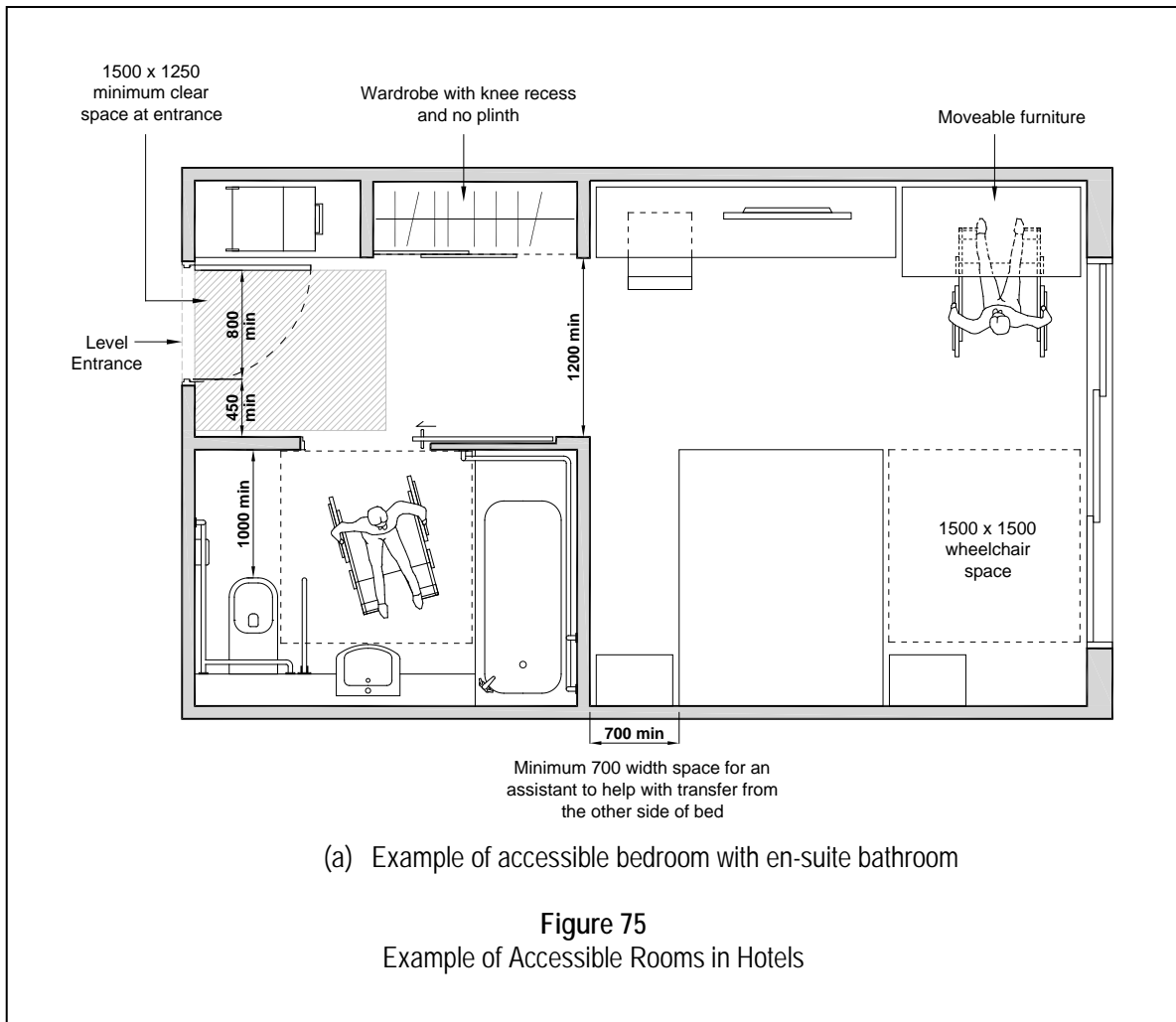

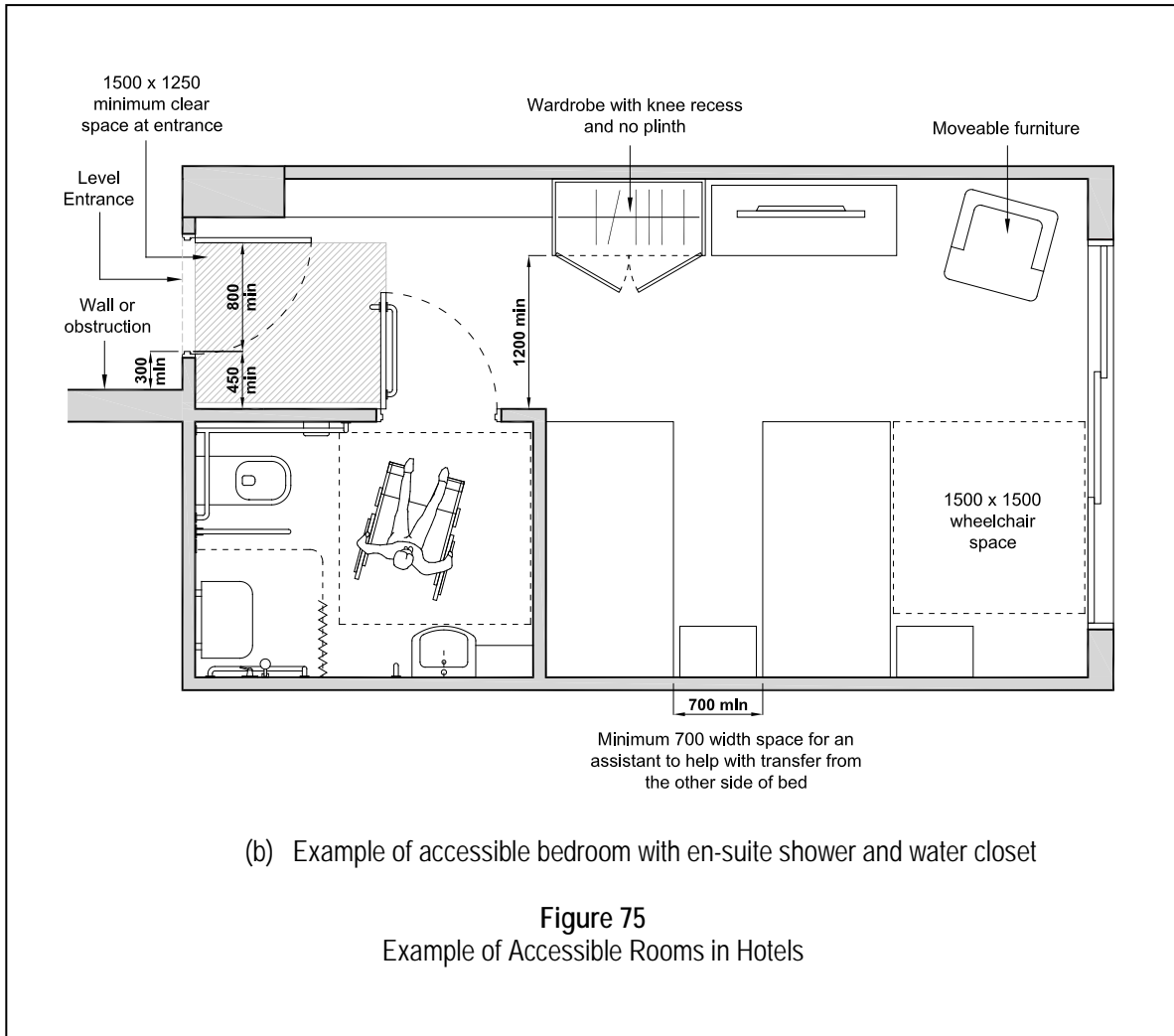

CHAPTER 7

RESIDENTIAL DEVELOPMENTS

Objective : Accessibility for residential developments.

All common areas of the residential developments shall be accessible for person with disabilities. Residential units shall be designed so that they can be easily retrofitted without the necessity for substantial alterations to support aging-in-place.

- | | | |
|---|--|---------------|
| ▪ | General Requirements | CI 7.1 |
| ▪ | Entrances to Units | CI 7.2 |
| ▪ | Bathrooms for future retrofitting | CI 7.3 |
| ▪ | Switches and Socket Outlets | CI 7.4 |

- | | | |
|------------|---|--------------------|
| 7.1 | GENERAL REQUIREMENTS | Requirements |
| 7.1.1 | There shall be at least one accessible and sheltered passenger alighting and boarding point with direct access to every block of the residential development. | |
| 7.1.2 | The minimum width for accessible routes shall be in accordance to clause 4.2.1. | |
| 7.1.3 | Where toilets for common facilities are provided, they shall comply with clause 5.1. | |
| 7.2 | ENTRANCES TO UNITS | Entrances to units |
| 7.2.1 | The doorway of the entrance shall be 800 mm minimum for a single leaf door. If the doorway has two independently operated door leaves, at least one active leaf shall be 800 mm minimum. The clear width of the entrance for single-leaf and double-leaf doorway is shown in Figure 76. | |
| 7.2.2 | The manoeuvring space at the entrance shall: | |
| | (a) within the unit, have a minimum space of 450 mm adjacent to the leading edge of the door with minimum clear floor space of 1250 mm wide by 1500 mm deep as shown in Figure 76 and Figure 77; and | |
| | (b) on the push side, have a minimum space of 300 mm adjacent to the leading edge of the door as shown in Figure 76. | |

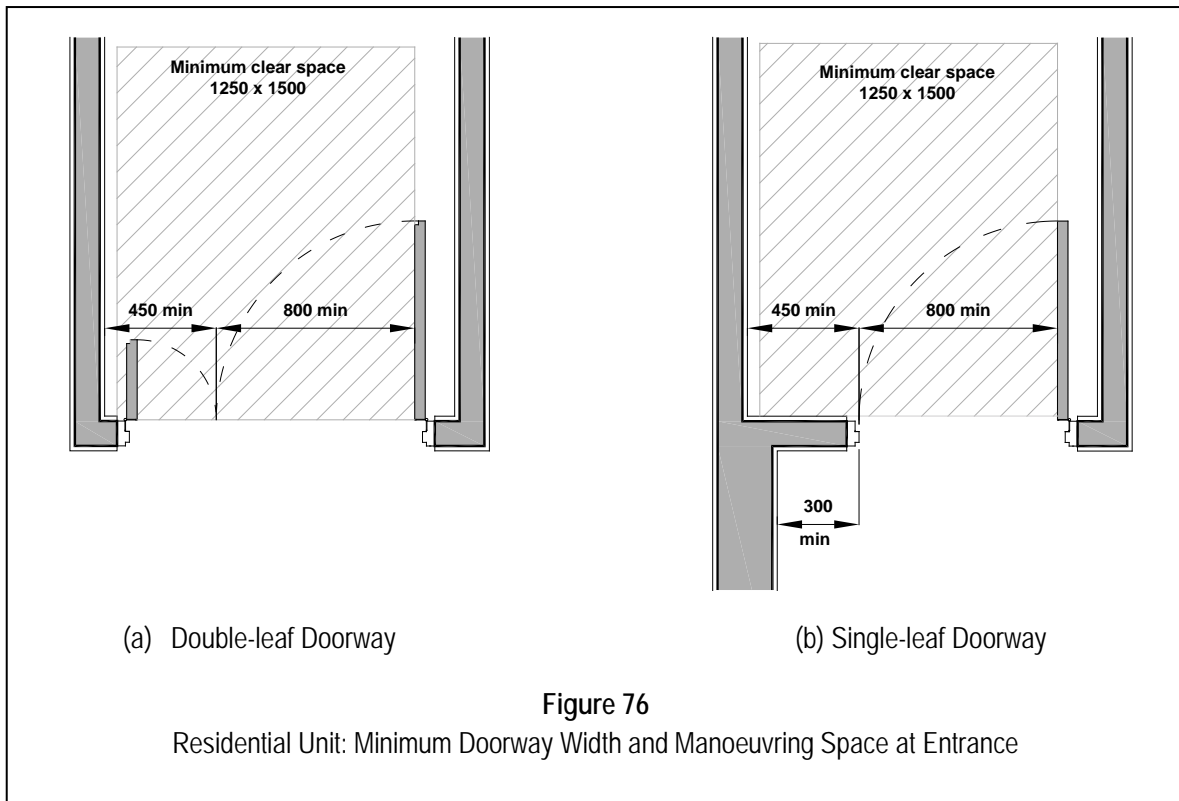

- 7.2.3 Doorways should be level. However, if required for functional reasons, the differences in levels between the floor of the entrance to the residential unit and the abutting common area shall not be more than 50 mm.
- 7.2.4 In addition to clause 7.2.3, where there is a level difference of more than 25 mm between the floor of the entrance to the residential unit and the abutting common area as shown in Figure 78 (a), the adjacent space fronting the entrance shall be of non-structural elements that can be easily removed for ramp installation when required.
- 7.2.5 Where a ramp is installed at the entrance to the unit as shown in Figure 78 (b) to mitigate differences in levels, the ramp shall be located within a distance of 250 mm measured from the face of the door and have a gradient in accordance with Table 4.

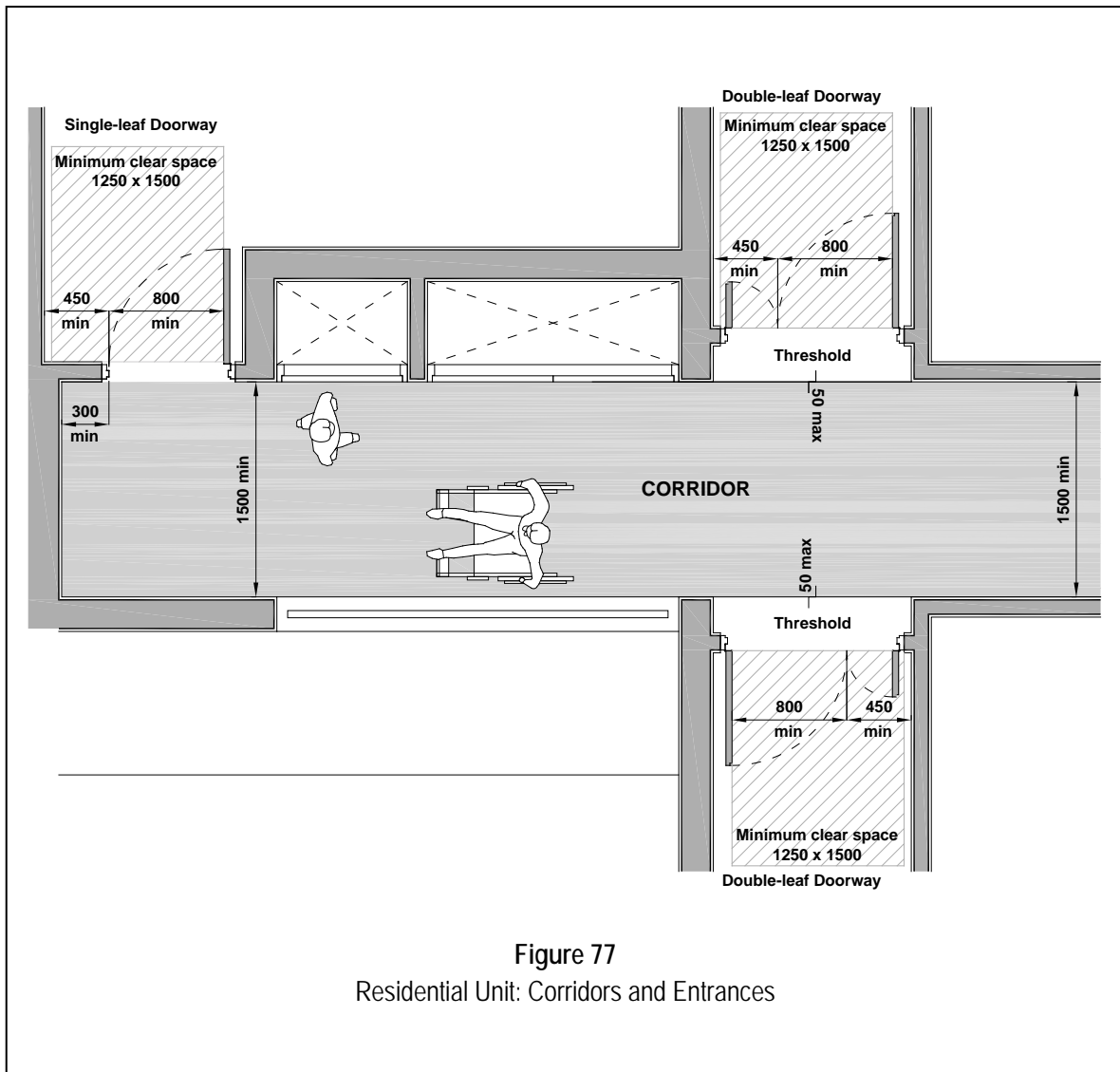
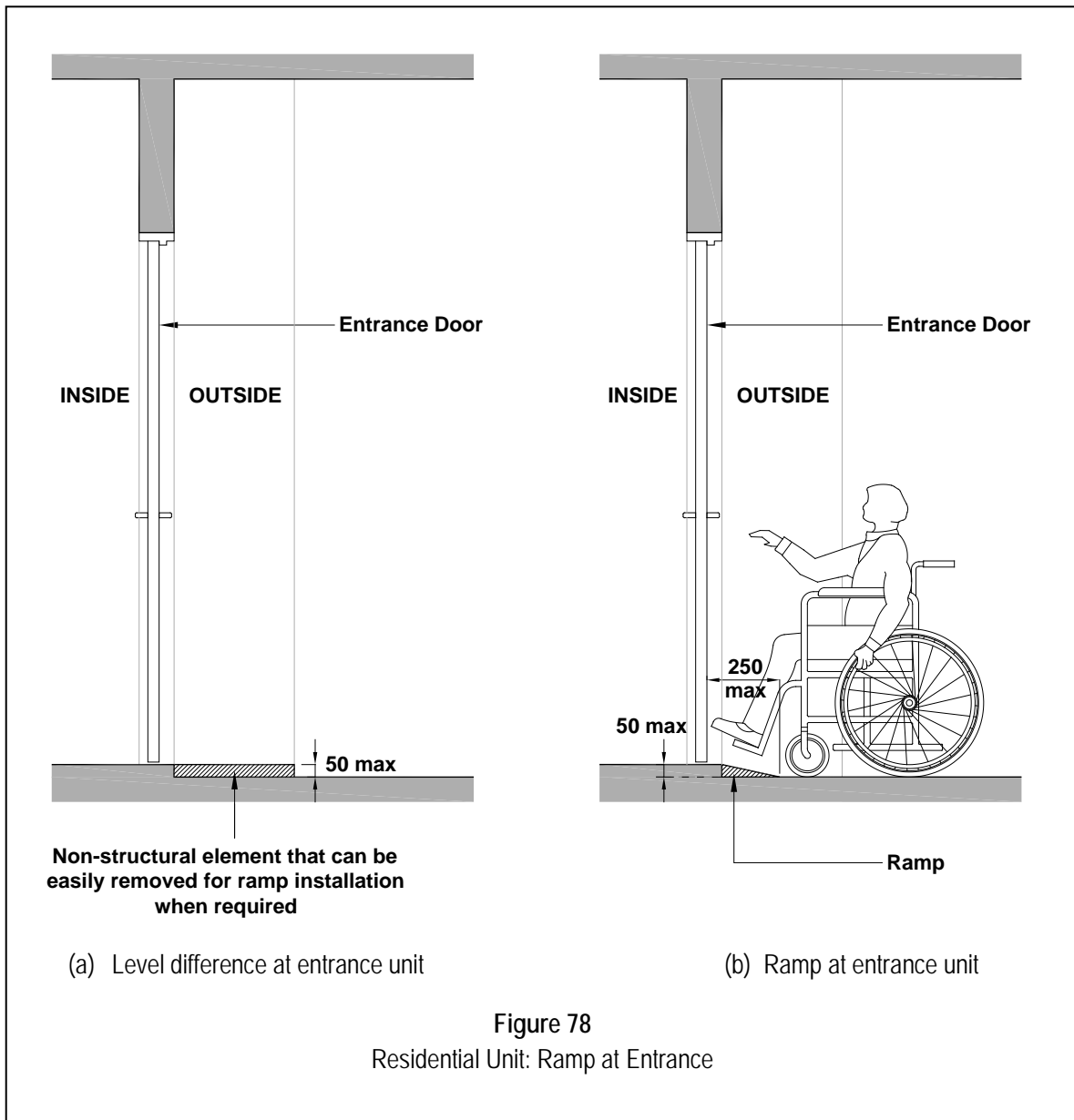

Figure 77
Residential Unit: Corridors and Entrances



7.3 BATHROOMS FOR FUTURE RETROFITTING

- 7.3.1 There shall be at least one bathroom with water closet, wash basin and shower facility in every residential unit that can be easily retrofitted for older persons and wheelchair users.
- 7.3.2 The bathroom shall be located at the same level as the entrance of the unit.
- 7.3.3 The width of the access route leading to the bathroom, or the room where the bathroom is, shall be 1000 mm minimum, subject to the provisions in Table 6.

Bathrooms for future retrofitting

7.3.4 The doorway of the bathroom and the clear space in front of the doorway shall comply with the dimensions in Table 6; and a typical layout illustrating the width of the doorway at a right angle to an access route is shown in Figure 79 (a) and (b).

Note: *If swing door is used, adequate space should be provided to ensure there is no obstruction to the user while opening and closing the door.*

TABLE 6
Minimum Clear Width of Door Openings for Residential Units

Width of the doorway	Minimum corridor width perpendicular to the doorway
900 mm	1000 mm
850 mm	1100 mm
800 mm	1200 mm

7.3.5 The bathroom shall have:

- (a) an unobstructed passageway with a minimum width of 1000 mm leading from the doorway to the water closet and wash basin as shown in Figure 79; and
- (b) a clear floor space of at least 1000 mm by 1000 mm at the front edge of the water closet.

7.3.6 There shall preferably be no change in level of the floor surface at the doorway of the bathroom. If there is a change in level, it shall not be more than 25 mm.

7.3.7 Provisions shall be made in the bathroom walls so as to allow the installation and safe use of grab bars complying with clause 4.7.2.

7.3.8 If the bathroom for future retrofitting is accessed through another room as shown in Figure 79 (b), the clear opening of the doorway of the room shall be in accordance with clause 7.3.3 and 7.3.4.

Bathroom sited in another room

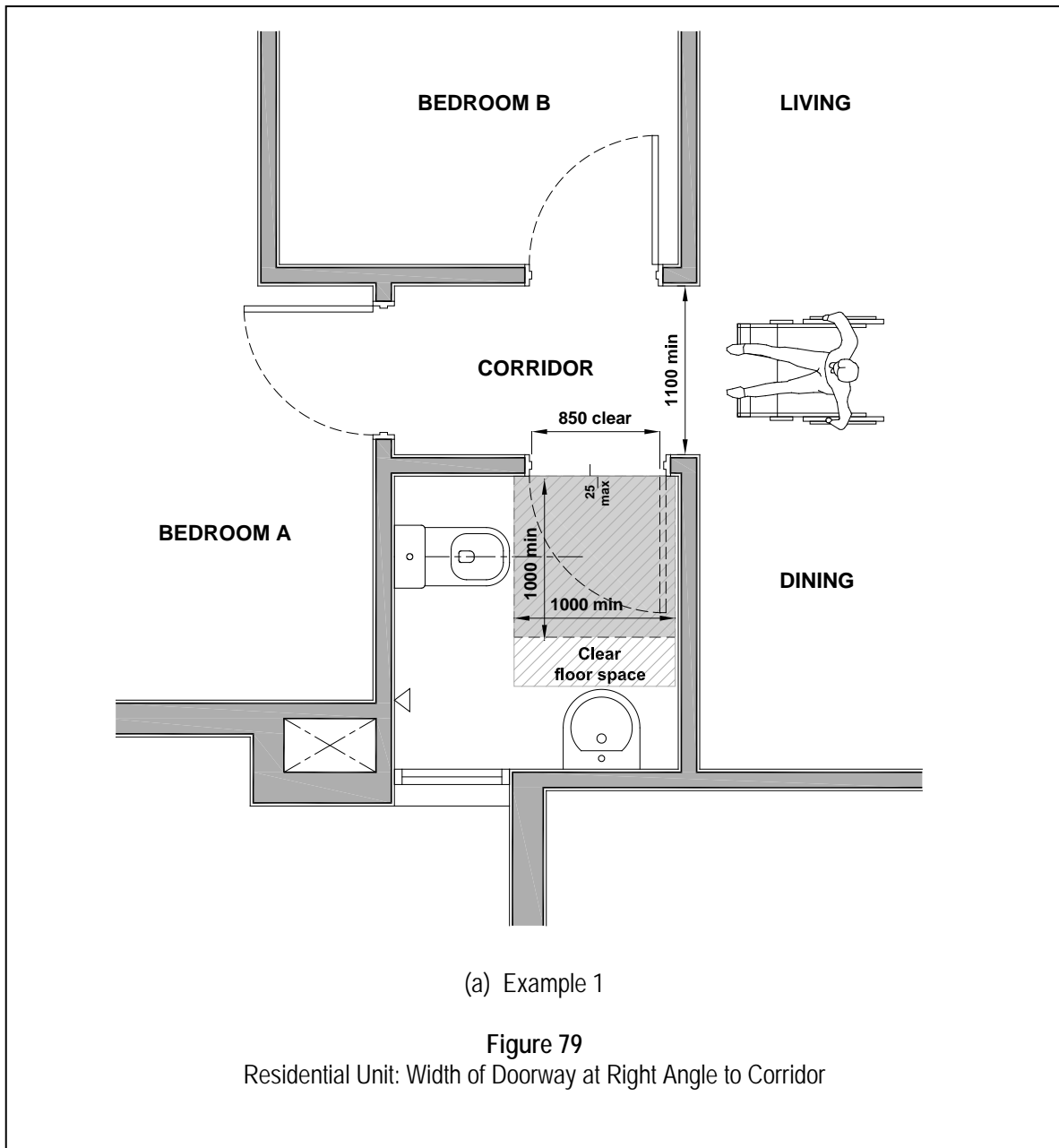

(a) Example 1

Figure 79

Residential Unit: Width of Doorway at Right Angle to Corridor

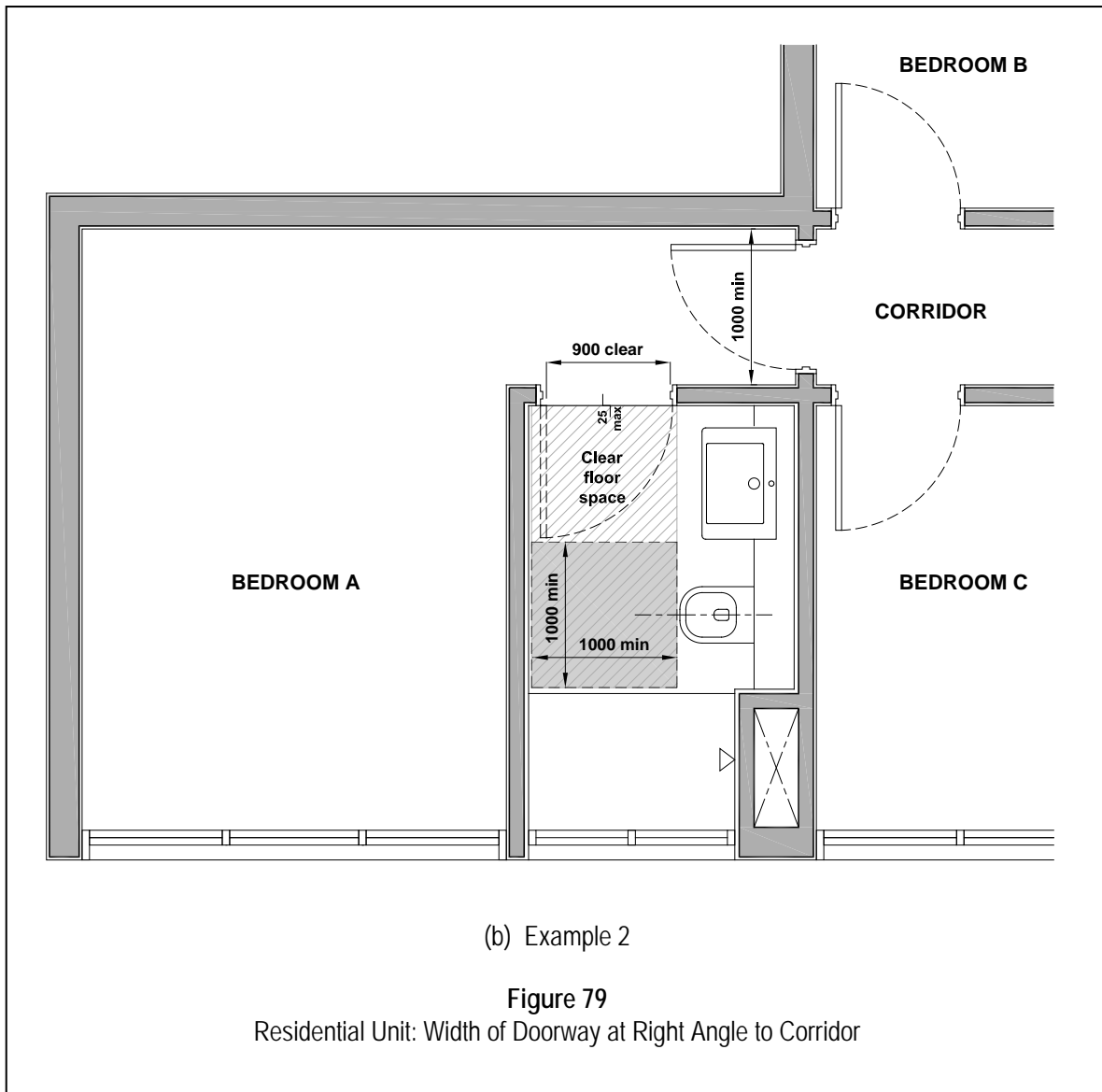

7.4 SWITCHES AND SOCKET OUTLETS

Switches and socket outlets

7.4.1 The switches and socket outlets shall be provided at a height of between 450 mm and 1200 mm from the floor level as shown in Figure 64 (b).

- Note:
- (1) Height of switches and socket outlets in residential units' kitchen are not required to comply with clause 7.4.1.
 - (2) All measurements shall be to the centre line of the switches and socket outlets.

CHAPTER 8

ANTHROPOMETRICS AND SIGNAGE

Objective : Space Allowances and Signage

Facilities and equipment shall have adequate space allowances for safe and easy use by persons with disabilities. Signage shall be provided to give clear directions and information on the facilities in a building.

- Anthropometrics and Space Allowances CI 8.1
- International Symbol of Access for Persons with Disabilities CI 8.2
- Directional Signs CI 8.3
- Service Identification Signs CI 8.4
- Signage CI 8.5

8.1 ANTHROPOMETRICS AND SPACE ALLOWANCES

8.1.1 Clear Floor Space

Clear floor space

8.1.1.1 The minimum clear floor space required to accommodate a single, stationary wheelchair and occupant shall be 900 mm by 1200 mm as illustrated in Figure 80 (a) and (b).

8.1.1.2 A minimum clear floor space of 1200 mm by 1200 mm, as illustrated in Figure 80 (c), would allow access for both forward and parallel approaches.

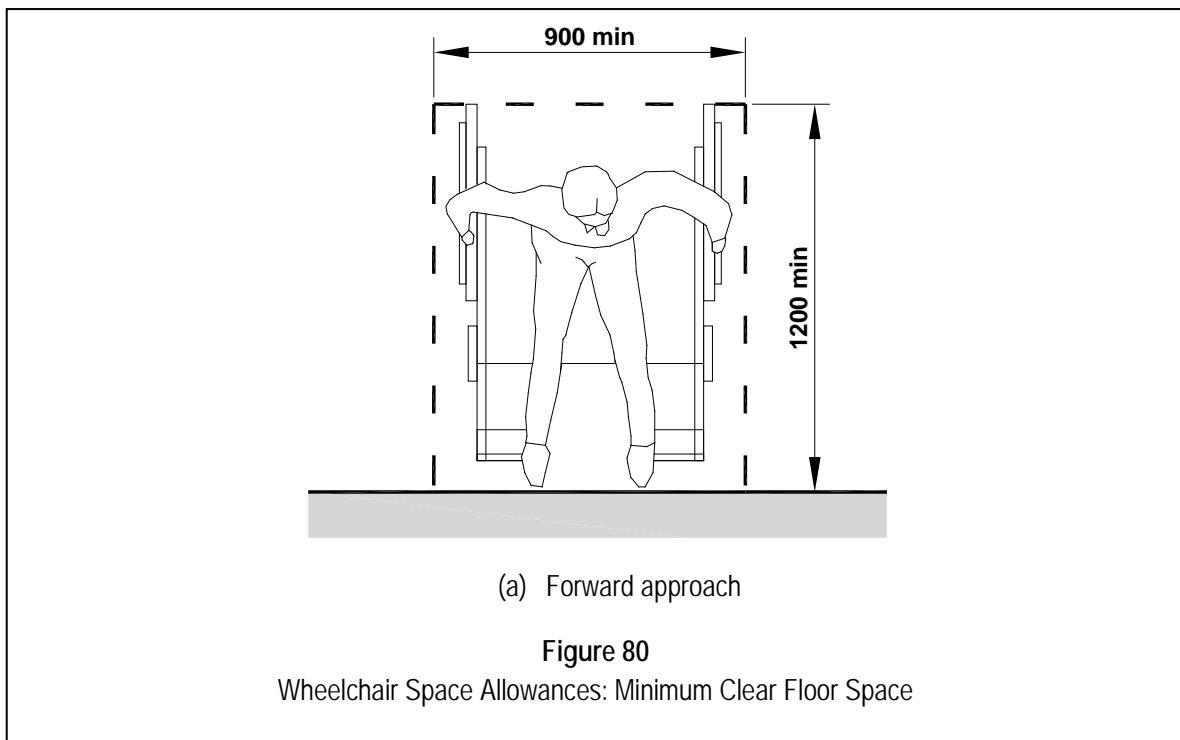

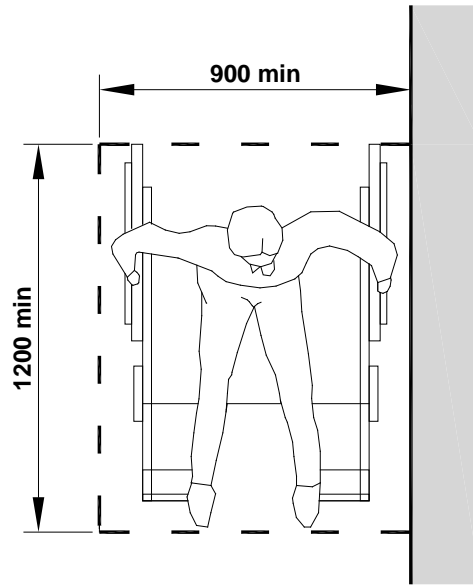

(b) Parallel approach

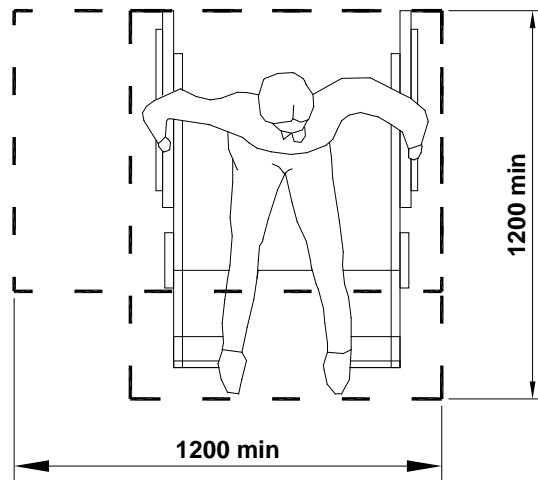

(c) Clear floor space

Figure 80

Wheelchair Space Allowances: Minimum Clear Floor Space

- 8.1.1.3 The minimum clear floor space for a wheelchair to turn shall be 1800 mm by 1800 mm as illustrated in Figure 81.

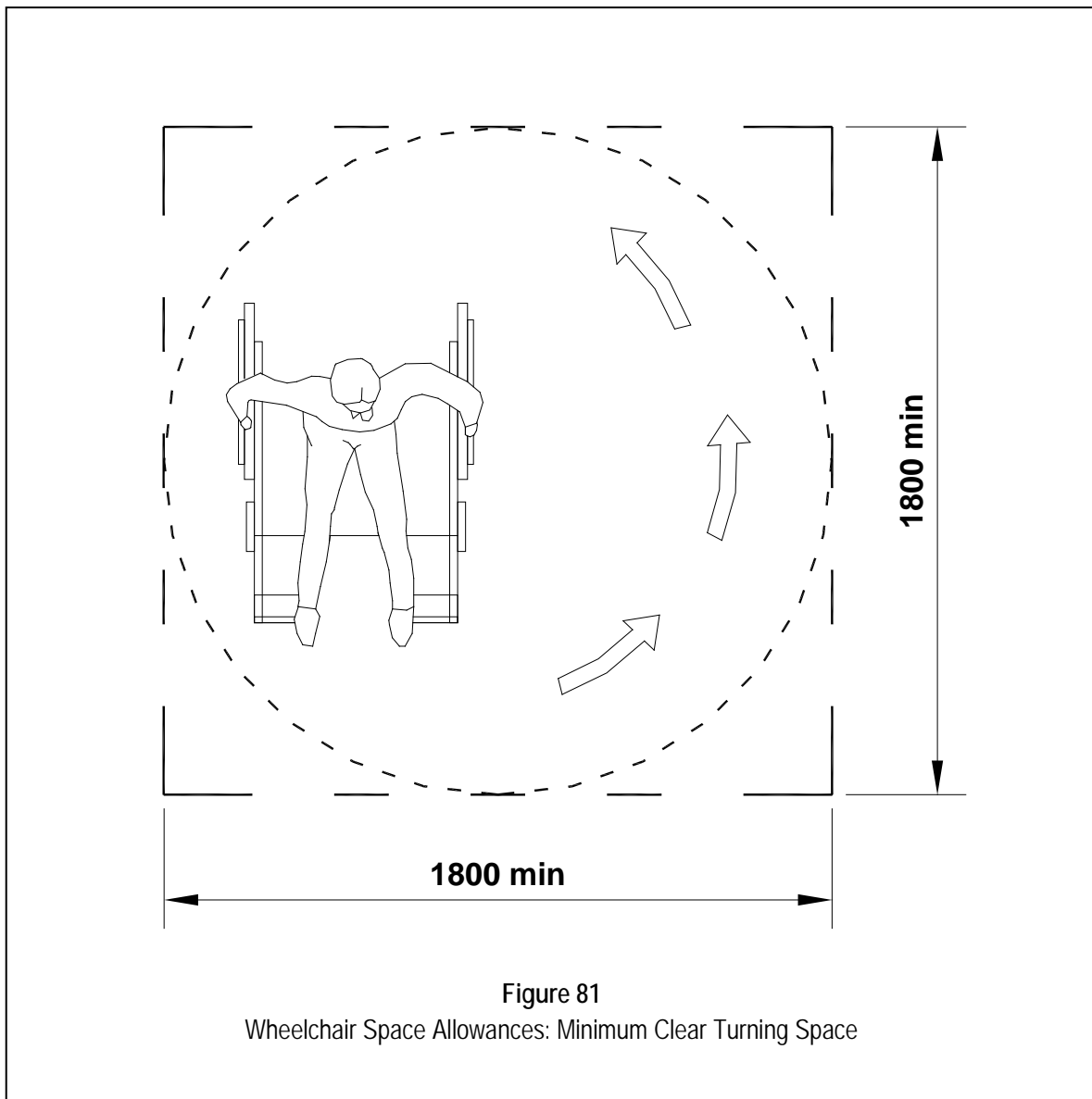

8.1.2 Wheelchair Dimensions

Wheelchair dimensions

- 8.1.2.1 Figure 82 describes some of the typical dimensions of a standard wheelchair. Other types of wheelchairs such as motorised wheelchairs may have different dimensions, weight and manoeuvrability. In determining the circulation space requirements of wheelchair users, the overall dimensions of the type of wheelchair used and the ability of the occupant to manoeuvre the wheelchair should be taken into consideration.

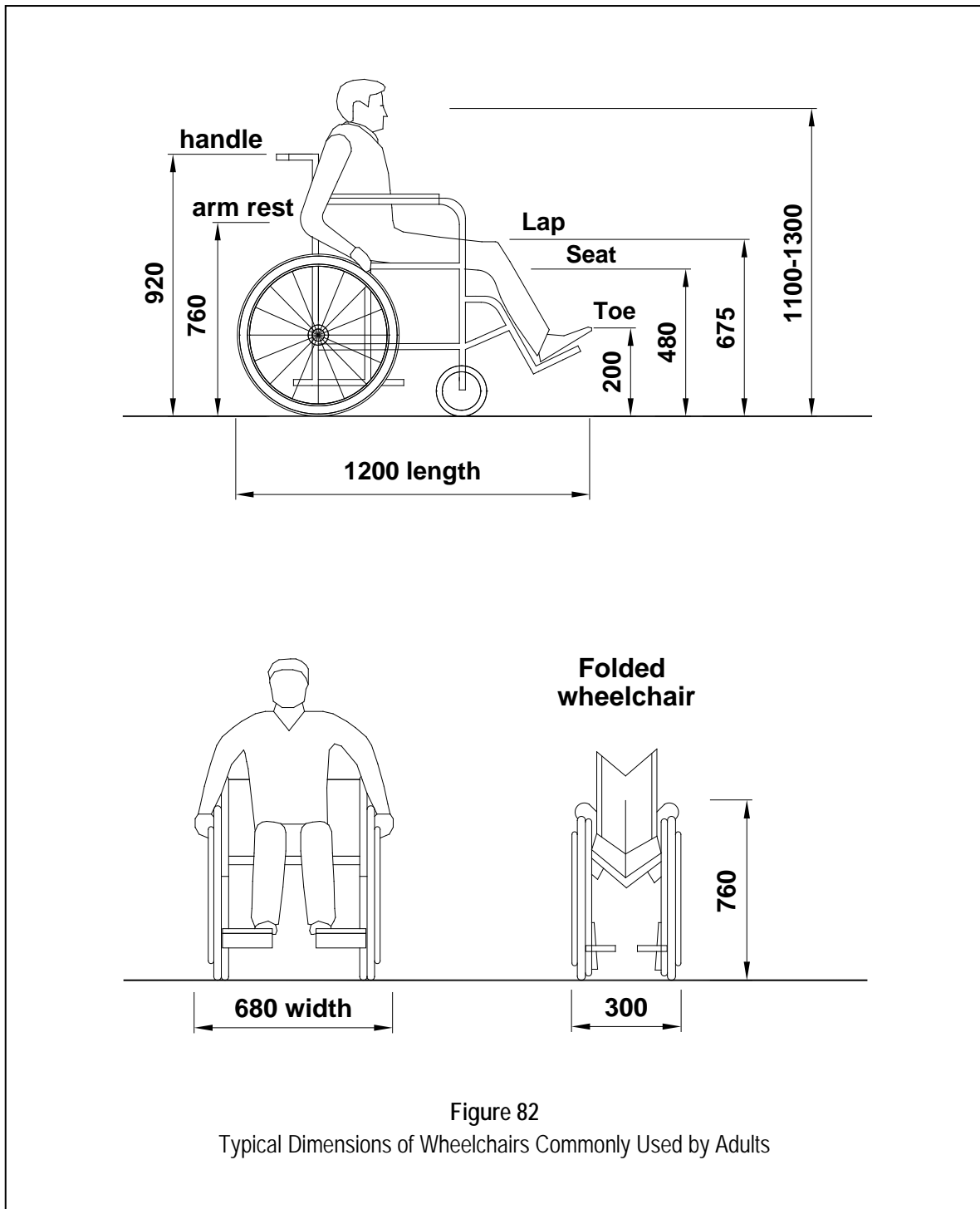

8.1.3 Reach ranges for a person in a wheelchair

8.1.3.1 Forward reach

Forward reach

8.1.3.1.1 The maximum forward reach, without obstruction, is 1200 mm from the floor and the minimum forward reach is 400 mm from the floor as shown in Figure 83.

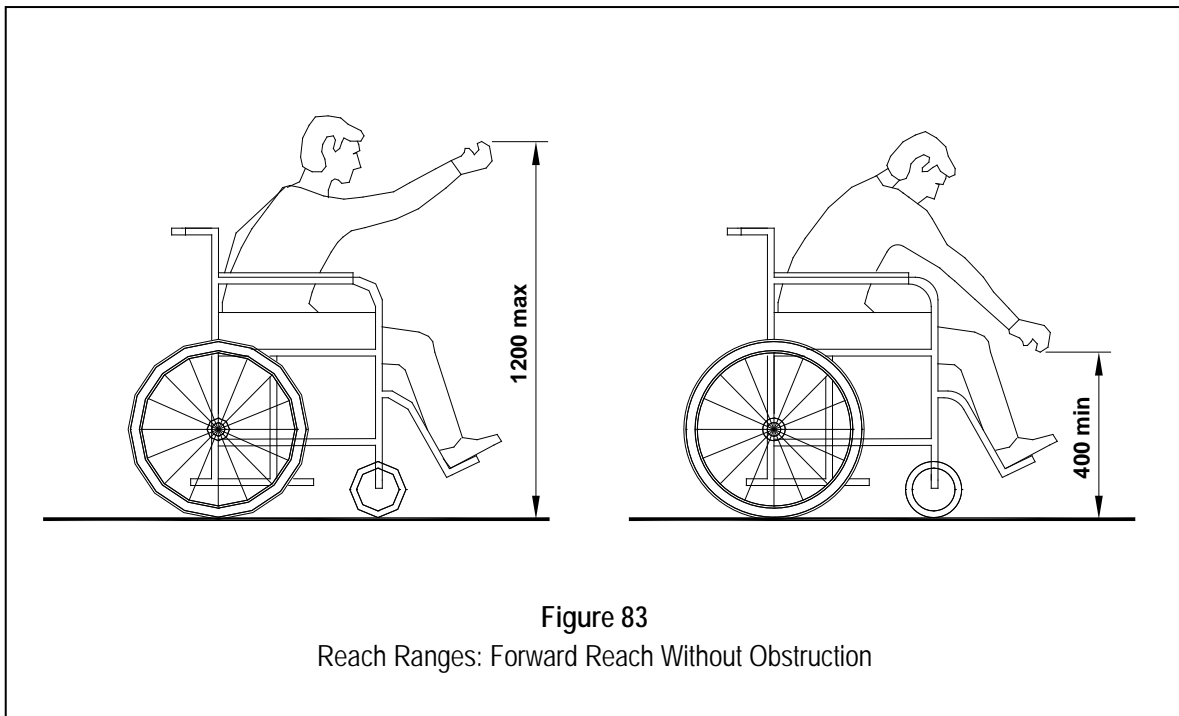

8.1.3.1.2 The maximum forward reach over an obstruction 500 mm deep is 1100 mm from the floor as shown in Figure 84.

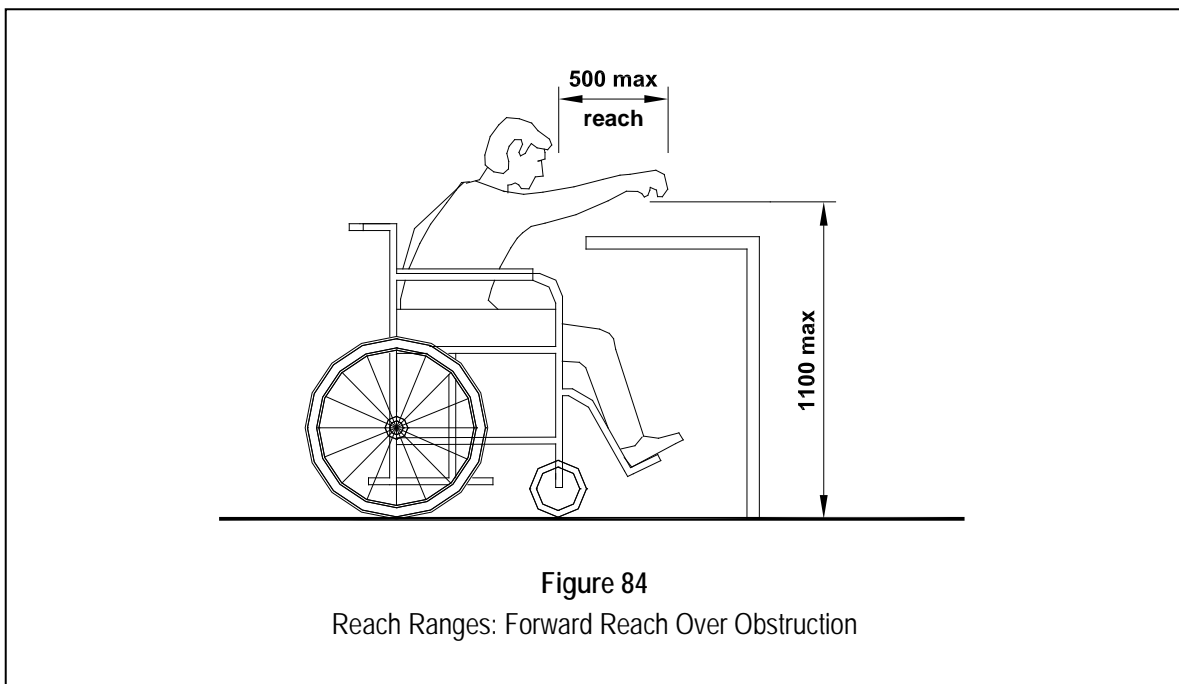

8.1.3.2 **Side reach**

Side reach

8.1.3.2.1 The maximum side reach, without obstruction, is 1300 mm from the floor and the minimum side reach is 250 mm from the floor as shown in Figure 85.

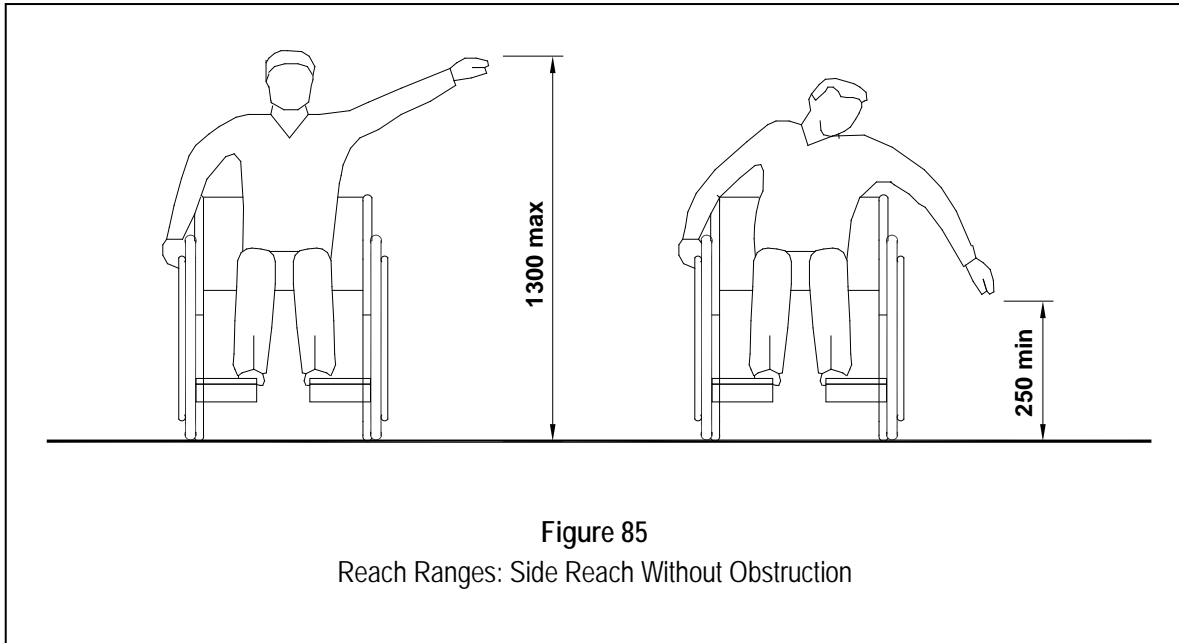

8.1.3.2.2 The maximum side reach over an obstruction 860 mm high by 500 mm deep is 1200 mm from the floor as shown in Figure 86.

Note: *When designing for a specific individual, the actual reach limitations should be taken into account.*

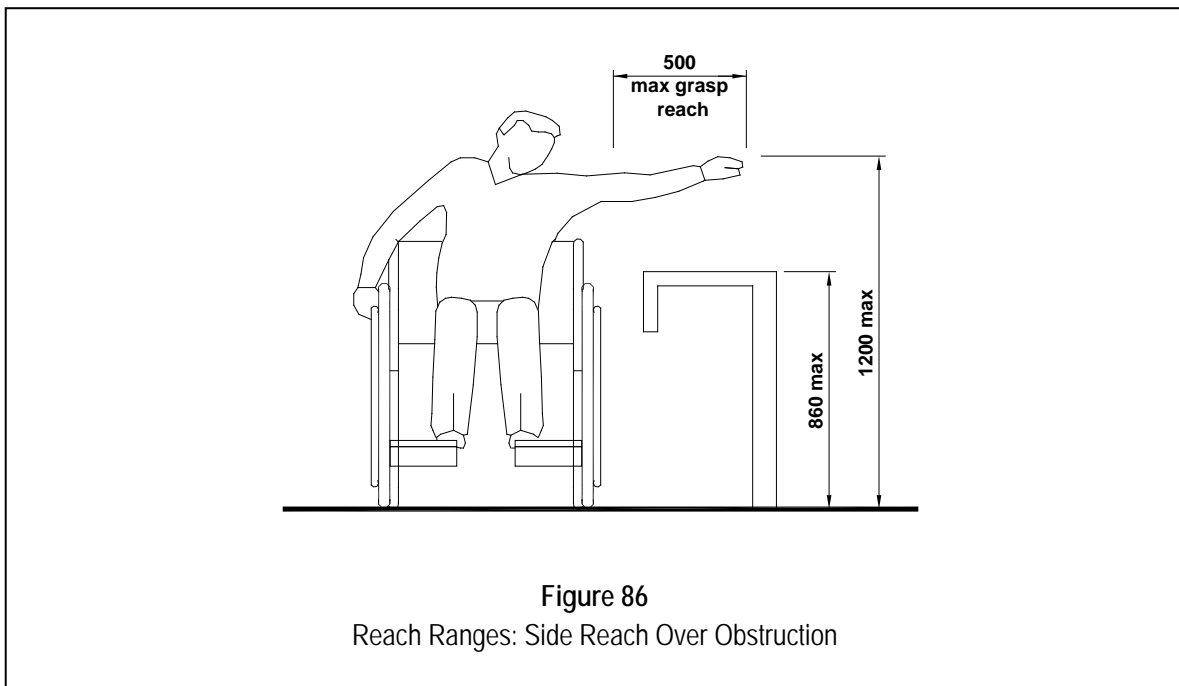

8.1.4 Negotiating a Door in a Passageway

8.1.4.1 The position taken by a wheelchair user when negotiating a door in a passageway is illustrated in Figure 87.

Negotiating door in a passageway

8.1.4.2 From position 1, the wheelchair must move to position 2 so that the user can reach the door latch and swing the door open. Since a lateral shift of the rear drive wheels of a wheelchair cannot be achieved in straight travel other than by turning, the chair must follow the track 1 to 2 to 3.

8.1.4.3 After swinging the door open, the chair needs to be backed and turned in to the open doorway and then following the path of travel to position 3.

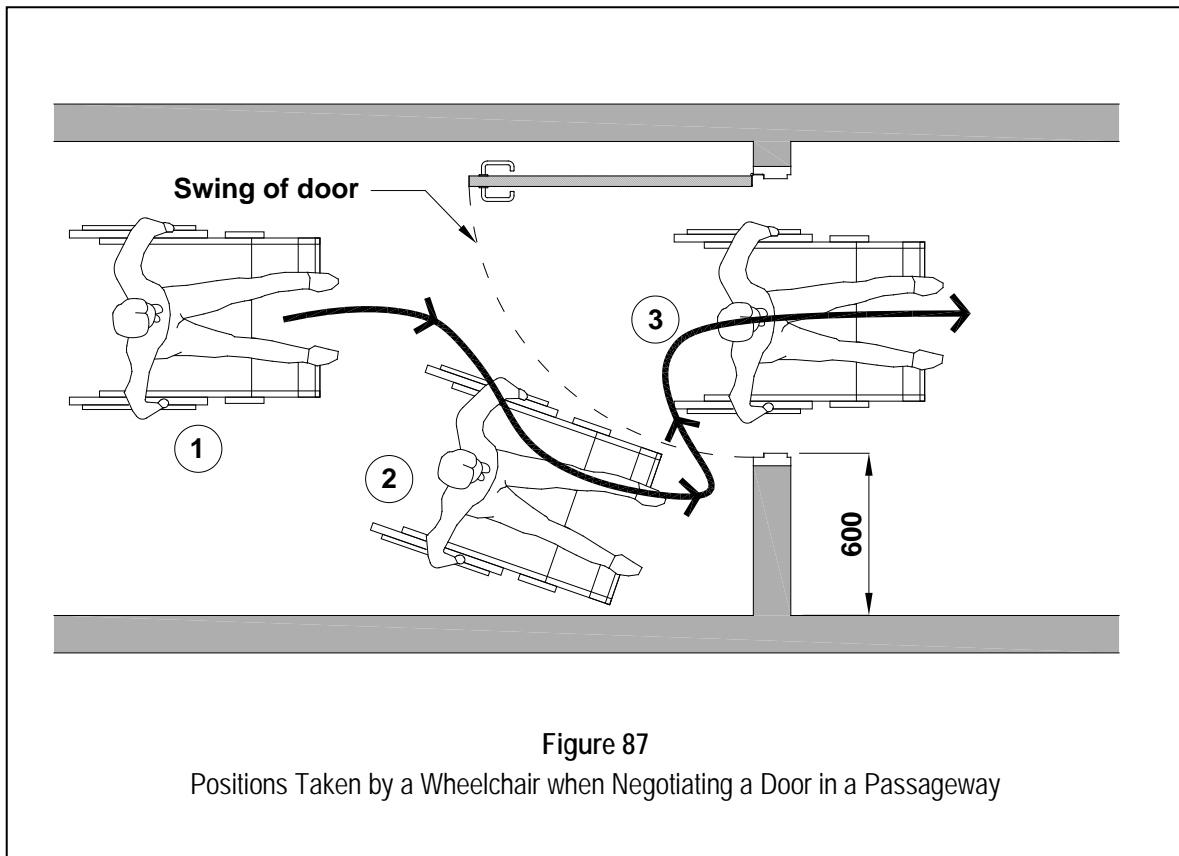

8.1.5 Walkway Widths

Walkway widths

8.1.5.1 Adequate space allowances should be provided for different users passing on an access route as shown in Figure 88. Although people who use walking aids can manoeuvre through minimum door openings of 850 mm clear width, they need wider passageways or walkways for comfortable gaits. Crutch tips, often extending down at a wide angle, are a hazard in narrow passageways where they might not be seen by other pedestrians.

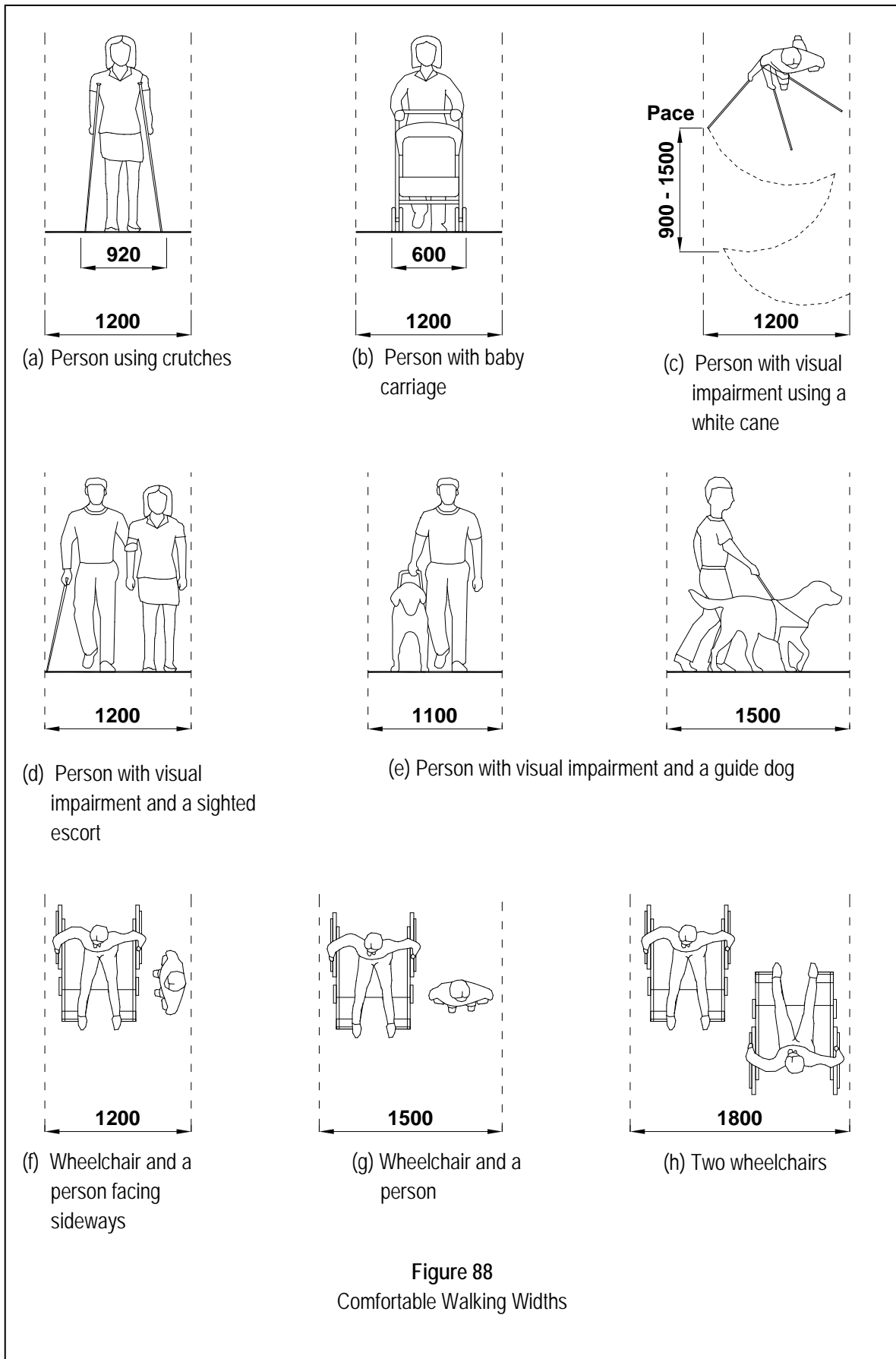

- 8.2 INTERNATIONAL SYMBOL OF ACCESS FOR PERSONS WITH DISABILITIES** Signs
- 8.2.1 General**
- 8.2.1.1 Where a building is required to be made accessible in compliance with clause 2.1 of Chapter 2, the attention of all users shall be drawn to the facilities available in order that persons with disabilities are made aware of the existence of suitable provisions for them.
- 8.2.1.2 The International Symbol of Access shall be permanently and conspicuously displayed to direct or indicate the location of the various facilities in the building.
- 8.2.1.3 Persons with disabilities may have limitations in the movement of their heads or a reduction in peripheral vision. Signs that are positioned perpendicular to the path of travel are the easiest for them to notice. Persons can generally distinguish signs within an angle of 30° to either side of the centre line of their faces without moving their heads.
- 8.2.2 Symbol Of Access** Symbol of access
- 8.2.2.1 The symbol of access shall be used to identify accessible features and facilities used by persons with disabilities.
- 8.2.2.2 The form of the symbol of access shall comply with the following:
- (a) shall consists of two elements, namely, a symbolised figure in a wheelchair and a plain square background;
 - (b) the proportional layout of the symbolised figure shall be in accordance with Figure 89;
 - (c) the colour of the symbolised figure shall be white on a blue background; and
 - (d) the symbolized figure shall face to the right.
- 8.2.2.3 The symbol of access shall be displayed:
- (a) outside the building to identify buildings with accessible facilities; and
 - (b) at areas where facilities are provided for persons with disabilities.

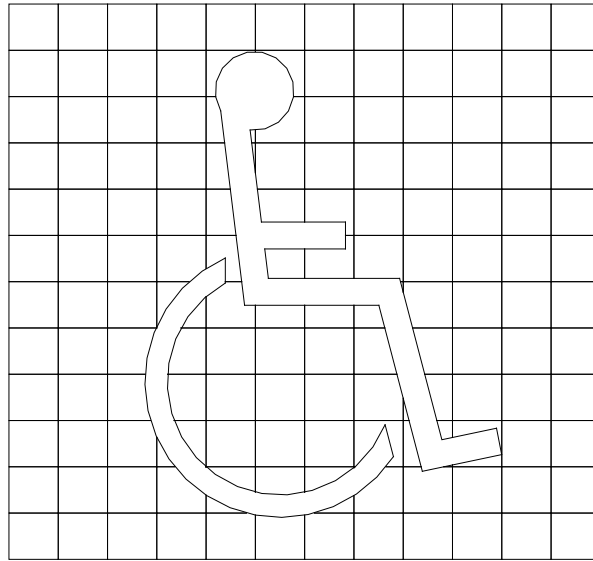
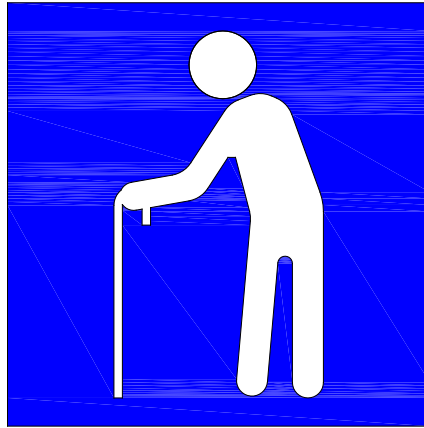

Figure 89
Symbol of Access for Persons with Disabilities

8.2.2.4 Other appropriate symbols for persons with different needs are shown in Figures 90 (a), 90 (b) and 90 (c) respectively.

Note: *The colour scheme for Figures 90 (a), 90 (b) and 90 (c) may follow according to clause 8.5.3.*



(a) Older Person or Ambulant Disabled

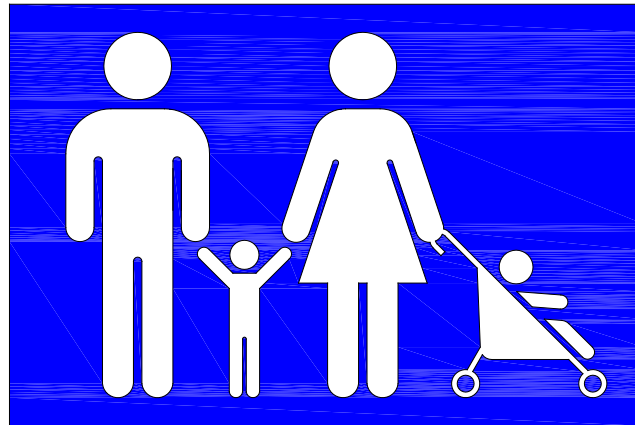

(b) Family with Young Children

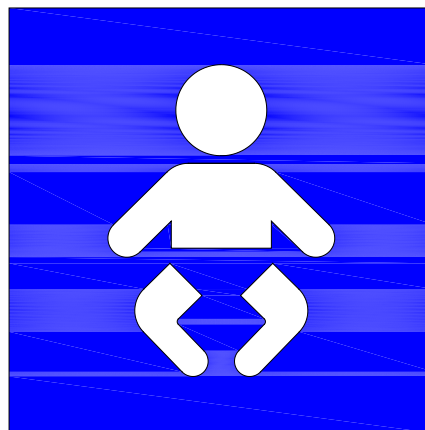

(c) Facilities for Infant

Figure 90
Examples of Symbols for Persons with Different Needs

8.3 DIRECTIONAL SIGNS

Directional signs

8.3.1 Directional signs incorporating the symbol of access, as shown in Figure 91, shall be displayed at main lobbies or passageways and at points where there is a change of direction in order to direct persons with disabilities to the various facilities such as lifts, entrances, telephone booths, toilets, vehicle parks and the like.



8.3.2 Where the location of the designated facility is not obvious or is distant from the approach viewpoints, directional signs incorporating the symbol of access, as shown in Figure 92, shall be placed along the route leading to the facility.

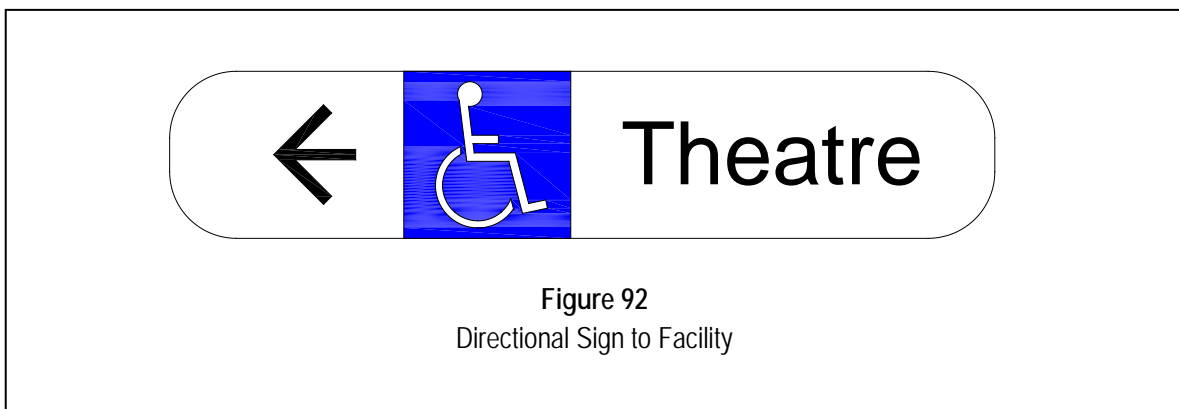

8.3.3 The content of signs shall be simple, short and easy to understand. The text and use of symbols shall be consistent throughout the building.

8.4 SERVICE IDENTIFICATION SIGNS

Service
identification
signs

- 8.4.1 Service identification signs incorporating the symbol of access, as shown in Figure 93, shall be displayed at various facilities and destinations for persons with disabilities such as lifts, entrances, telephone booths, toilets, vehicle parks, staircases and the like.

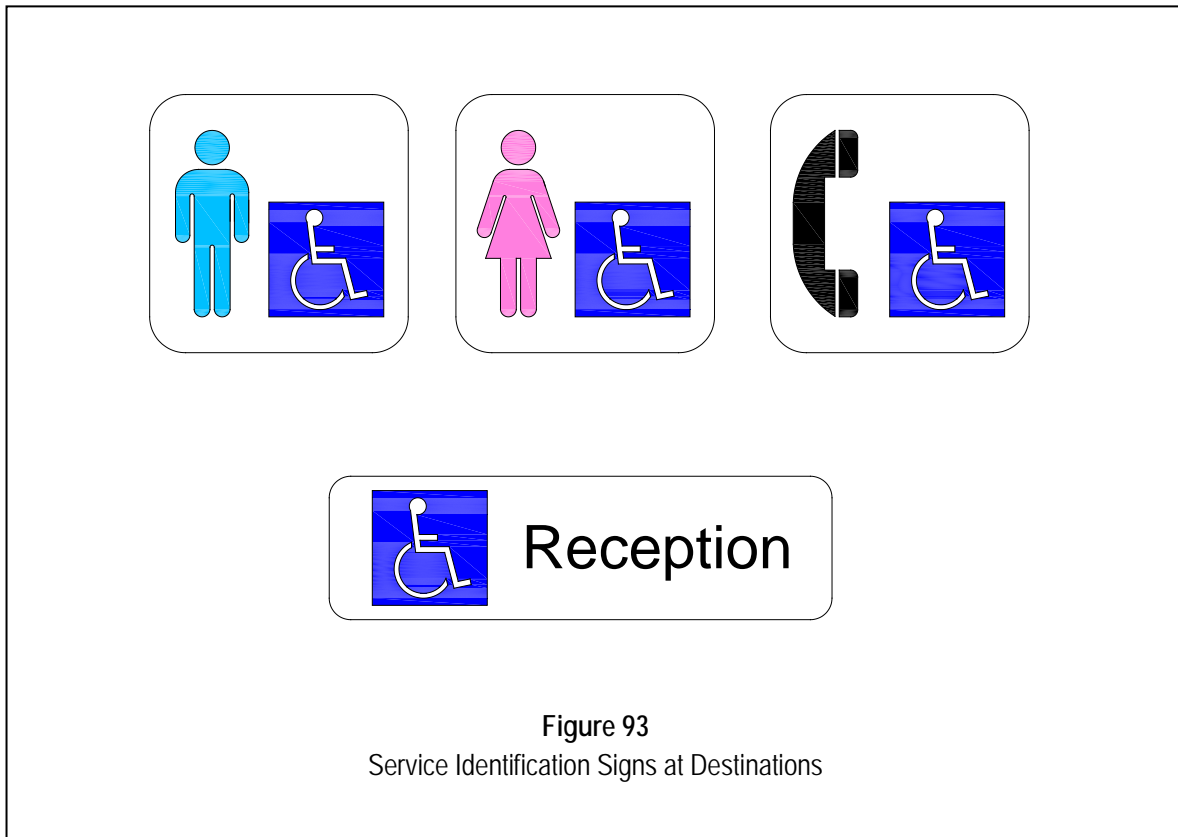

8.5 SIGNAGE

8.5.1 Text and Characters

Text and
characters

- 8.5.1.1 Letters and numbers on signs should:

- (a) use sans serif font (Helvetica, Arial, etc.); and
- (b) have Arabic numbers.

Note: *Characters include letters and numbers.*

- 8.5.1.2 The height of characters in signs for varying viewing distances should be determined in accordance with Table 7:

TABLE 7
Height of Letters

Required Viewing Distance (m)	Minimum Height of Letters (mm)
1.5	50
2.0	60
2.5	100
3.0	120
4.5	150
6.0	200
8.0	250

8.5.1.3 All text, consisting of single words or groups of words, should begin with an upper case letter and continue with lower case letters (sentence case).

8.5.1.4 All text shall be arranged with left alignment. Signs with single word may be centre justified.

8.5.2 Graphical Symbols

Graphical
Symbols

8.5.2.1 The size of graphical symbols or pictographs should be based on the intended viewing distance and determined in accordance with Table 8.

TABLE 8
Sizes of Symbols

Viewing Distance (m)	Size (mm)
Up to 7.0	60 x 60
7.0 to 18.0	100 x 100
Above 18.0	200 x 200 to 450 x 450

8.5.2.2 Arrows shall be located on the side of the sign to which they are pointing, that is, arrows pointing left shall be on the left and arrows pointing right shall be on the right.

8.5.2.3 Symbols or pictographs should be tactile in accordance with clause 8.5.5.1.

8.5.3 Colour Contrast

8.5.3.1 All characters and graphical symbols shall:

- (a) be glare free; and
- (b) have colours and tones that contrast with the following background:
 - (i) within the sign; and
 - (ii) with the surrounding or substrate.

8.5.3.2 Examples of colour contrasts are illustrated in Table 9.

TABLE 9
Colour Contrast

Background	Sign Background	Graphics
Red brick or dark stone	White	Black, dark green or dark blue
Light brick or light stone	Black or dark	White or yellow
White-washed walls	Black or dark	White or yellow
Green vegetation	White	Black, dark green or dark blue

- Note:
- (1) *To enable a sign to be located on both light and dark backgrounds or for corporate signage where the colours cannot be changed, a contrasting border should be placed around the sign.*
 - (2) *The sign shall not have any sharp edges and if fitted into a frame, the frame shall not have any sharp edges.*
 - (3) *Illuminated clear glass or acrylic signs with coloured etched legends are not acceptable for legibility reasons.*
 - (4) *Signs indicating washrooms for different sexes should have clear and simple symbols or words preferably with colour distinctions between male and female e.g. blue colour for male and pink colour for female.*

8.5.4 Location and height of signs

Location and height of signs

8.5.4.1 Signs should be located where they are clearly visible to people who are walking, standing or seated.

- 8.5.4.2 Signs to toilets shall be mounted on the wall next to the latch-side of the door at a distance of 50 mm to 100 mm from the door jamb to the side of the sign as shown in Figure 94. They shall not be mounted on the door as the sign might not be visible when the door is open. Where there is no wall space to the latch-side of the door including double-leaf doors, signs shall be placed on the nearest adjacent wall.
- 8.5.4.3 The centre line of the sign shall be at a height of 1500 mm above the floor level where they can be read equally by a standing person, or a person with visual impairment who needs to touch and read the tactile information on the sign.

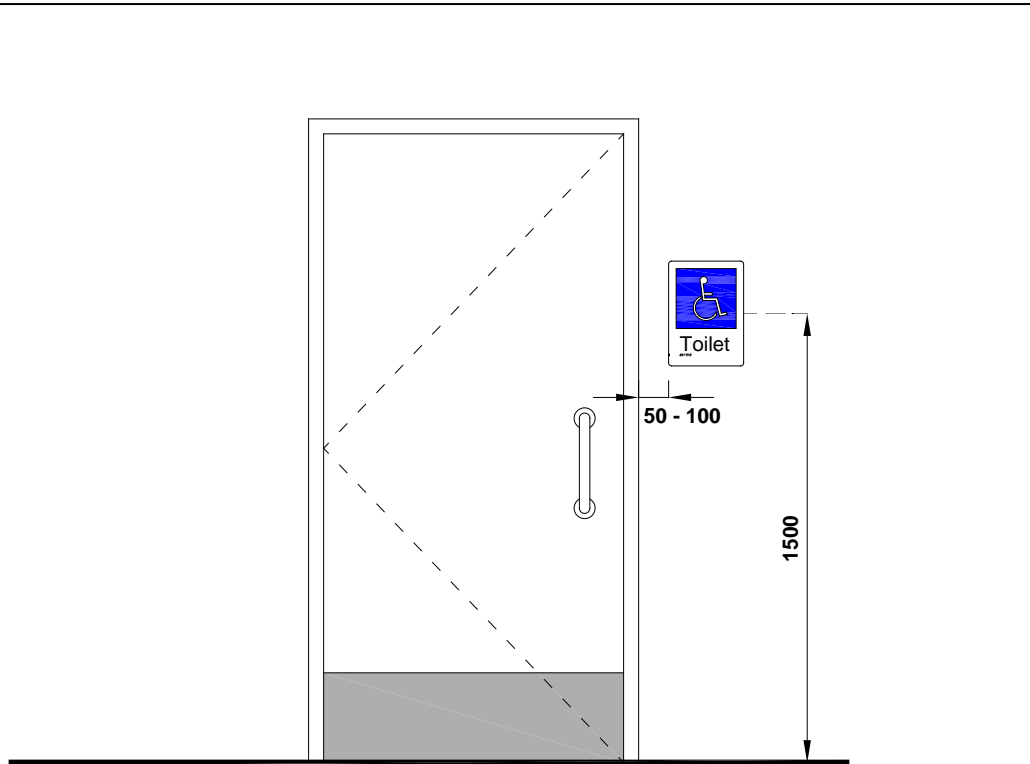

(a) Example of Signage at Accessible Individual Washroom

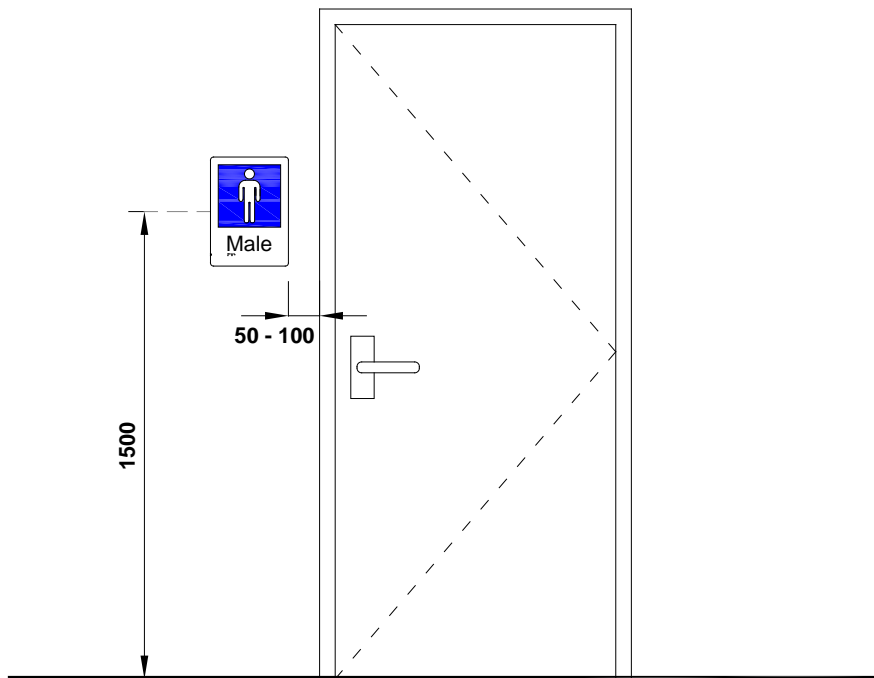

(b) Example of Signage at Male Toilet

Figure 94
Location of Door Signs on Latch Side of the Doors

- 8.5.4.4 Where signs would not be visible in a crowded situation, they should be suspended from the ceiling or projected from walls at a height of at least 2000 mm above the floor level. Suspended signs should be avoided as they are not within the field of vision for some persons with visual impairments.
- 8.5.5 **Tactile and Braille signs** Tactile and Braille signs
- 8.5.5.1 Characters, graphical symbols or pictographs on tactile signs shall:
- (a) have a raised relief contour of at least 1 mm;
 - (b) be between 16 mm and 50 mm high; and
 - (c) raised tactile characters shall comply with specifications in clause 8.5.1.1 and shall be duplicated in Braille complying with clause 8.5.5.5.
- 8.5.5.2 Tactile signs shall be mounted at a height in accordance with clause 8.5.4.3.
- 8.5.5.3 Signs with tactile and Braille information shall be used at the following areas:
- (a) Staircases complying with clause 4.11.1.2 – installed on the adjacent wall or the handrail extensions to indicate floor level or other appropriate information for wayfinding at each floor level landing; Floor identification sign
 - (b) Ramps complying with clause 4.6.14 – installed on the adjacent wall or the handrail extensions to indicate the floor level or other appropriate information for wayfinding at the floor level landing; and
 - (c) Public toilets complying with clause 5.1.7. Public toilet sign
- 8.5.5.4 Braille shall be located directly below the text and arranged with left alignment. Where an arrow is used in the sign, a small arrow shall be provided for Braille readers.
- 8.5.5.5 The Braille dot shall be raised, dome shaped and comfortable to touch. The sign shall not have any sharp edges.
- 8.5.5.6 The recommended specification for Braille on signs is shown in Figure 95 and Table 10. Specification for Braille

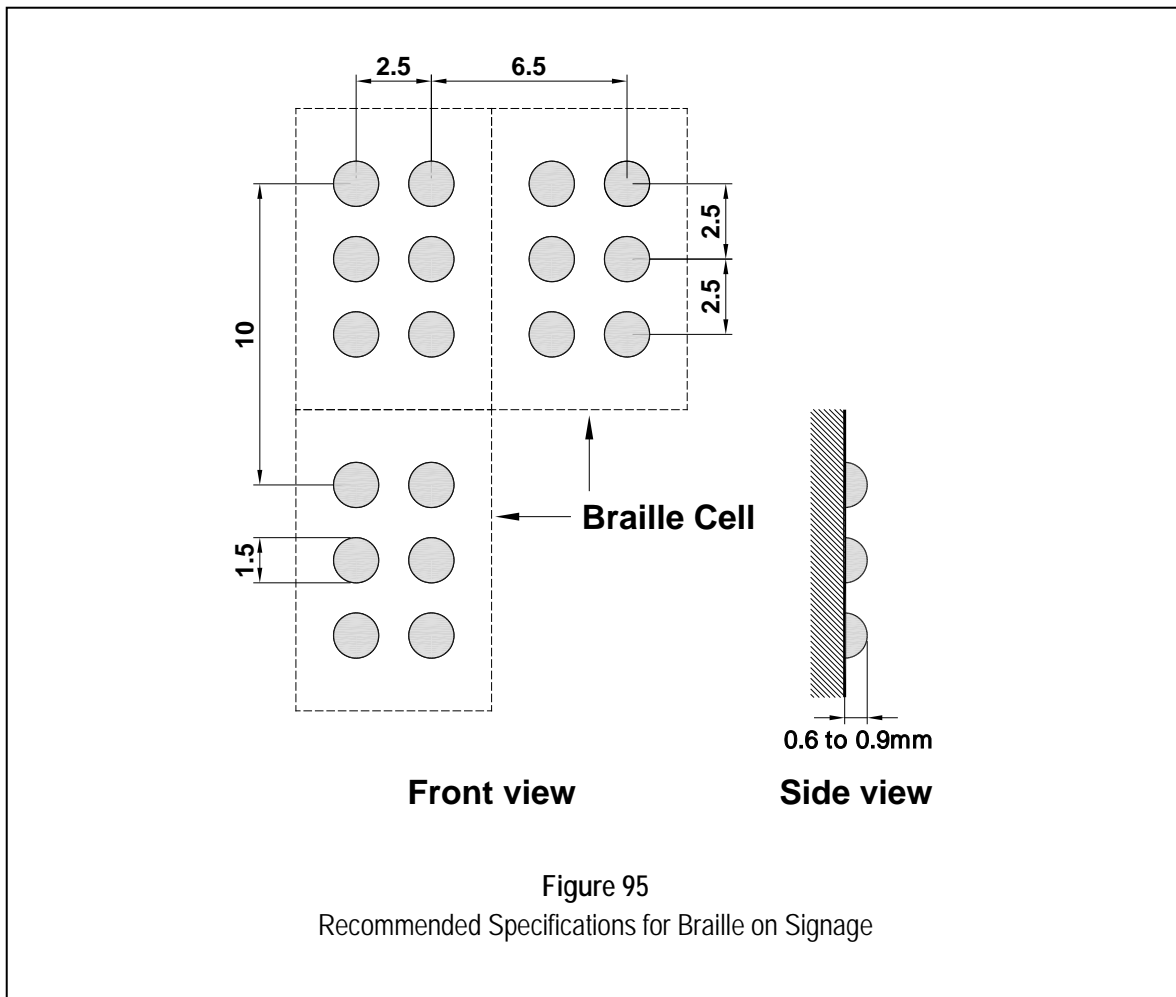

Note: All dimensions shown are in millimetres (mm).

TABLE 10
Recommended Specifications for Braille on Signage

Dot based diameter	1.5 mm
Distance between dots in same cell	2.5 mm
Distance between corresponding dots in adjacent cells	6.5 mm
Distance between corresponding dots from one cell directly below	10 mm
Dot height	0.6 to 0.9 mm

8.5.5.7 Where Braille forms a part of a sign, a marker (eg. semi-circular notch or tactile shape) shall be located at the left-hand edge of the sign to help locate the Braille message as shown in Figure 96.

Braille locator

- 8.5.6 **Illumination** Illumination
- 8.5.6.1 The minimum level of illumination on signs shall be 200 lux.
- 8.5.6.2 Signs may be illuminated by the use of back illumination but not located where the glare of lights reduces legibility.
- 8.5.7 **Audible Signs** Audible sign
- 8.5.7.1 Public address systems for performances and announcements should be clearly audible and equipped with a hearing enhancement system.

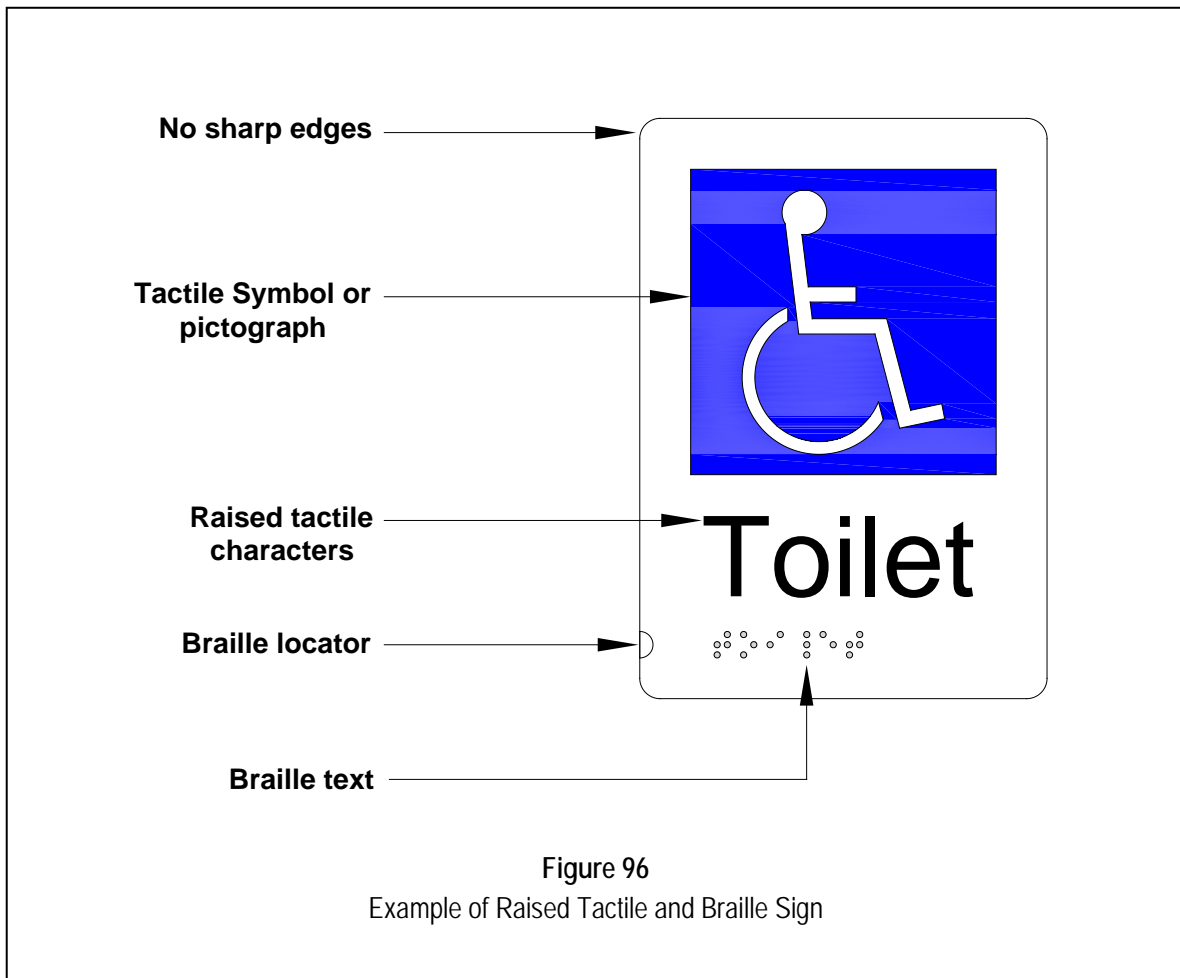

APPENDIX A

DESIGN GUIDELINES FOR FAMILY-FRIENDLY FACILITIES

- | | | |
|---|------------------------|--------|
| ▪ | Application | CI A.1 |
| ▪ | Recommended Facilities | CI A.2 |
| ▪ | Design Considerations | CI A.3 |

A.1	APPLICATION	Application
------------	--------------------	-------------

A.1.1 This Appendix contains guidelines for the design of family-friendly facilities or features in buildings. It is recommended for adoption so as to build a family-friendly environment.

A.1.2 The design guidelines are intended to apply to the following buildings which are places where families are likely to congregate:

- (a) Shopping complexes;
- (b) Supermarkets;
- (c) Places of public resort;
- (d) Sports complexes and public swimming pools;
- (e) Restaurants and eating establishments;
- (f) Markets and hawker or food centres; and
- (g) Transport interchanges and passenger terminals.

A.2	RECOMMENDED FACILITIES
------------	-------------------------------

A.2.1 The following are facilities or features that will satisfactorily serve the needs of families with infants or young children:

- (a) Child-friendly sanitary facilities;
- (b) Family washroom;
- (c) Lactation room;

- (d) Seating or resting areas;
- (e) Children's activity corners or playrooms;
- (f) Locker provisions for baby carriages and other heavy belongings;
- (g) Baby carriage and wheelchair rental facilities; and
- (h) Flexible arrangement of tables and chairs.

A.3 DESIGN CONSIDERATIONS

A.3.1 Child-friendly Sanitary Facilities

Child-friendly
sanitary
facilities

A.3.1.1 Sanitary facilities for children should be provided according to the age group that they serve and take into account the size, stature and reach in the range of children. The specifications described in this appendix are suitable for young children aged 3 to 6 years with height range of 900 mm to 1200 mm.

A.3.1.2 The following sanitary facilities should be provided in the toilets for use by young children:

- (a) at least one water-closet complying with clause A.3.1.2;
- (b) at least one urinal complying with clause A.3.1.3; and
- (c) at least one wash basin complying with clause A.3.1.4.

A.3.1.2 Water Closet

Water closet

A.3.1.2.1 At least one child-sized water closet, as illustrated in Figure A1, should be provided in each of the male and female toilets for young children. The recommended height of the water closet seat to the finished floor level is between 250 mm to 350 mm.

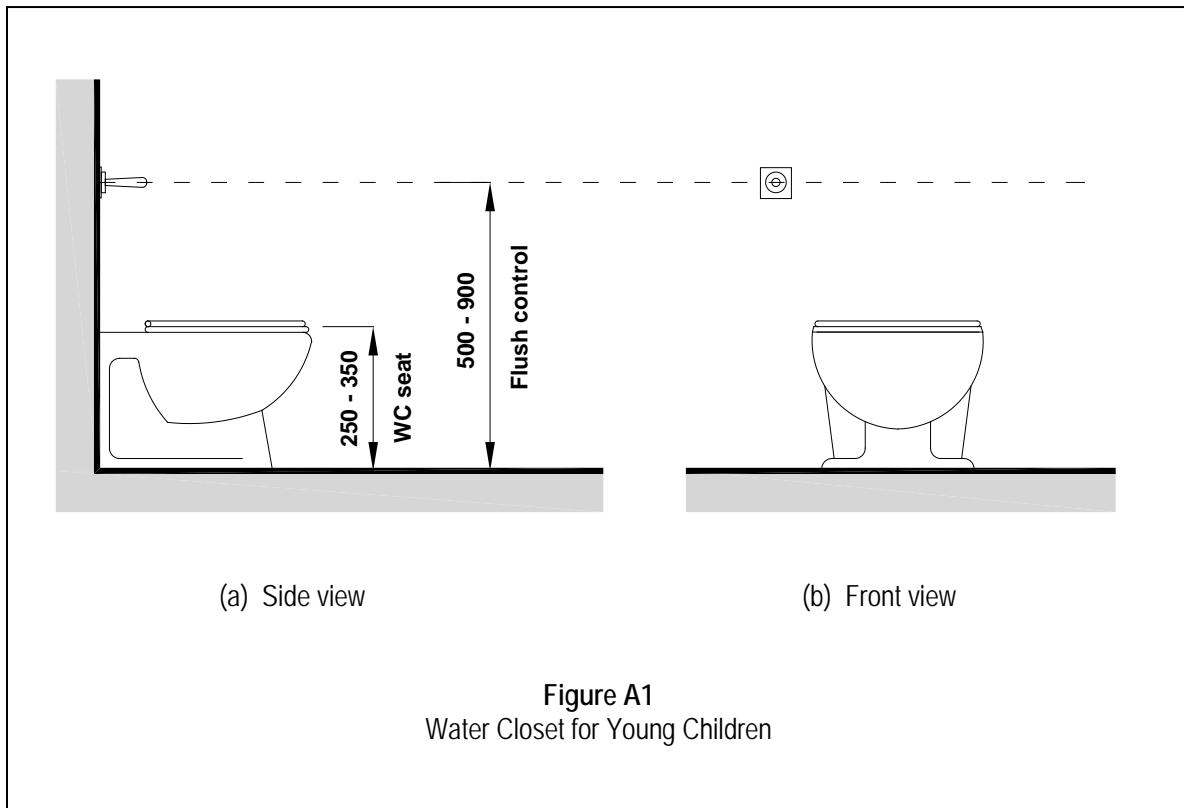

Figure A1
Water Closet for Young Children

A.3.1.2.2 For existing buildings in exceptional circumstances where it is not possible to install child-sized water closet, a seat adaptor with a small seat cover should be provided on a standard-sized water closet for use by young children. The hanger holding the seat cover should be mounted at a level that is easily accessible to young children. A portable and stable stool should also be provided as stepper for young children who may not reach the water closet.

A.3.1.2.3 The water closet compartment should be provided with bath liquid dispenser and a flexible hose with water spray head as some parents or guardians may need to clean their child.

A.3.1.3 Urinal

Urinal

A.3.1.3.1 At least one urinal mounted at a height of about 400 mm from the finished floor level, as illustrated in Figure A2, should be provided in the male toilets for young children.

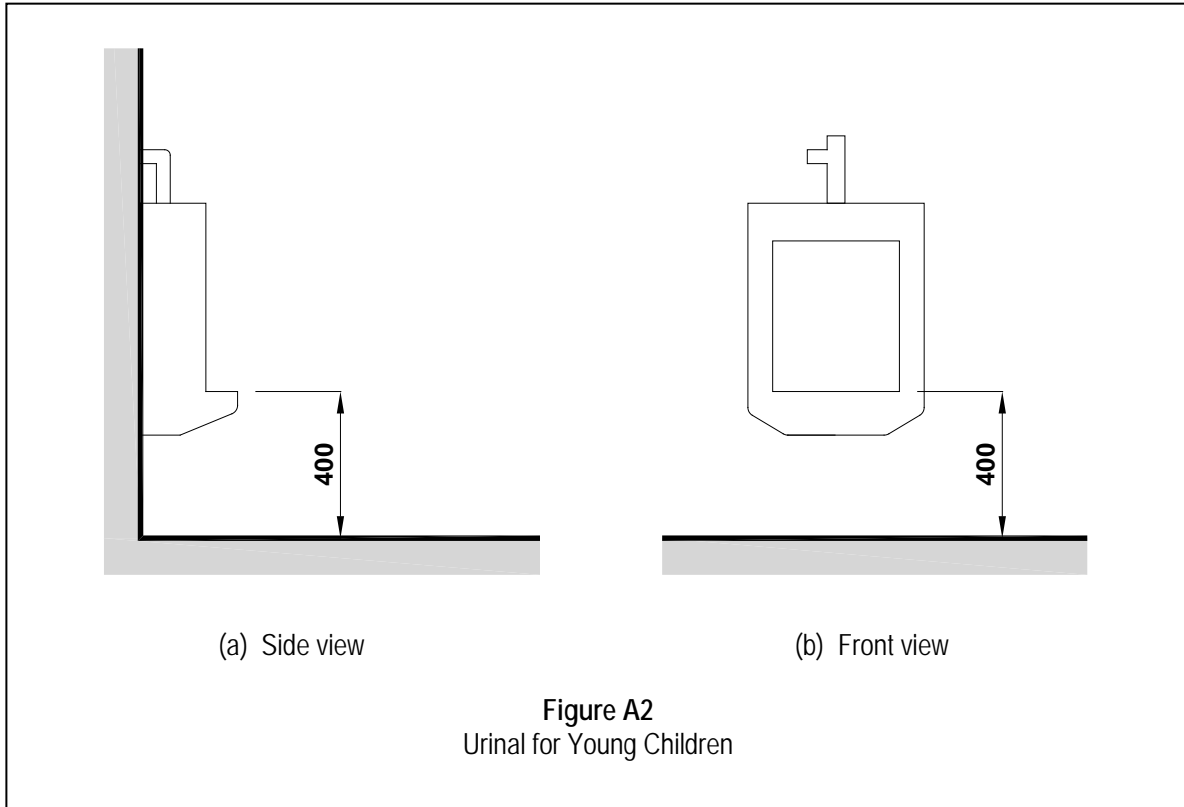

A.3.1.4 **Wash basin**

Wash basin

A.3.1.4.1 A child-sized wash basin should be provided to enable young children to wash their hands without assistance. The wash basin should be equipped with sensor operated taps. The height of the wash basin should be about 550 mm as illustrated in Figure A3.

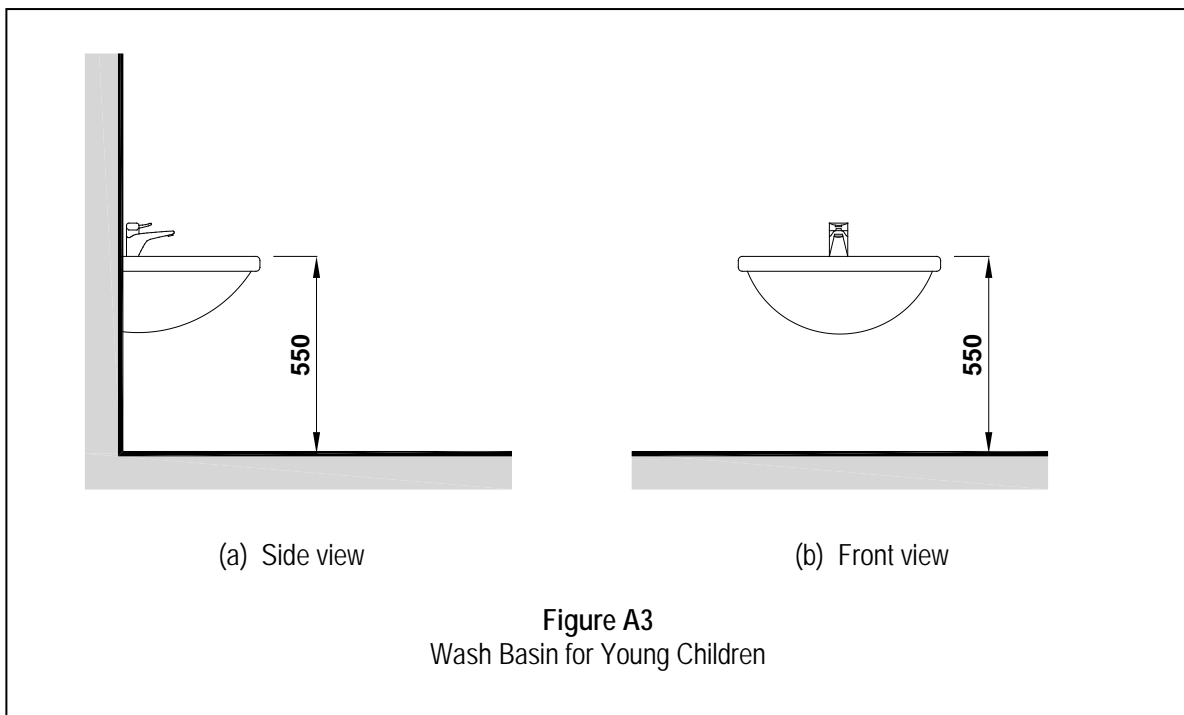

A.3.1.5 Floor finish

A.3.1.5.1 Toilets or washrooms should be provided with non-slip flooring to ensure the safety of children.

Note: *Information on Slip Resistance of Floor Finishes is given in Appendix F.*

A.3.2 Child Protection Seat

Child
protection seat

A.3.2.1 A child protection seat, as illustrated in Figure A4, should:

- (a) be equipped with straps that can be extended over shoulders and between legs to ensure the safety of a baby;
- (b) preferably be mounted on a solid wall for stability; and
- (c) take the weight of a seated child weighing up to about 20 kg.

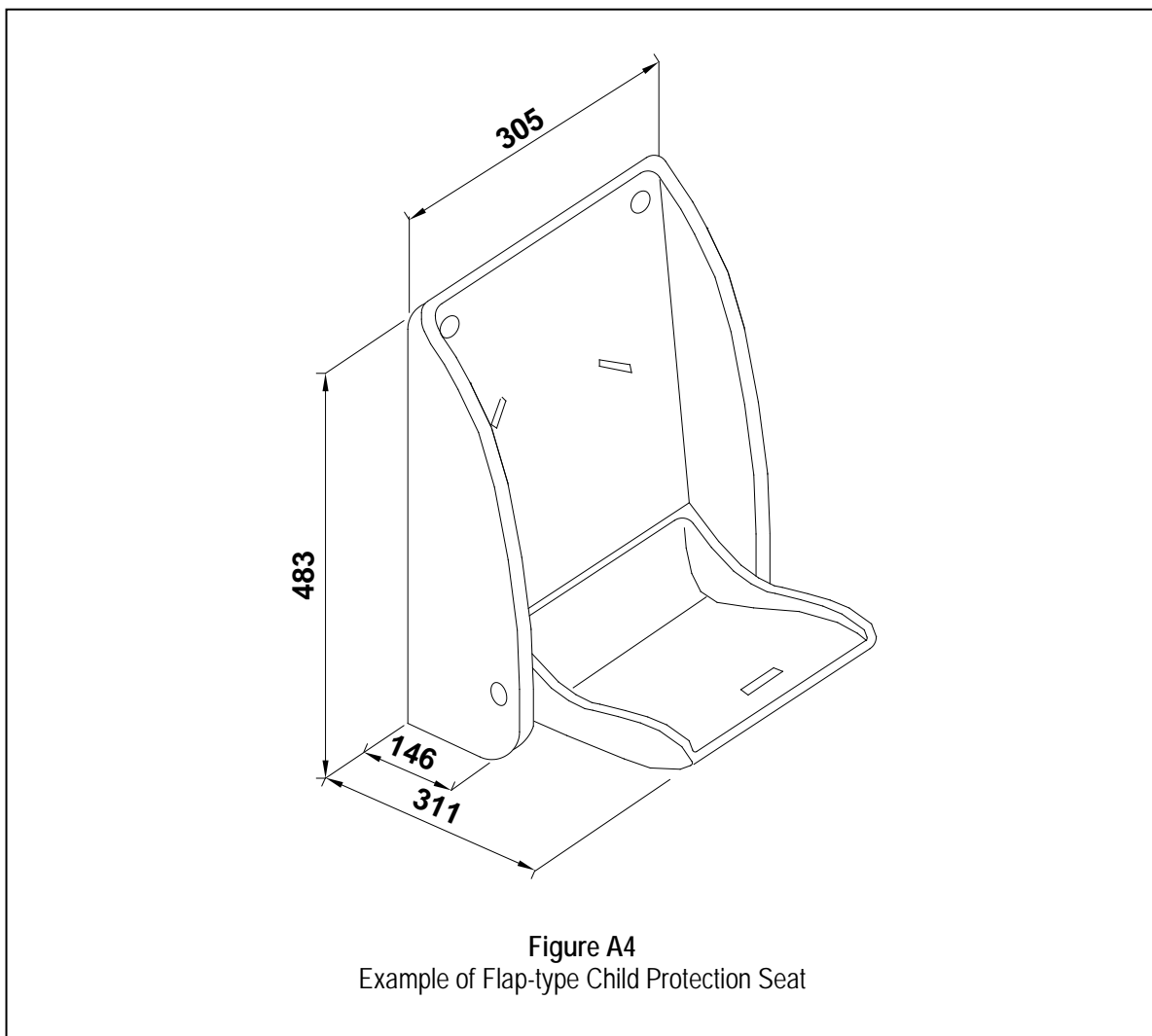

- A.3.2.2 A child protection seats should be provided in one of the water closet compartments in both male and female toilets, as shown in Figure A5, to allow parents to seat their baby safely in the washroom with them.

Note: *There should be adequate space to manoeuvre around the seated child. The bottom of the seat should be at least 400 mm above the floor for easy reach.*

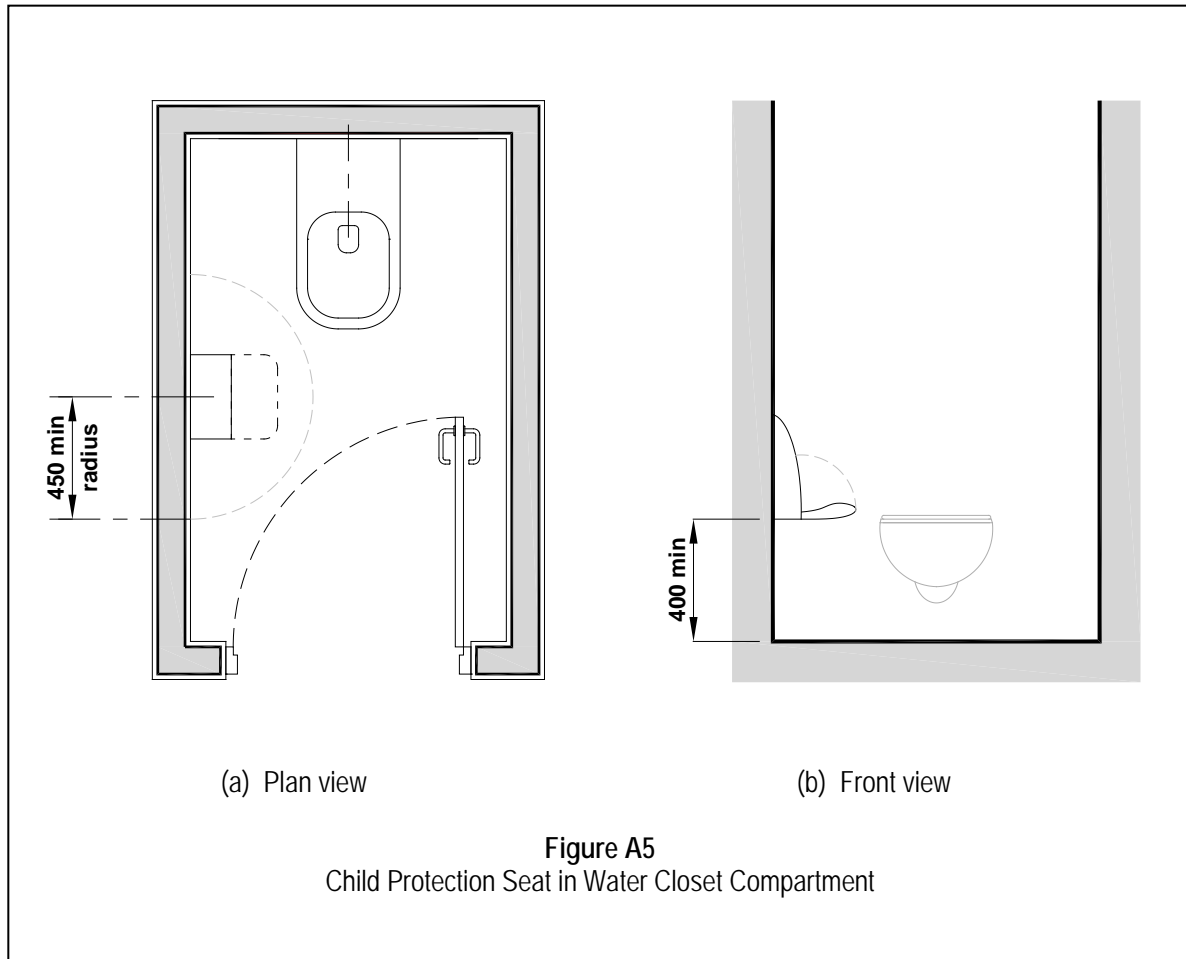

- A.3.2.3 Where a child protection seat is installed in an accessible individual washroom, a flap-type seat is recommended to avoid causing obstruction to wheelchair users as illustrated in Figure A6.

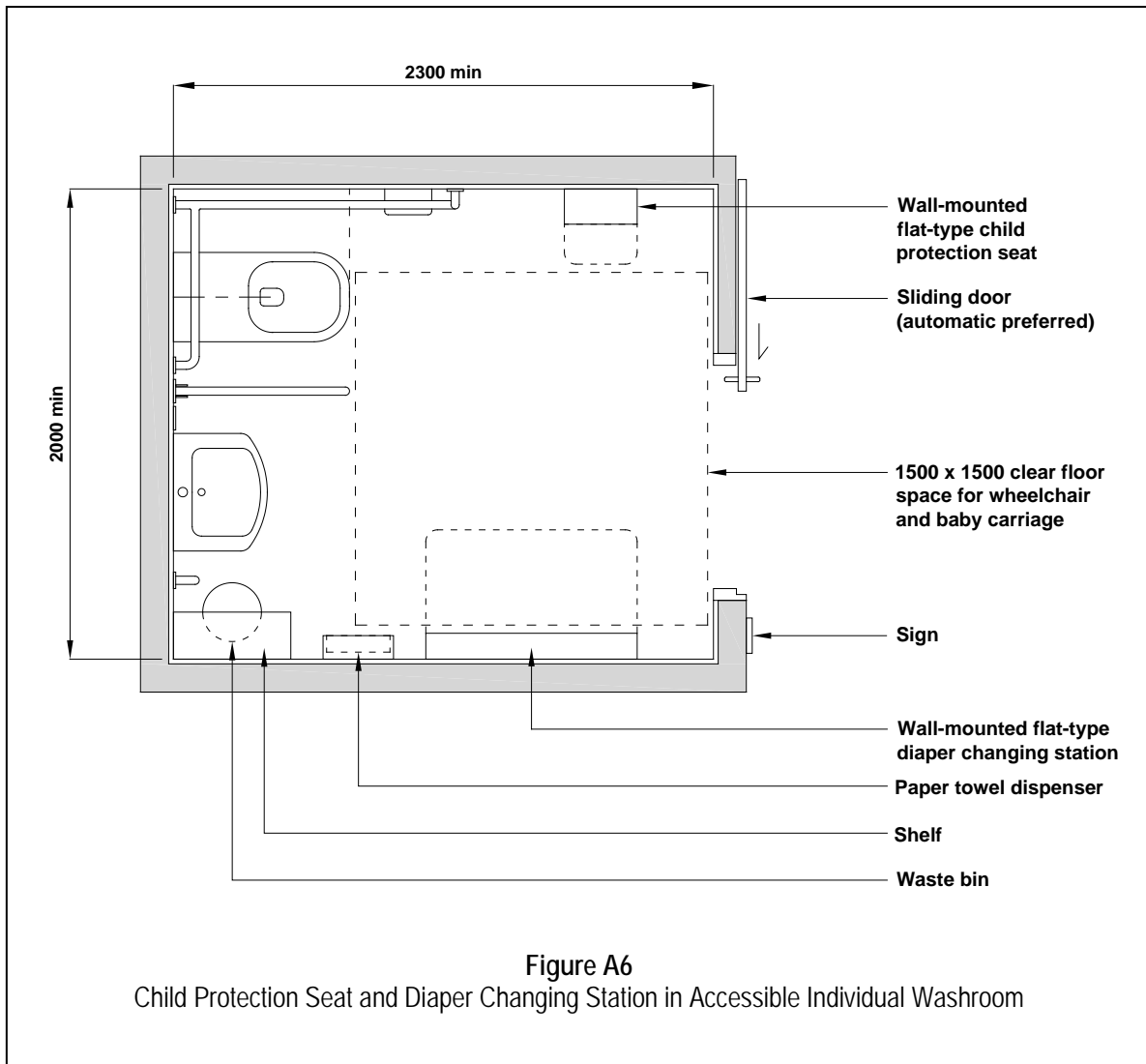

A.3.3 Diaper-changing station

Diaper-changing station

A.3.3.1 A diaper-changing station should be provided in every cluster of toilets within both male and female toilets, family washrooms or accessible individual washrooms so that both fathers and mothers can use the facility.

A.3.3.2 The diaper changing station must be stable with safety straps and barriers length-wise to ensure the safety of the infants. If it is to be located in accessible individual washrooms, a flap-type station is recommended to save space and to avoid causing obstruction to wheelchair users.

A.3.3.3 A flap-type diaper changing station as illustrated in Figure A7 should:

- (a) have a concaved changing surface to ensure comfort and protection for the child;
- (b) withstand a static weight of between 90 kg to 130 kg; and

- (c) be mounted so that the highest edge or the lip of the pull down deck when open, is between 700 mm and 850 mm above floor finish.

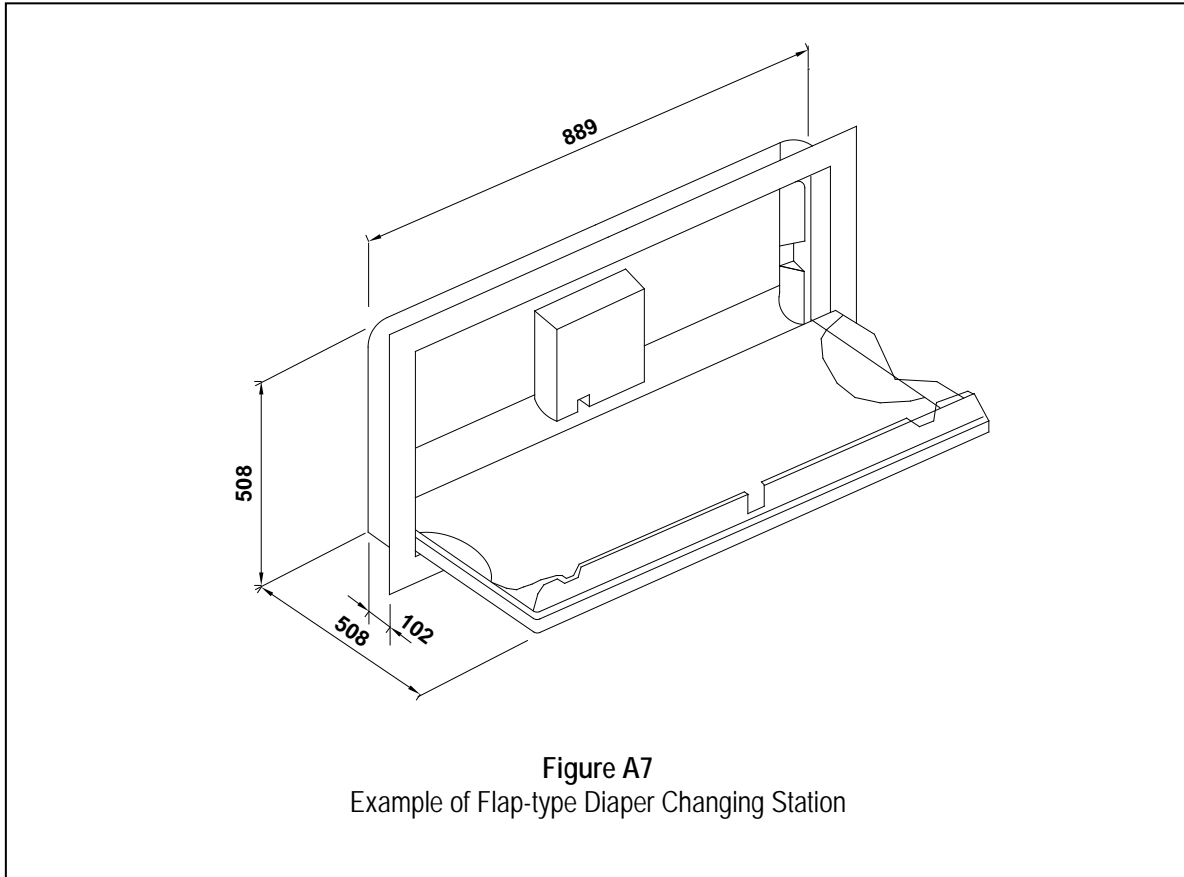

A.3.3.4 The diaper-changing station should be provided with clear instructions to facilitate safe use. Dispensers for bed linens and/or wet wipes should be provided for hygienic purposes.

A.3.4 Family Washrooms

Family washroom

A.3.4.1 The family washroom with diaper changing facilities as shown in Figure A8 should be equipped with the following:

- (a) a wash basin with liquid detergent and paper towels;
- (b) a dispenser for hot and cold water;
- (c) mirrors;
- (d) a vending machine for sanitary napkins and diapers; and
- (e) space for baby carriage parking.

Note: *An accessible family washroom will benefit a wide range of users including persons with disabilities, older persons, caregivers attending to their children, and individuals who need assistance with their toilet activities.*

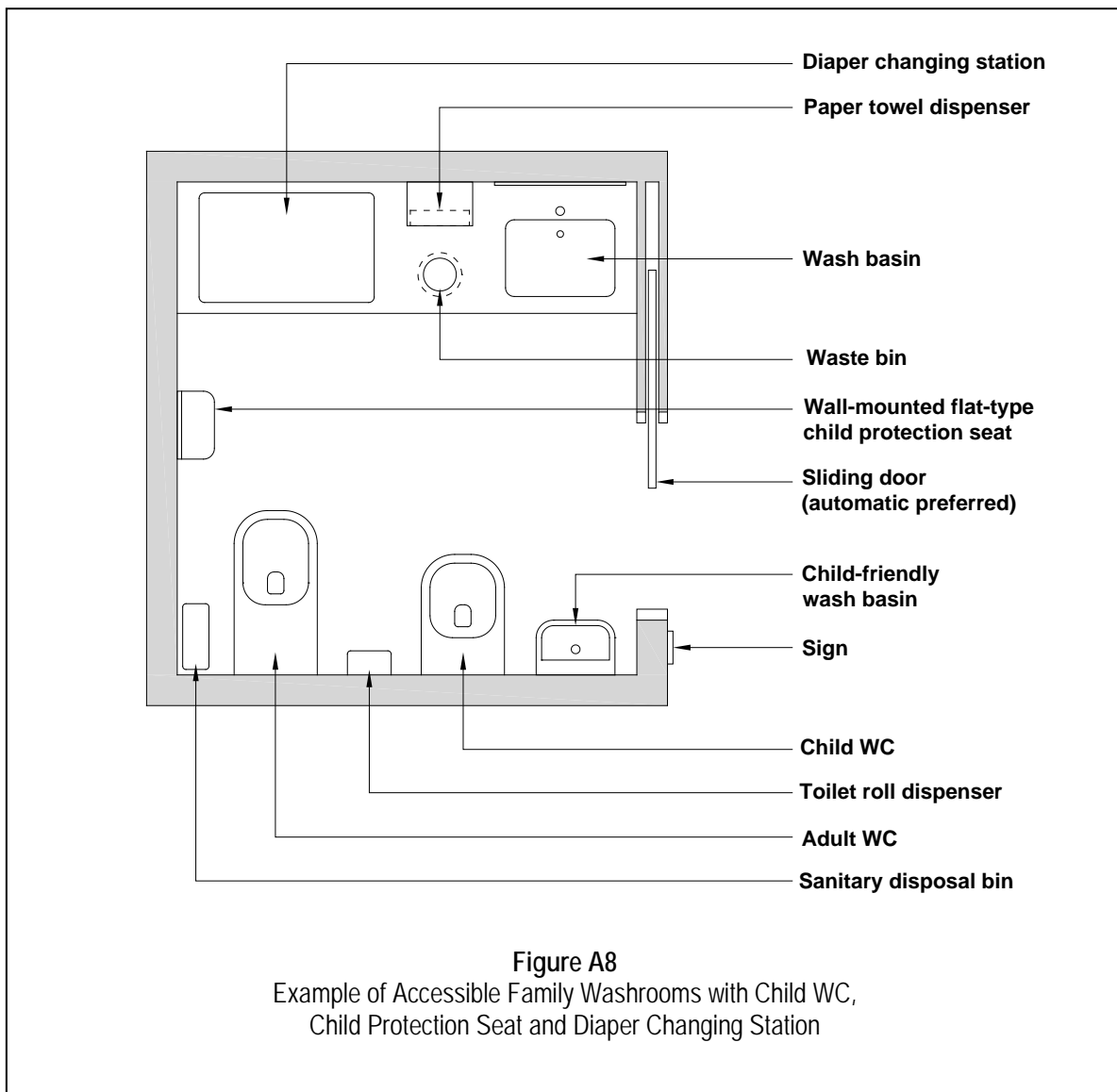

A.3.5 Lactation Rooms

Lactation room

A.3.5.1 A lactation room is a dedicated place where mothers can express milk or breastfeed their babies in a private and comfortable environment.

A.3.5.2 The number of lactation rooms to be provided should be based on the scale of the building and the needs of the building users.

A.3.5.3 A lactation room should be:

- (a) located near public amenities and easily accessible;
- (b) separated from toilets for hygienic reasons;

- (c) equipped with supporting facilities as listed in clause A.3.5.5;
- (d) well illuminated and ventilated; and
- (e) safe for infants and young children.

A.3.5.4 A separate cubicle as shown in Figure A9 with door-lock is preferred and should be made available to breastfeeding mothers only.

A.3.5.5 A lactation room should be equipped with the following:

- (a) comfortable seating, preferably of the armchair-type;
- (b) diaper changing stations in accordance with clause A.3.3;
- (c) waste bins for disposing used diapers;
- (d) wash basins with liquid detergent and paper towels;
- (e) dispensers for hot and cold water;
- (f) vending machines for beverages and diapers;
- (g) socket outlets for breast pumps;
- (h) mirrors; and
- (i) refrigerators with freezers for milk storage.

A.3.5.6 Lactation rooms in workplaces should be minimally equipped with supporting facilities as described in clause A.3.5.5 (a), (g) and (i). Example of lactation room in workplace as shown in Figure A10.

Lactation room
in workplace

A.3.5.7 Where a lactation room is provided in a workplace, it should:

- (a) be located in a calm and restful environment;
- (b) have privacy and protected from being seen by co-workers;
- (c) give consideration to comfort and provide sound privacy surrounding the lactation room as breast pumps can be noisy.

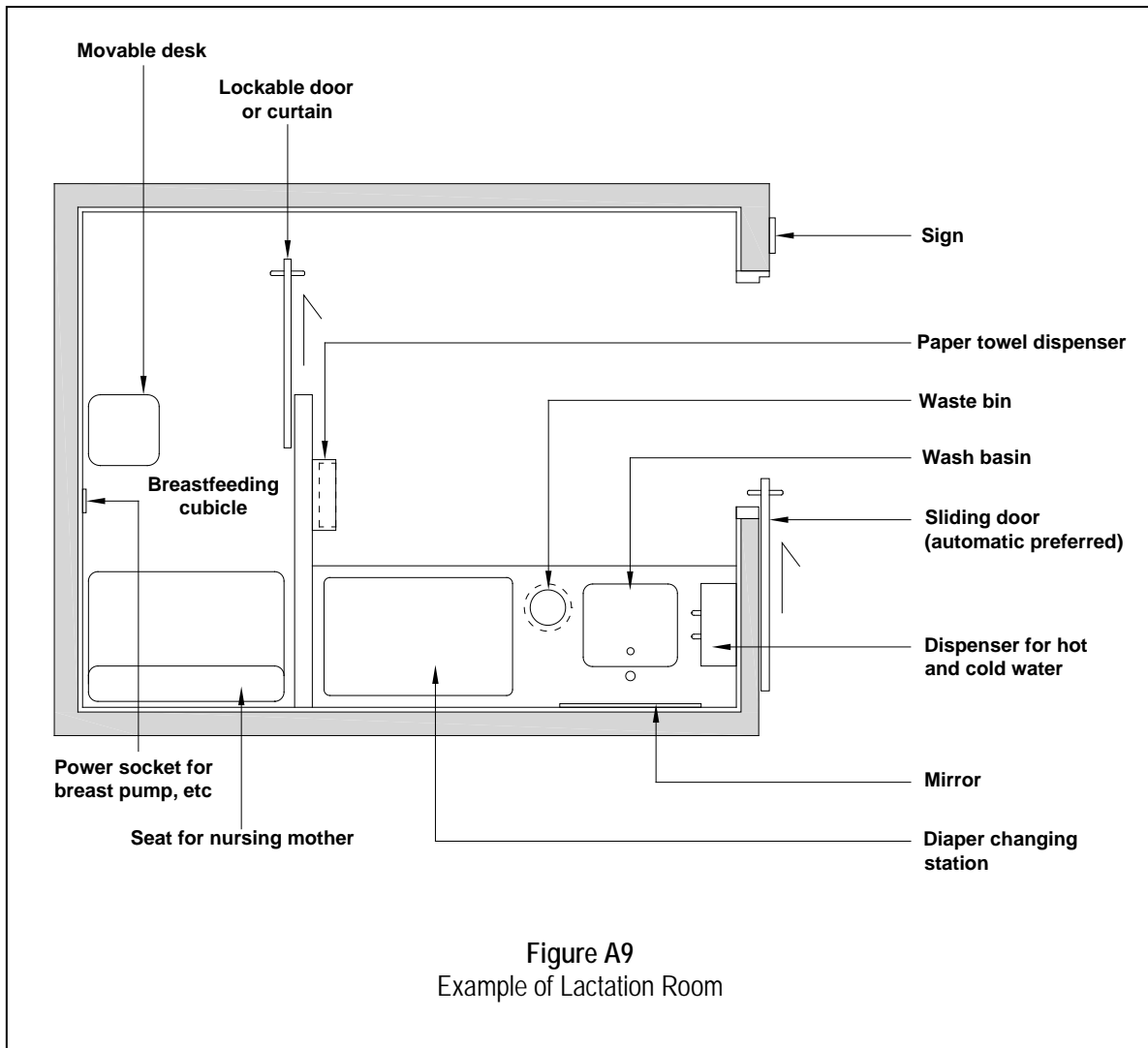

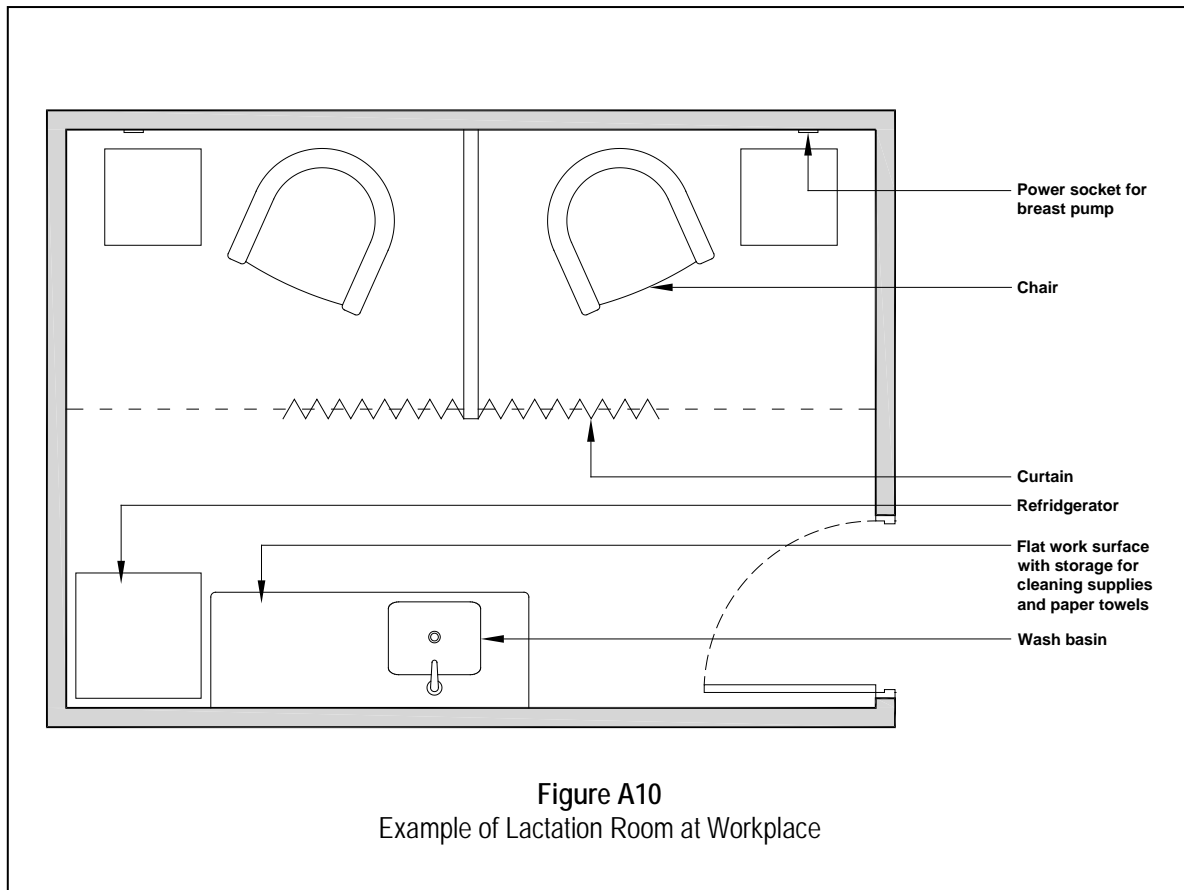

- | | | |
|---------|--|----------------------|
| A.3.6 | Seating or Resting Area | Seat or resting area |
| A.3.6.1 | Ample seating or resting areas should be provided in shopping centres and other recreational or entertainment areas for parents and their young children. | |
| A.3.7 | Children's Activity Corners or Playrooms | Children's corner |
| A.3.7.1 | Outdoor or indoor play equipment for children of various ages should be provided. The floor surface of the children's play area should be cushioned or shock-proofed to ensure the safety of the children. | |
| A.3.7.2 | Ample seats should also be provided near the play equipment for parents supervising their children. | |
| A.3.8 | Locker Provision for Baby Carriages and other heavy belongings | Locker provision |
| A.3.8.1 | Baby carriage depository services or lockers big enough to accommodate baby carriages should be provided at the main entrance of shopping centres and other recreational or entertainment areas to allow families to deposit their baby carriages and other heavy belongings. Baby carriage lockers should not be less than 1000 mm in height, 500 mm in width and 500 mm in depth as illustrated in Figure A11. | |

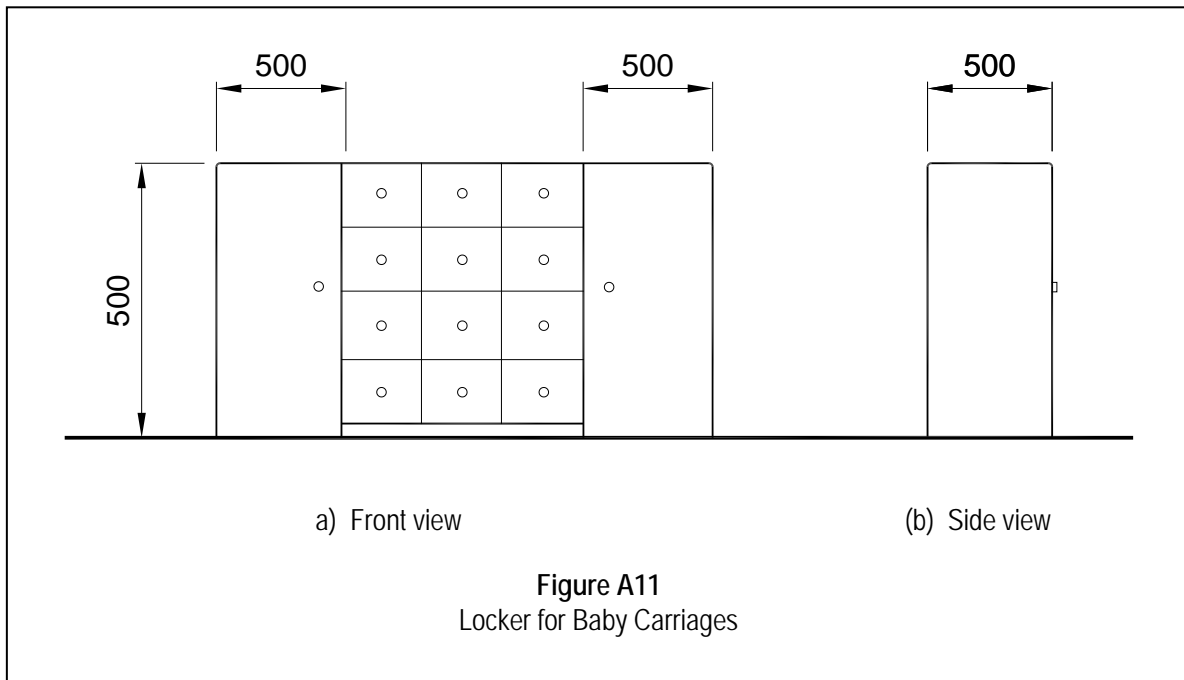

A.3.9 **Baby carriage and Wheelchair Rental Facility**

Baby carriage
and wheelchair
rental

- A.3.9.1 Renting of baby carriages and wheelchairs in shopping centres, supermarkets or other recreational or entertainment areas should be considered where applicable.

Note: *Provision of baby carriages in these areas would help to make it easier for families with infants and young children to move around the premises and provision of wheelchairs would help the elderly and ambulant disabled.*

A.3.10 **Flexible Arrangement of Tables and Chairs**

Tables and
chairs
arrangement

- A.3.10.1 A variety of table and chair arrangements or flexible arrangements of tables and chairs should be provided in eating outlets or establishments to cater to groups of different sizes.
- A.3.10.2 Where fixed seating is provided, adequate space should be provided between the seats to accommodate a baby-chair, similar to the provisions made for wheelchair users as illustrated in Figure 71 of Chapter 6.

A.3.11 **Baby-chairs**

Baby-chairs

- A.3.11.1 Adequate baby chairs with sides and backrests, and a safety belt or T-bar should be provided in eating places.
- A.3.11.2 The baby-chairs should be stable and preferably be portable.

Note: *Family-friendly facilities should be well maintained to ensure that they are clean and hygienic and are safe for young children's use.*

APPENDIX B

DESIGN GUIDELINES FOR OLDER PERSONS

▪	Ageing and Safety	CI B.1
▪	Falls in Homes	CI B.2
▪	Advantages of Considerate Design	CI B.3
▪	Mobility	CI B.4
▪	Prevention of Falls	CI B.5
▪	Design Consideration	CI B.6
▪	Top Ten Design Points	CI B.7

B.1 AGEING AND SAFETY

Safety

B.1.1 Throughout the life of a person, his level of ability increases and then declines sometimes dramatically, but more often in a progressive manner. Ageing does not necessarily bring disability, but various impairments will reduce abilities in sight, hearing, mobility, stamina and balance as well as an increased difficulty in gripping and manipulating controls, keys and other everyday tasks. All these can affect an older person in differing combinations and degrees of severity with implications on personal safety, mobility and convenience.

B.1.2 Ageing is a gradual process and these physical changes often occur almost imperceptibly so that an individual may not be aware of the potential risks of some of his habitual actions. For instance, many older persons will unthinkingly put themselves at risk by walking on shiny and slippery floor surfaces with wet feet, even though this could lead to a serious fall. Similarly, a combination of low vision and slow reaction time could lead to tripping over a step or threshold to a room, particularly in low lighting conditions.

B.2 FALLS IN THE HOME

B.2.1 A fall can be a very serious occurrence for an older person. When a younger person trips, he is usually able to recover his balance, whereas an older person will have less balance and slower reaction times. He may fall awkwardly, also causing injury. Most significantly, injuries may take much longer to heal in older persons. An accident to a frail older person can cause permanent disability or even fatality from secondary causes.

B.2.2 Fear of falling or of being embarrassed about their reduced ability to perform everyday activities may cause people to become inhibited from going out, unaccompanied, in public. At worst this may lead to withdrawal from social contact, frustration, loss of a sense of purpose and reduced quality of life.

B.3 ADVANTAGES OF CONSIDERATE DESIGN

B.3.1 Considerate design for safety and accessibility, making the home environment more suitable for older persons, can bring the following benefits:

- (a) increase convenience and make everyday tasks easier, both for the elderly and their caregivers;
- (b) reduce accidents in and around the home, thus saving on medical and social costs and prolonging the well-being of the individual;
- (c) promote personal independence in daily living, without fear of accidents;
- (d) encourage older persons to "age-in-place" without having to move out to nursing homes or other special housing until absolutely necessary;
- (e) allow individuals to continue to live in their own homes, even if they become disabled and have to use an assistive device such as a wheelchair, a walking frame, crutches and the like; and
- (f) allow for "visitability". Although the residents of a dwelling may not need wheelchair accessibility, this is worth providing because it allows for their friends and relatives to visit, whatever their disabilities or needs. The concept of visitability can also enhance the future value of the property, because it will be attractive to a wider market of potential purchasers, once the concept of "ageing-in-place" becomes a norm.

- | | | |
|------------|---|---------------------|
| B.4 | MOBILITY | Mobility |
| B.4.1 | Moving about by walking is one of the most common and natural activities that people enjoy every day. But for an older person it must not be taken for granted that this will be easy. An older person may be unstable in their gait, or be unable to see their path clearly, or be unable to recognise changes in level of floor surfaces. | |
| B.4.2 | Decreased stamina from medical conditions and frailty in old age will restrict the distances that a person can comfortably walk, particularly if there are ramps and stairs. Provision of resting places on stair landings for instance, may be desirable features. | |
| B.4.3 | Many people use “assistive devices” or “mobility aids” to help them move about more safely. These may take the form of walking sticks, zimmer frames, crutches, rollators (for ambulant disabled) or wheelchairs for those who are unable, or find it difficult to walk unaided. | |
| B.4.4 | Space for parking a wheelchair, rollator or other devices should be provided close to the entrance. In the future many older persons may use motorised scooters, in which case, suitable socket outlets should be provided for battery charging. A rollator or motorised scooter is illustrated in Figure B1. | |
| B.5 | PREVENTION OF FALLS | Falls
prevention |
| B.5.1 | Falls account for many serious accidents in homes. Most of these accidents can be avoided if designers or owners observe simple rules for safety in the built environment by reducing potential obstacles or barriers and providing adequate handrails and grab bars. | |
| B.5.2 | When older persons trip even over a small obstacle or slip on a wet or smooth floor they may not be able to recover their balance. If there is no handrail or grab bar to provide support, they might fall and seriously injure themselves. | |

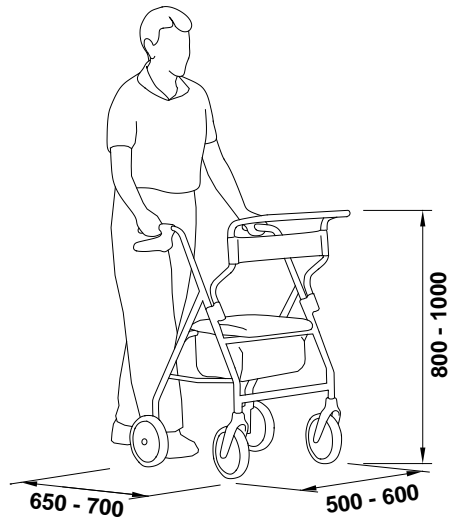

(a) Example of a rollator

Figure B1
Examples of Rollator, Electric Wheelchair and Motorised Scooter

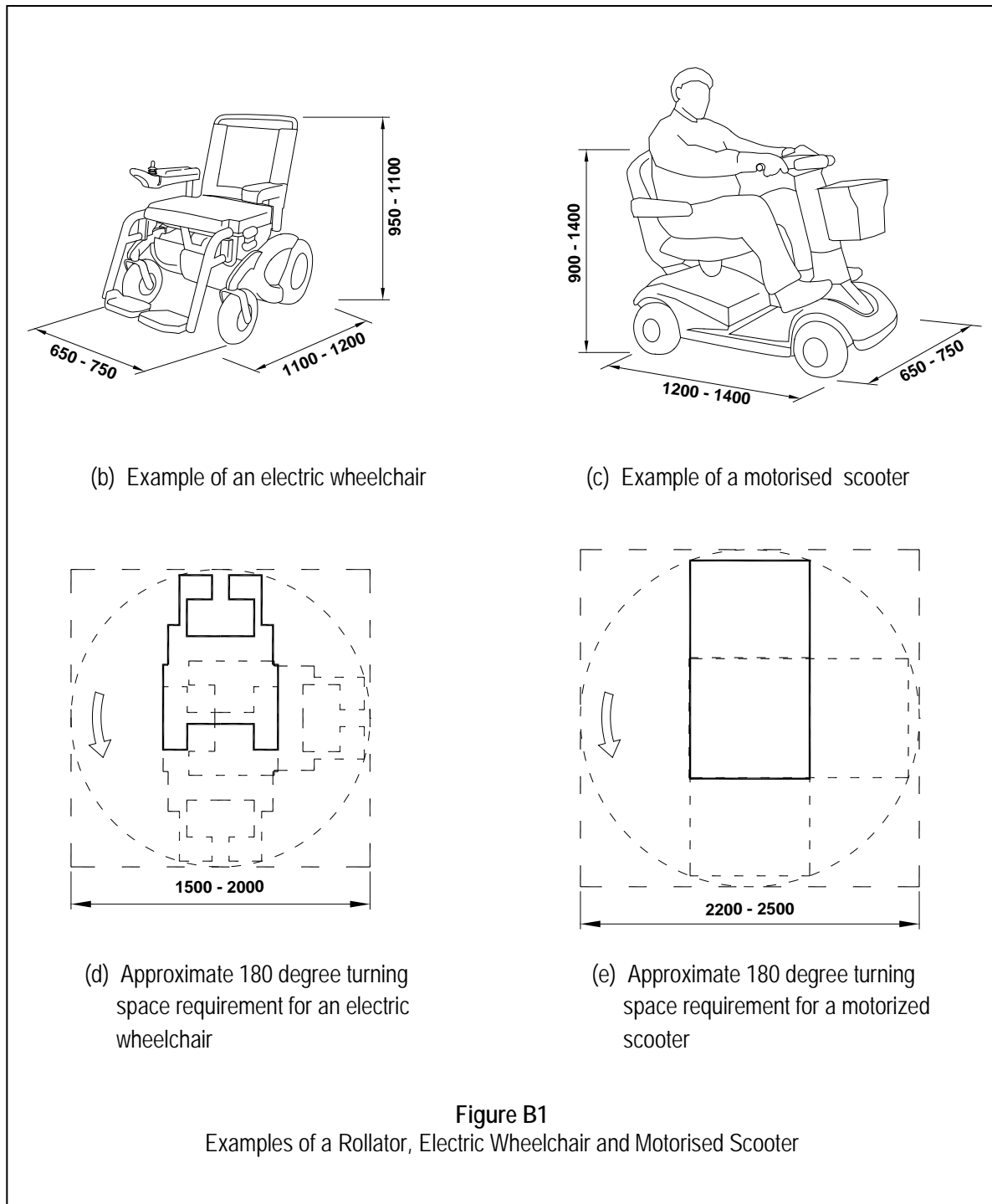

Figure B1
Examples of a Rollator, Electric Wheelchair and Motorised Scooter

B.6	DESIGN CONSIDERATION	Design consideration
B.6.1	Barrier-free and level floors	Barrier-free and level floors
B.6.1.1	Wherever possible, the design should avoid changes in floor level, such as door thresholds, steps and stairways or kerbs and small ramps, which could cause tripping. In practice, most changes in floor level are unnecessary and may be eliminated by intelligent design in the form of scupper drains covered with gratings and floor surfaces graded to a gentle fall away from door opening.	
B.6.1.2	Where changes in level are unavoidable, handrails or grab bars should always be provided, no matter how slight the level change may seem.	
B.6.1.3	Stairs should be designed in accordance with the provisions of this Code, providing correctly dimensioned handrails, contrasting colours or tones for stair nosings, both in public buildings and in private developments.	
B.6.2	Floor surfaces	Floor surfaces
B.6.2.1	Floor surfaces should comply with the provisions of clause 4.1. Shiny and reflective floors using granite, marble, glazed tiles and the like are not recommended as they could be hazardous especially when they are wet or greasy, or if they have been highly polished. Floor surfaces of kitchens, bathrooms and toilets are particularly hazardous, as these may be slippery when wet with soap solution. Non-slip floor surfaces are safer for use and should be specified. Information on slip-resistant surfaces is given in Appendix F.	
B.6.2.2	Open jointed pavers or aeration concrete blocks should be avoided at external open spaces or vehicle parks where pedestrians are expected to walk. The voids in aeration concrete blocks can catch the foot or walking aids and cause injury or a fall especially when an older person who is ambulant may already be unstable.	
B.6.3	Bending and stretching	Bending and stretching
B.6.3.1	Bending, stretching and stooping may cause an older person to fall. These risks can be minimised or avoided by having controls and operating mechanisms mounted at heights as recommended in clause 6.2 of this Code or at same level as door handles.	
B.6.3.2	Cupboards at high or low levels may be hazardous for older persons to reach with safety. Any shelf at a height that would require a person to stand on a stool or chair must be avoided.	

B.6.3.3 Leaning out of windows to open or close them or to hang out laundry poles can also be dangerous. Alternative methods should be considered when designing and specifying components including alternative methods for cleaning windows.

B.6.4 Lighting and services

Lighting and services

B.6.4.1 An older person will normally require about 2 to 3 times more illumination than a younger person and other aspects of eyesight may also become less reliable in older age.

B.6.4.2 Lighting levels of access routes, especially steps and stairways, should allow for persons with visual impairment to carry out everyday tasks and to identify edges of steps, changes in level, and other barriers as described in this Code.

B.6.4.3 Alternative light sources should be provided to illuminate any space so that if one lamp fails there is adequate light until a proper replacement can be carried out.

B.6.4.4 Two-way switch will mean that an occupant does not have to cross the room in the dark to turn the light on or off. Bedside switches are also recommended as a high proportion of older persons will need to use the toilet during the night.

B.6.4.5 Motion-sensor lights that will light up upon detection of body motion to reduce the hassle for the elderly to walk all the way to the end to turn on the light can be considered as an alternative lighting option.

B.6.4.6 Adequate illumination levels at different parts of the home including its surroundings should be in accordance with the recommendations specified in the current edition of SS 531.

B.6.5 Controls

Controls

B.6.5.1 For some older persons, gripping, turning and manipulating taps, switches, door handles and many controls can be painful or difficult. Rocker switches, lever-type controls and handles should always be used. Where these are placed in awkward positions requiring reaching such as at low or high level or across worktops, they may be hard to operate and should be avoided.

B.6.5.2 Controls may also be difficult for older persons to see and understand how to operate. Contrasting colours and larger numerals or letters are recommended.

- | | | |
|---------|---|----------------------------|
| B.6.6 | Design to prevent accidents | Accident prevention design |
| B.6.6.1 | Even with the best-designed home environment, accidents may happen. If they do, sensitive design may prevent an accident turning into a tragedy. Once older persons have fallen, they may find it difficult to get up by themselves. If they are alone, this situation can be serious as they may need assistance and possibly medical treatment. | |
| B.6.6.2 | Outward opening of doors to bathrooms and toilets can make it easier for a rescuer to enter if a person has fallen and is lying behind the door. Specifying locks and latches to bathrooms and toilets which can be opened from outside with a coin will allow for assistance in case of emergency. | |
| B.6.6.3 | By providing emergency alarm systems in the bathroom and by the bedside, operated by a floor-length pull-chord and connected to a bell or other signal in a warden's room and/or in the corridor outside the front door, a resident can summon help in an emergency. | |
| B.6.7 | Space standards | Space standards |
| B.6.7.1 | A well designed home of the future will provide adequate space for potential wheelchair use should any of the occupants become disabled. This should include doorways wide enough to allow a wheelchair to pass through and space for turning in bathrooms, kitchens and living rooms and to move around the bedroom. | |
| B.6.7.2 | For bathrooms and toilets, consideration should be given to allowing space at the side of the water closet for older persons to transfer from a wheelchair or to be assisted by their caregiver. Grab bars should be installed to facilitate transfer. | |
| B.6.7.3 | Adequate legroom should be provided under tables, worktops, wash basins and sinks for wheelchair users, giving consideration as to how they may be able to use the kitchen. | |
| B.7 | TOP TEN DESIGN POINTS | Top-ten design points |
| B.7.1 | The following are minimum provisions recommended in design for older persons: | |
| | (1) Barrier-free access without steps, thresholds or kerbs, wherever possible. | |
| | (2) Non-slip floor finishes throughout especially where water may accumulate. | |

- (3) Grab bars, especially in showers, toilets and walking areas such as corridors, or provision should be made for these to be mounted in future.
- (4) Switches, handles and controls at reachable heights preferably at the same level with door handles.
- (5) Lever handles to doors and cupboards, door keys, lever taps and controls that can be used by older persons with limited grip.
- (6) Circulation space and door widths should be adequate to allow a wheelchair to be used.
- (7) Staircases should be adequately designed including profile of treads and provision of handrails at both sides of stairways. There should be clear definition of nosings by colour contrast and adequate lighting should be provided at a recommended level of 200 lux in corridors or on stairways.
- (8) In toilet design, pedestal-type water closet seats are the preferred choice rather than the squat-type and outward opening toilet doors and adequate space to accommodate a wheelchair and a helper.
- (9) Potentially dangerous activities such as hanging of laundry out of windows, standing on furniture to reach shelves or to carry out home maintenance should be eliminated or reduced in the design.
- (10) Emergency alarm systems with pull-cord extending to floor should be provided in bathrooms and bedrooms.

B.7.2 The layout of a house suitably designed for older persons is illustrated in Figure B2.

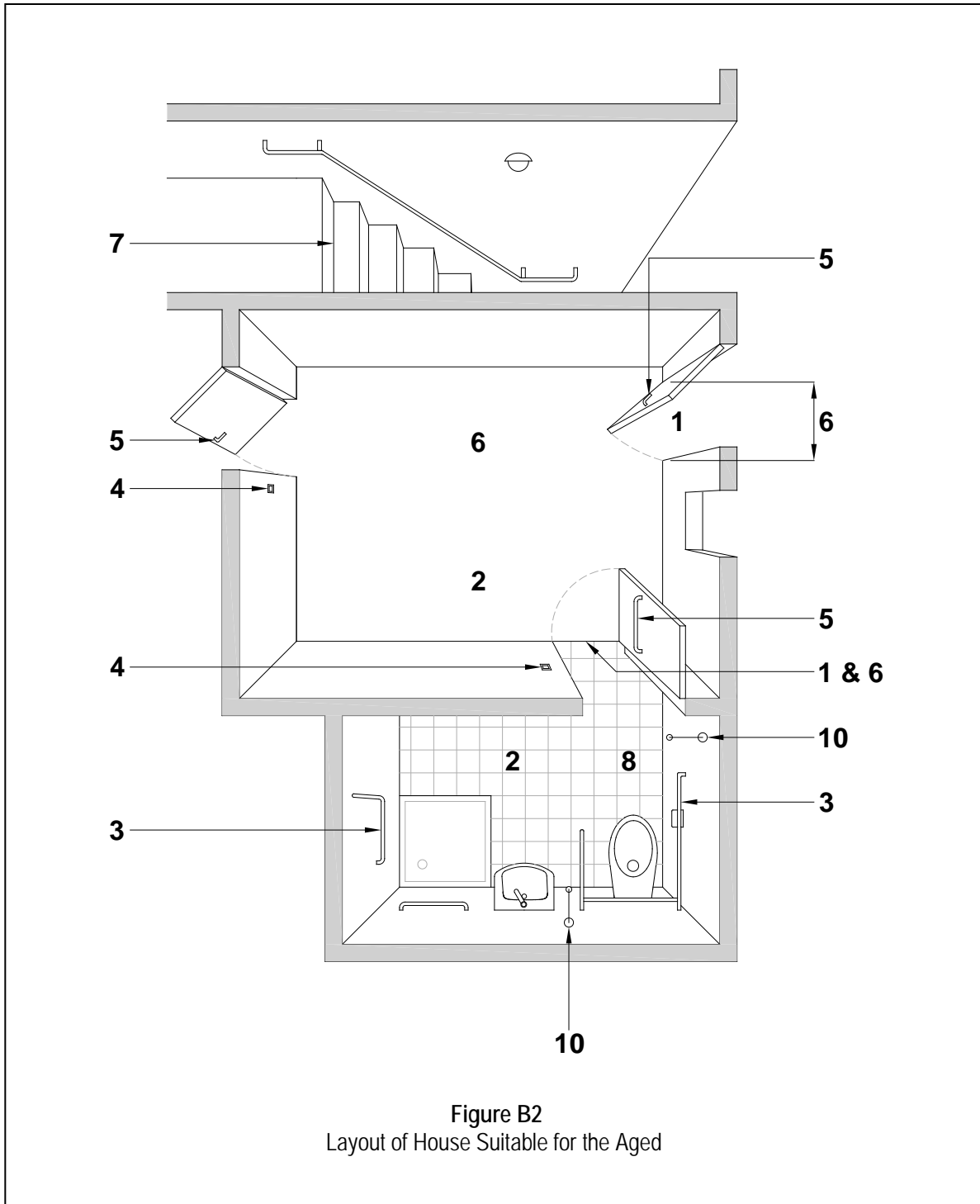

Figure B2
Layout of House Suitable for the Aged

APPENDIX C

DESIGN GUIDELINES FOR CHILDREN WITH DISABILITIES

▪	Application	CI C.1
▪	Interpretation	CI C.2
▪	Handrails and Grab bars	CI C.3
▪	Seating Spaces	CI C.4
▪	Drinking Fountains	CI C.5
▪	Sanitary Provisions	CI C.6
▪	Children’s Reach Ranges	CI C.7
▪	Lifts	CI C.8
▪	Public Telephones	CI C.9
▪	Canteens	CI C.10
▪	Computer Rooms	CI C.11
▪	Libraries	CI C.12

C.1 APPLICATION Application

C.1.1 These guidelines are intended to apply to buildings or premises, such as kindergartens, pre-schools or primary schools, where children are the principal or predominant users.

C.1.2 Where such buildings or premises are required to be made accessible to children with disabilities, it is recommended that the provisions and facilities should be designed in accordance with the details and specifications in these design guidelines.

C.2 INTERPRETATION Interpretation

C.2.1 The term “children with disabilities” in the context of these guidelines should be taken to mean children between the ages of 3 to 12 who are:

- (a) wheelchair bound; or
- (b) ambulant disabled.

C.2.2 The specifications contained in this Appendix are based on anthropometrics for children with disabilities.

C.3 HANDRAILS AND GRAB BARS

Handrails /
grab bars

- C.3.1 A second set of handrails should be provided at approach ramps and staircases at an appropriate height to assist children with disabilities and help prevent accidents.
- C.3.2 The handrails should be fixed at a maximum height of 700 mm measured vertically from the ramp surface or pitch line of the stairs to the top of the handrails.
- C.3.3 Where grab bars are required, the height should meet the need of specific age groups as recommended in Table C1.

TABLE C1
Grab Bar Height

Age (years)	Height of grab bar (mm)
3 to 6	450 to 580
7 to 12	580 to 700

- C.3.4 The grab bars should have a diameter between 30 mm to 35 mm or any shape that provides an equivalent gripping surface.

C.4 SEATING SPACES

Seating spaces

C.4.1 Clear floor space

- C.4.1.1 Seating space, such as those provided at counters, tables, or work surfaces for children in wheelchairs should have a clear floor space 900 mm wide by 1200 mm deep.

C.4.2 Clear knee space

- C.4.2.1 Where a forward approach is used, a clear knee space of at least 700 mm wide by 400 mm deep by 680 mm high should be provided.

C.4.3 Counter tops

- C.4.3.1 Writing surface or service counters should be at a height between 700 mm to 780 mm from the floor.

C.5 DRINKING FOUNTAINS Drinking fountains

C.5.1 The spout opening of a drinking fountain should be located at the front of the unit between 740 mm to 780 mm from the floor or ground surface.

C.6 SANITARY PROVISIONS Sanitary provisions

C.6.1 Water closet compartment Water closet compartment

C.6.1.1 Water closets should comply with the requirements of clause 5.6.6. The distance between the centre line of the water closet to the adjacent wall shall comply with Table C2.

TABLE C2
Water Closet Centre Lines

Age (years)	Centre line (mm)
3 to 6	300 to 350
7 to 12	350 to 450

C.6.2 Height of water closet seat

C.6.2.1 The height of water closet seat for the ambulant disabled should comply with Table C3.

TABLE C3
Toilet Seat Heights

Age (years)	Centre line (mm)
3 to 6	290 to 400
7 to 12	400 to 450

C.6.2.2 The height of a water closet seat of 450 mm to 480 mm is recommended for wheelchair users to facilitate transfer.

C.6.3 Application of specifications

C.6.3.1 The specifications of one age group should be applied consistently in the installation of a water closet and related elements.

Note: *The specifications for water closets suitable for children with disabilities should reflect the difference in size, stature and reach of children aged 3 to 12.*

C.6.4	Water closet grab bars	Water closet grab bars
C.6.4.1	<p>Water closets should be provided with grab bars that comply with the following requirements:</p> <ul style="list-style-type: none"> (a) one horizontal grab bar to be mounted at a height between 260 mm and 280 mm from the top of the water closet seat or at a height between 680 mm to 740 mm above the floor level on the side wall closest to the water closet and extending from the rear wall to at least 450 mm in front of the water closet seat; (b) one flip-up grab bar to be mounted on the side of the compartment adjacent to the water closet at a height between 680 mm to 740mm above the floor level when lowered from the wall and 360 mm to 400 mm to the centre line of the water closet; (c) a vertical or oblique bar of 400 mm to 500 mm long should be provided on the side wall closest to the water closet and the lower end should be at a height of 650 mm from the floor and 450 mm in front of the water closet seat; and (d) another horizontal grab bar to be mounted on the wall behind the water closet at a height between 680 mm and 740 mm and be at least 750 mm long. 	
C.6.5	Urinal	Urinal
C.6.5.1	At least one urinal mounted at a height of not more than 400 mm from the finished floor level, as illustrated in Figure A2, should be provided for young children.	
C.6.6	Wash basin	Wash basin
C.6.6.1	The wash basin for wheelchair users should have a knee clearance of at least 700 mm wide, 400 mm deep and 680 mm high and the rim or counter surface of the wash basin should not be higher than 780 mm.	
C.6.6.2	The height of the wash basin for ambulant disabled should not be higher than 550 mm.	
C.6.6.3	A wash basin with adjustable height is more appropriate to serve the needs of different age groups.	

C.6.7 **Mirror** Mirror

C.6.7.1 If a mirror is to be provided for both ambulant disabled and wheelchair users, the height from the floor level to the top most edge should be at least 1900 mm high with the bottom edge positioned at a height of not more than 800 mm from the floor.

C.6.7.2 A clear floor space of 900 mm by 1200 mm for a forward approach should be provided in front of the full-length mirror. No door should swing into this clear floor space.

Note: *A single full-length mirror should be able to accommodate all people, including children and adults.*

C.7 **CHILDREN'S REACH RANGES** Children reach ranges

C.7.1 Where building elements, such as coat hooks, lockers, or controls and operating mechanisms are designed for use by children with disabilities the dimensions in Tables C4 and C5 should provide guidance on reach ranges for children according to their age groups. These dimensions apply to either forward or side reaches.

TABLE C4
Forward Reach

Age (years)	Reach (low)(mm)	Reach (high)(mm)
3 to 6	500	900 to 1000
7 to 12	400	1000 to 1100

TABLE C5
Side Reach

Age (years)	Reach (low)(mm)	Reach (high)(mm)
3 to 6	500	960 to 1070
7 to 12	400	1070 to 1170

C.8	LIFTS	Lifts
C.8.1	Lift control panel	
C.8.1.1	The lift control panel for children with disabilities should be placed at a height between 800 mm and 1000 mm from the floor level.	
C.9	PUBLIC TELEPHONES	Public telephones
C.9.1	Height	
C.9.1.1	The height of the operable parts of a telephone should be between the heights of 800 mm to 1000 mm.	
C.10	CANTEENS	Canteens
C.10.1	Height of tables or counters	
C.10.1.1	The top of accessible tables and counters should be positioned from 700 mm to 780 mm above the finished floor level or ground.	
C.10.2	Seating	
C.10.2.1	If seating spaces for wheelchair users are provided at fixed tables or counters, a clear floor space of 900 mm by 1200 mm should be provided.	
C.10.3	Knee clearance	
C.10.3.1	A clear knee space of at least 700 mm wide by 400 mm deep by 680 mm high should be provided.	
C.11	COMPUTER ROOMS	Computer rooms
C.11.1	Computer table	
C.11.1.1	A clear knee space of at least 700 mm wide, 400 mm deep and 680 mm high should be provided.	
C.11.1.2	A table with adjustable height is recommended. The computer's Central Processing Unit, Monitor, Printer should be within the reach of the user in accordance with Tables C4 and C5.	

- C.12 LIBRARIES** Libraries
- C.12.1 Door/entrance**
- C.12.1.1 Where revolving doors or turnstiles are provided at an accessible entrance or along an accessible route, an auxiliary side-hung door or accessible gate should respectively be provided adjacent to the revolving doors or turnstiles complying with clauses 4.4.1.4 and 4.2.2.1.
- C.12.2 Table and counter**
- C.12.2.1 An accessible table and counter with a clear knee space of at least 700 mm wide by 400 mm deep by 680 mm high should be provided.
- C.12.2.2 The top of accessible tables and counters should be from 700 mm to 780 mm above the finish floor level or ground.
- C.12.2.3 A table with adjustable height is recommended.

APPENDIX D

DESIGN GUIDELINES FOR PERSONS WITH VISUAL
IMPAIRMENT

- Introduction CI D.1
- Visual Contrast in Building Interiors CI D.2
- Detectable Warning Surfaces CI D.3
- Application of Tactile Ground Surface Indicators CI D.4

D.1	INTRODUCTION	Application
D.1.1	Where buildings are required under clause 2.1 of Chapter 2 to be made accessible, qualified persons and designers are encouraged to adopt the recommendations in these guidelines to help create an inclusive environment to meet the needs of persons with visual impairments. It will enable them to move about independently with safety and dignity.	
D.1.2	Adequate space allowances should be provided for access routes intended for a guide dog handler and his guide dog as shown in Figure 88. Effort should also be made to consider a minimum 1200 mm width of clear opening of external doorways.	Width of access route and external doorways
D.1.3	Where permanent fixed seating arrangements are provided in accordance with clauses 2.3.5 and 2.3.9, a minimum of one seating should also be provided for a guide dog handler and his guide dog by the aisle. This would facilitate a clear path for the ushers to escort the guide dog handler and his guide dog.	Location of seating for guide dog handler
D.1.4	<p>The orientation and mobility of persons with visual impairments will be greatly enhanced by introducing the concept of :</p> <p>(a) Visual contrast in building interiors; and</p> <p>(b) Detectable warning surfaces.</p>	

D.2	VISUAL CONTRAST IN BUILDING INTERIORS	Visual contrast in building interiors
D.2.1	Vision loss and contrast	
D.2.1.1	Partial loss of vision can make it very difficult to navigate in and around the built environment, especially in unfamiliar settings. While excessive contrast can create problems of glare, inadequate contrast can make it difficult for persons with low vision to discern objects or details in the environment.	
D.2.2	Contrast and interior space	
D.2.2.1	Safe and independent use of internal spaces can be greatly enhanced by incorporating effective contrast between building elements, particularly emphasising those elements that need to be identified, operated or interpreted.	
D.2.2.2	Walls and ceilings should be finished in plain colours (not complex patterns, which can be confusing) of light tones (to help diffuse light around the room) and matt finishes (to avoid unwanted glare or reflection).	
D.2.2.3	Floors should also be relatively plain (both to avoid confusion and to allow easy location of dropped objects), not glossy and a mid-tone to contrast with walls (for example when viewed through an open doorway).	
D.2.2.4	Doors should also be a mid-tone to contrast with walls, and skirtings, architraves and door-frames should be a dark tone to help define surface junctions and openings while contrasting with floors, walls and doors.	
D.2.2.5	Door handles, light-switches, lift buttons, coat hooks and similar elements should all contrast strongly with their backgrounds. This can be achieved either by having a dark element against a light background or by mounting a light toned operating element on a dark panel, which itself contrasts with a light background.	
D.2.2.6	Soft furnishings (for curtains, chairs etc) should contrast with both walls and floors. Introduction of a simple pattern can add life and homeliness to a room but strong patterns can make it difficult to locate spectacles, keys or similar objects placed on the patterned surface.	
D.2.3	Types of contrast	Types of contrast
D.2.3.1	Contrast refers to perceptible differences between different regions of an image or scene. There are two fundamental types of contrast:	
	(a) Luminance or brightness contrast; and	

(b) Colour contrast.

D.2.4 Luminance contrast

Luminance
contrast

D.2.4.1 Luminance contrast is a measure of the relative amounts of light that are reflected from surfaces. Two quite differently coloured surfaces may have a similar luminance.

D.2.4.2 A 30% difference in luminance is generally the minimum discernible by a person with partial sight. Black and white have a 100% luminance contrast. Grey and black or grey and white have a 50% luminance contrast as shown in Figure D1.

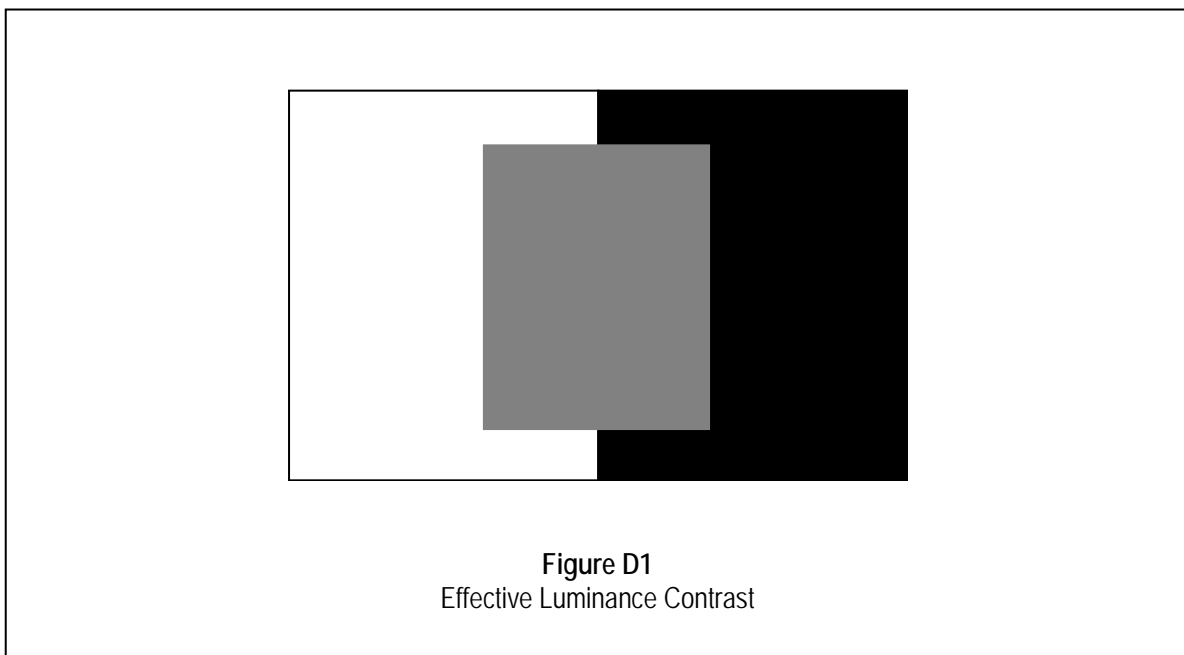

D.2.5 Colour contrast

Colour
contrast

D.2.5.1 Ageing and sight loss diminish the sensitivity of colour perception. Colours that contrast sharply to someone with normal vision may be less distinguishable to a person with low vision.

D.2.5.2 Colours can contrast on the basis of their lightness, saturation or hue. Designers can help to compensate for vision deficits by making colours differ more dramatically in all three attributes. In this context:

- (a) lightness measures the relative amount of light reflected from a colour;
- (b) saturation relates to its intensity; and
- (c) hue refers to elementary colour names, that is red, green, blue etc.

- D.2.5.3 Effective design will maximise lightness differences between foreground and background objects, and avoid using colours of similar lightness adjacent to one another, even if they differ in saturation or hue.



- D.2.5.4 Dark colours from the bottom half of the hue circle contrasts best against light colours from the top half. Avoid viewing light colours from the bottom half against dark colours from the top half as shown in Figure D2. Lightness is the most important attribute in making contrast more effective.
- D.2.5.5 Avoid contrasting hues from adjacent parts of the hue circle, especially if the colours do not contrast sharply in lightness as shown in Figure D3.

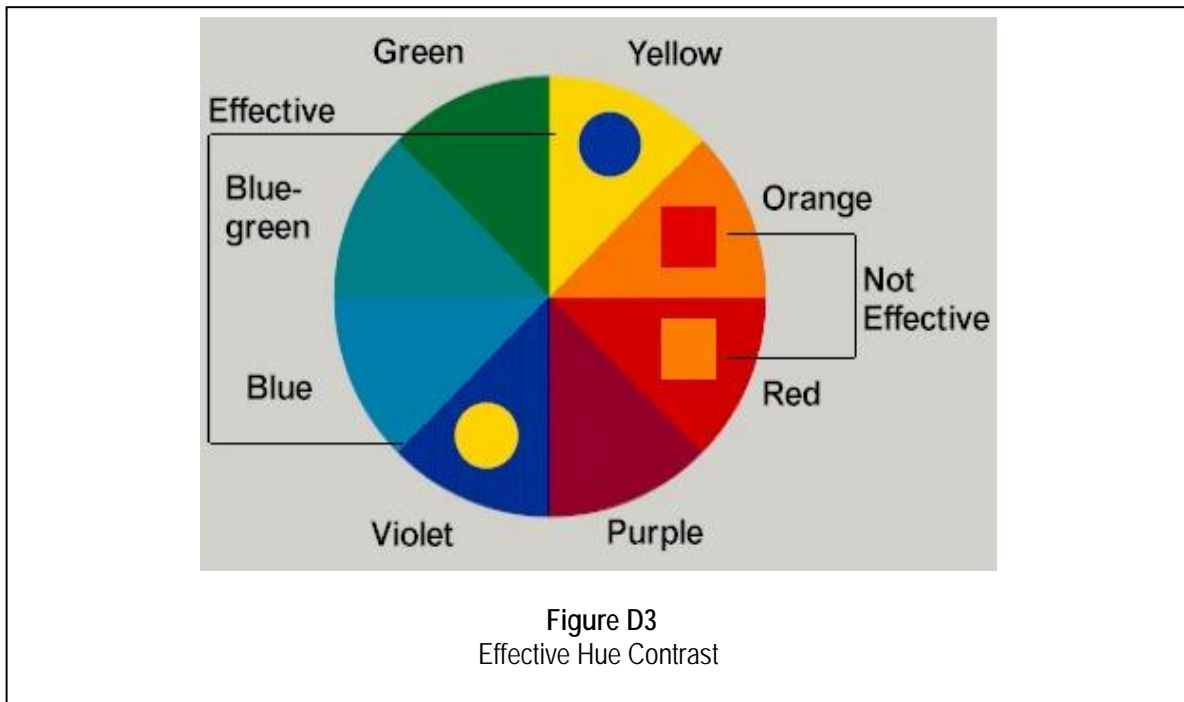

- D.2.5.6 Congenital and acquired colour deficits also make it difficult to discriminate between colours on the basis of saturation. Slate blue, for example, is a desaturated colour because it is similar to grey. A deep blue, even if it has the same lightness as slate blue, has greater saturation as shown in Figure D4.



- D.2.5.7 To someone with partial sight, the left-hand panel may appear like the right-hand panel appears to a person with normal colour vision.

D.2.6	Glare	Glare
D.2.6.1	Excessive luminance contrast between interior elements can create glare. Windows, light fittings and reflective surfaces can all impact negatively on vision if not designed appropriately.	
D.2.6.2	Direct glare can be minimised by ensuring that strong light sources, such as windows and light fittings are effectively screened.	
D.2.6.3	Reflected glare can be reduced by eliminating reflective surfaces especially on floors and walls and by attention to the location of light sources relative to mirrors, glazing and the like.	
D.2.7	Lighting	Lighting
D.2.7.1	Contrast will only be of assistance to people with sight deficits if there is an appropriate quantity and quality of illumination with which to view the contrasting elements. At low light levels, the perception of contrast diminishes.	
D.2.7.2	Lighting levels should generally be relatively uniform and about 25% higher for people with low vision. Strong directional lighting casts shadows that can mask contrasting surfaces. Significant fluctuations in illumination level can reduce visibility due to the slower adaptive response of the eye in someone with low vision.	
D.3	DETECTABLE WARNING SURFACES	Detectable warning surface
D.3.1	Mobility	
D.3.1.1	People who are blind or visually impaired strive to maintain the highest possible level of independence. Many people who are blind have a small amount of residual vision and all people with visual impairments will use whatever vision they have, together with other techniques, to find their way around.	
D.3.1.2	Some individuals will choose to travel with a sighted guide while others will choose to travel independently. For those who choose to travel independently, continual and extensive use is made of physical or other sensory cues, landmarks and mind maps.	

D.3.2 **Physical cues**

D.3.2.1 Physical structures such as buildings, walls, fences and kerbs can act as cues to assist independent travel. A person using a white cane may be able to follow a fence line from one point to another assuming there is an appropriate clear way immediately adjacent to the fence. Intermittent contact between the fence and the white cane helps to keep the person on the correct line.

D.3.2.2 Physical cues can be identified either by use of a white cane, under foot, or sometimes by eco-location.

D.3.3 **Other sensory cues**

D.3.3.1 People with low vision are well experienced at gathering and interpreting information from sources other than by sight. In the light of restricted access to visual cues, people with low vision place a much greater emphasis on information obtained via other avenues including touch, sound and smell. Detectable warning surfaces and audible information can be gathered to substitute or enhance visual information. Such information may be provided deliberately or may already occur in a given environment. Where the presence of such information is insufficient to provide adequate assistance, the deliberate provision of additional tactile or audible information may have to be considered.

D.3.4 **Landmarks**

D.3.4.1 The concept of landmarks is a very important one. By definition, landmarks are unique features in a given location. As such, they can be used to assist with orientation. Knowing the location of a landmark and the layout of its immediate surroundings will help those with low vision to orientate to the location and assist their mobility to and through the area.

D.3.5 **Mind maps**

D.3.5.1 People with low vision make extensive use of mind maps. Even where high quality access features have been provided, it will still be necessary for someone who is blind to be familiar with the location before they would be able to access it independently. Having been to the location with a sighted guide, or having had it described to them, the person can build a mind map for future reference. This is a very common form of orientation and an effective mobility technique.

- D.3.6 **Clear continuous accessible path of travel**
- D.3.6.1 In essence, a clear continuous accessible path of travel is one that provides a dedicated pedestrian space which is free from barriers, hazards or obstructions.
- D.3.7 **Types of tactile ground surface indicators** Types of tactile ground surface indicators
- D.3.7.1 This is one form of tactile indicators which, in essence, provides the blind or visually impaired a physical cue. It is detectable either under foot or by the use of a white cane. Tactile ground surface indicators are only one source, amongst many, of orientation information. Unlike some other tactile indicators which are basically generic in nature, tactile ground surface indicators have a specific function and impart specific information about the immediate surroundings.
- D.3.7.2 Tactile ground surface indicators act as, and are interpreted as, landmarks. There are two types of tactile ground surface indicators:
- (a) warning indicators; and
 - (b) directional indicators.
- D.3.8 **Warning indicators** Warning indicators
- D.3.8.1 Warning indicators, as the name suggests, warn of either a hazard or a destination. For example, a warning indicator near the edge of a staircase landing warns of the edge of the landing which otherwise would pose a significant hazard to a pedestrian with low vision. As the person approaches the edge, the tactile warning treatment will be identified either by the white cane or under foot thus warning of an impending drop to the staircase.
- D.3.8.2 The dimensions of a warning indicator are shown in Figure D5.

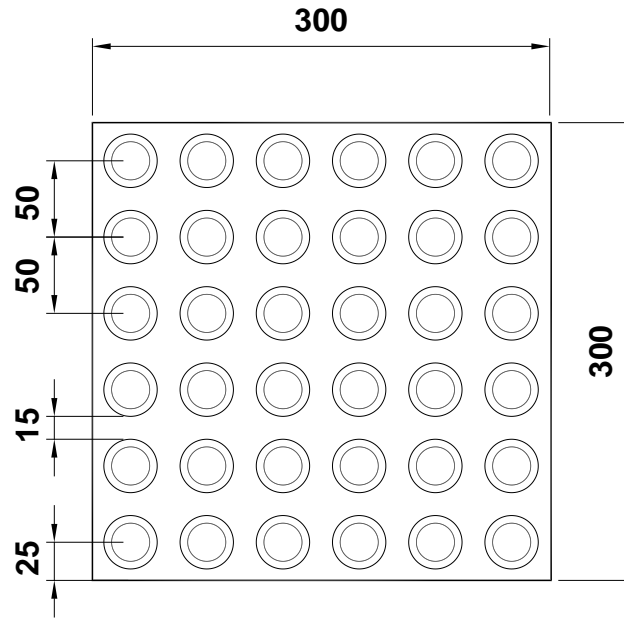

(a) Top view

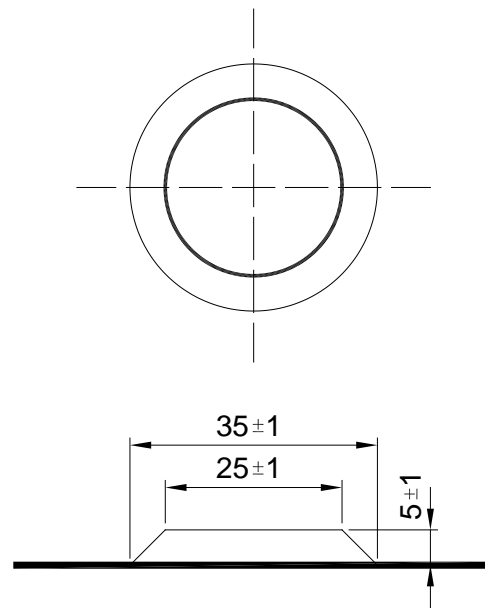

(b) Stud detail

Figure D5
Warning Indicators

D.3.9 Directional indicators

Directional indicators

D.3.9.1 Directional indicators are used to direct the user from one point to another along a safe path of travel. They are only required when there are insufficient cues from other sources to achieve the same result. For example, a directional indicator may be used in an open pedestrian plaza to indicate a clear path of travel in the absence of any other cues.

D.3.9.2 The dimensions of a directional indicator are shown in Figure D6.

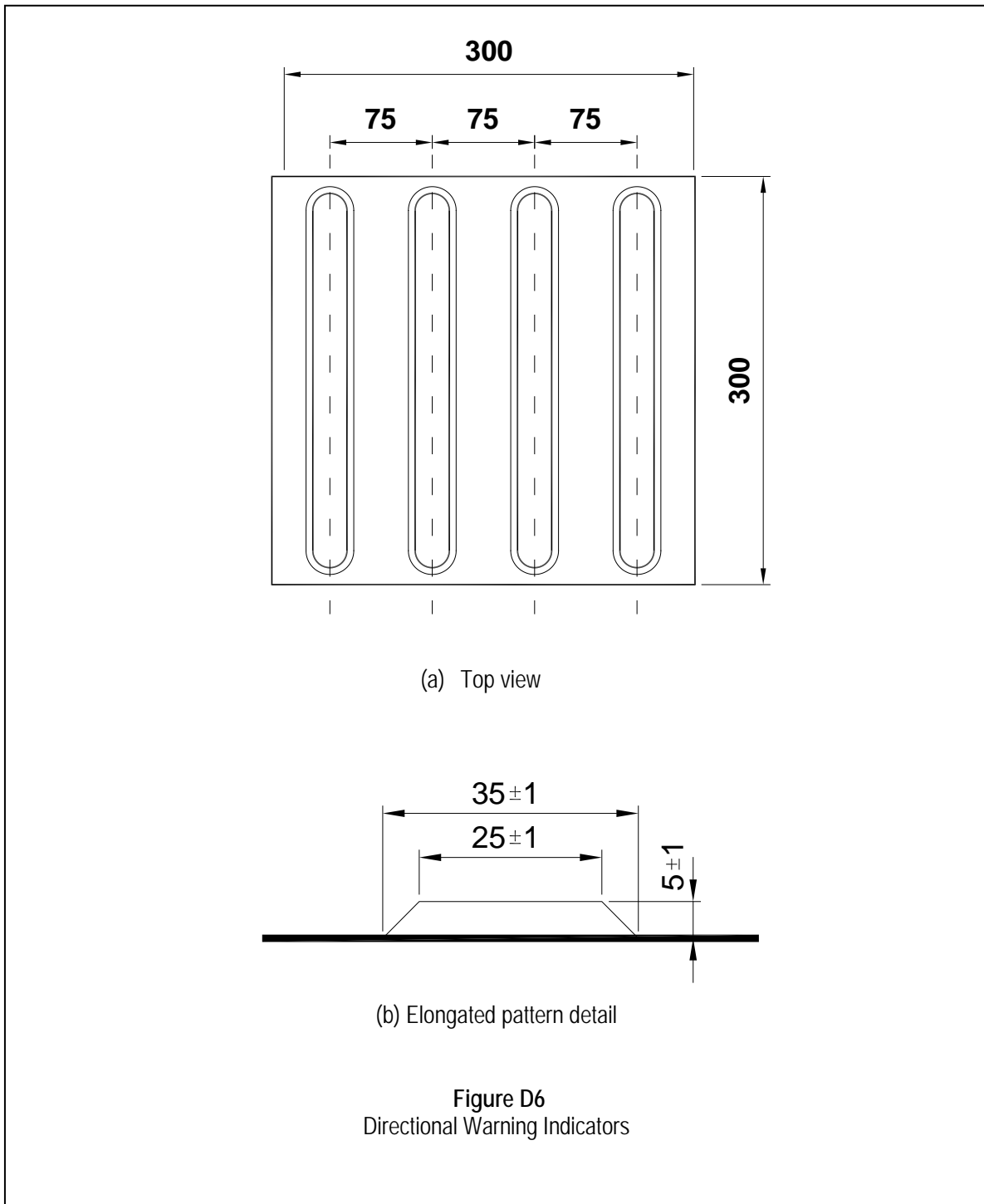

- D.3.10 **Position of tactile ground surface indicators** Position of tactile ground surface indicators
- D.3.10.1 The decision to apply tactile ground surface indicators will always have to be made in light of the particular circumstances applicable at any given site. In making such decisions, consideration should be given to the orientation and mobility strategies and techniques adopted by people with low vision (such as those discussed above) and the potential hazards and barriers existing at a given location. However, there are some obvious situations where tactile ground surface indicators must be applied.
- D.3.10.2 Warning treatment may be required at:
- (a) hazardous locations, such as steps, stairs, railway platforms, pedestrian crossings and wharves; and
 - (b) destinations to provide information about the location of amenities such as ticketing machines, phone booths and the like.
- D.3.10.3 Directional treatment may be required to assist with:
- (a) direction, that is, to indicate a clear continuous accessible path of travel; and
 - (b) location, that is, to provide assistance to locate a target such as a pedestrian crossing, entrance to a public building, ticketing machine or phone booth.
- D.3.11 **Principles of application** Principles of application
- D.3.11.1 When considering the application of tactile ground surface indicators, four major principles shall be taken into consideration.
- D.3.12 **Minimalist application**
- D.3.12.1 Tactile ground surface indicators acts as landmarks. As such, its application must be targeted and minimised as far as possible. Widespread ad hoc application of tactile ground surface indicators will confuse rather than inform, and will compromise the effectiveness of the specific cue being provided.

D.3.13 Dimensions

D.3.13.1 The dimensions of the treatment are critical. Remembering that tactile ground surface indicators will be identified under foot, it is important to ensure that a minimum depth of treatment is applied. To be detectable under foot, the treatment must make contact with the ball of the foot. To ensure this will always occur, treatments must have a minimum depth of 600 mm in the direction of travel. This dimension applies to both warning and direction treatments at their initial point of identification.

D.3.14 Colour and Luminance contrast

D.3.14.1 Tactile ground surface indicators should be coloured and luminance contrasted against their surrounding surfaces. This will greatly assist those using their residual vision to move around.

D.3.14.2 Many people with low vision also have difficulty distinguishing between different colours particularly if they appear next to each other. For example, the "tomato effect", that is red on green, does not provide adequate luminance contrast and as such will be extremely difficult to identify. For this reason, a minimum luminance contrast of 30% is required to fulfill this principle. However, a luminance contrast of 50% is recommended.

D.3.14.3 There are different ways in which tactile ground surface indicators can be installed and with different luminance contrasts. Tactile ground surface indicators can be installed as:

- (a) integrated units : tile-like units where the background and raised domes are made of the same material;
- (b) discrete units : separate domes installed to provide the effect of a tile on an existing surface. The raised domes are inserted into the background surface; and
- (c) composite discrete units : similar to discrete with the exception that the truncated sides of the domes or the directional markers are a different colour to the upper surface. The composite discrete tactile ground surface indicator is generally manufactured this way to incorporate a superior slip resistant surface.

D.3.14.4 The luminance contrast requirements of each type of tactile ground surface indicators is as follows:

TABLE D1
Luminance Contrast

Tactile Ground Surface Indicator	Luminance Contrast Requirement
Integrated	0.30 to 30%
Discrete	0.45 or 45%
Composite Discrete	0.60 or 60%

D.3.15 Orientation and position

D.3.15.1 In general a warning treatment should be applied in a perpendicular direction, which is at 90 degrees, to the line of approach or to the target object. In addition, a warning treatment should be set back 300 mm from the hazard or target object.

D.3.15.2 A directional treatment is usually applied along the center line of the indicated path of travel and must provide a minimum clear width on either side of at least 800 mm in which there is no obstacle or obstruction.

D.4 APPLICATION OF TACTILE GROUND SURFACE INDICATORS

D.4.1 Pedestrian crossings and kerb ramps

D.4.1.1 Tactile ground surface indicators should be applied at pedestrian crossings as illustrated in Figure D7 (a).

D.4.1.2 Tactile ground surface indicators should be applied at kerb ramps as illustrated in Figure D7 (b).

Tactile ground surface indicators at pedestrian crossings and kerb ramps

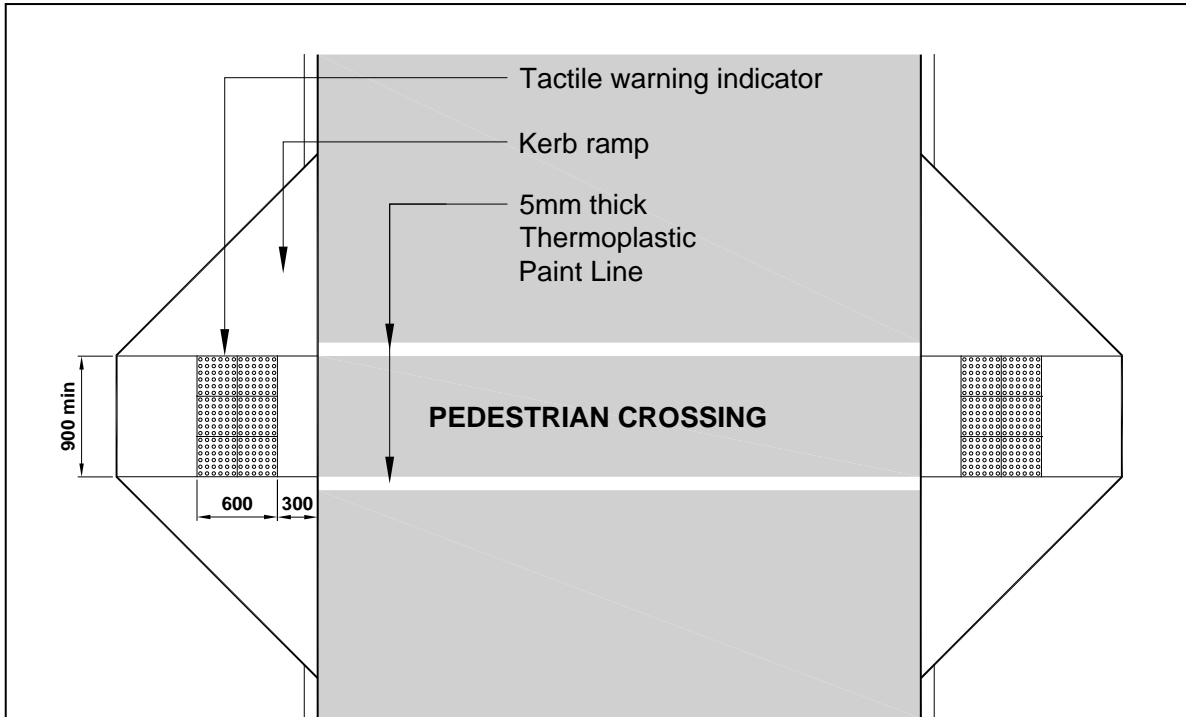

(a) Pedestrian crossing

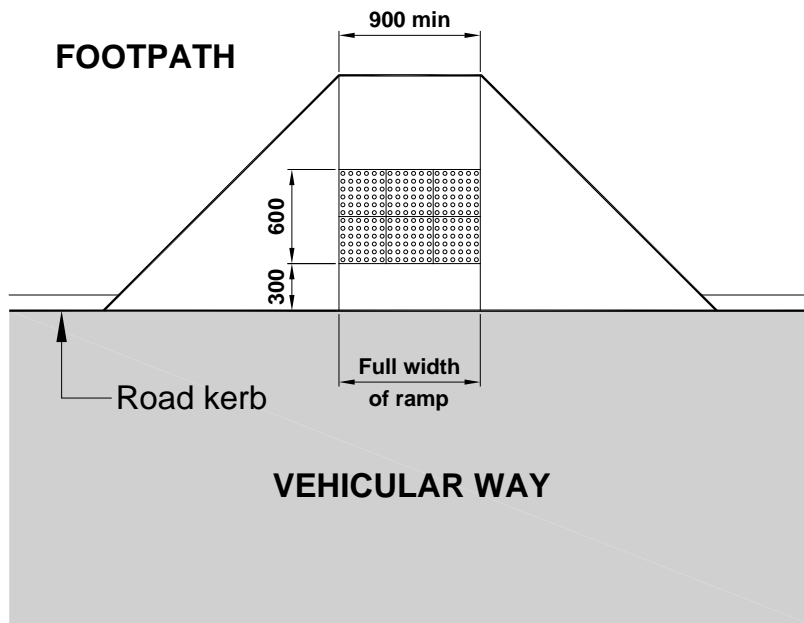

(b) Kerb ramp

Figure D7
Application of Tactile Ground Surface Indicators at Pedestrian Crossings and Kerb Ramps

D.4.2 Stairs, steps, escalators and passenger conveyors

D.4.2.1 Tactile ground surface indicators should be applied to stairs, steps, escalators and passenger conveyors as illustrated in Figure D8.

Tactile ground surface indicators at stairs, steps, escalators and passenger conveyors

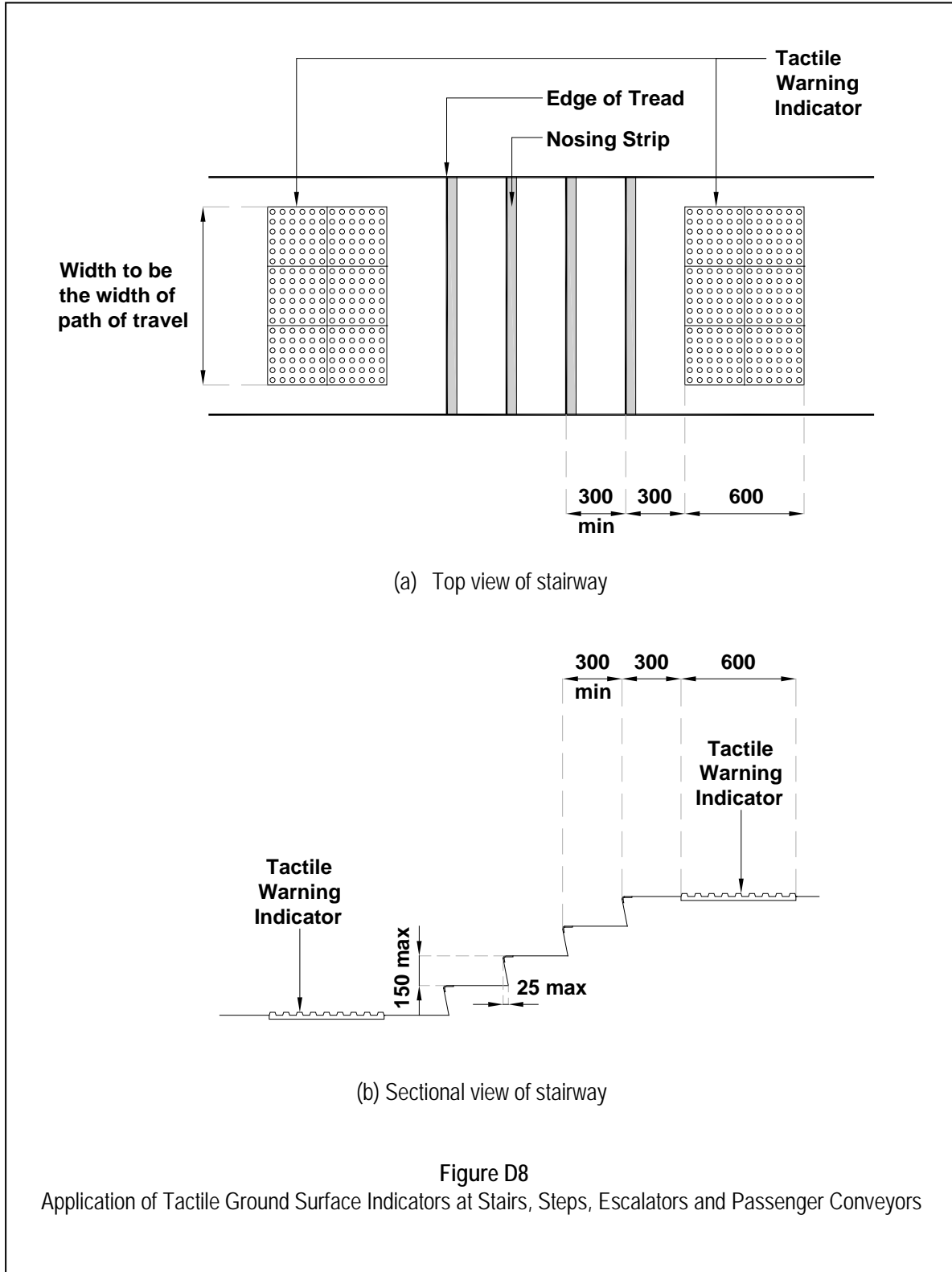

D.4.3 Flush pedestrian vehicular way

D.4.3.1 Tactile ground surface indicators shall be applied to flush pedestrian vehicular ways as illustrated in Figure D9.

Tactile ground surface indicators at flush pedestrian vehicular way

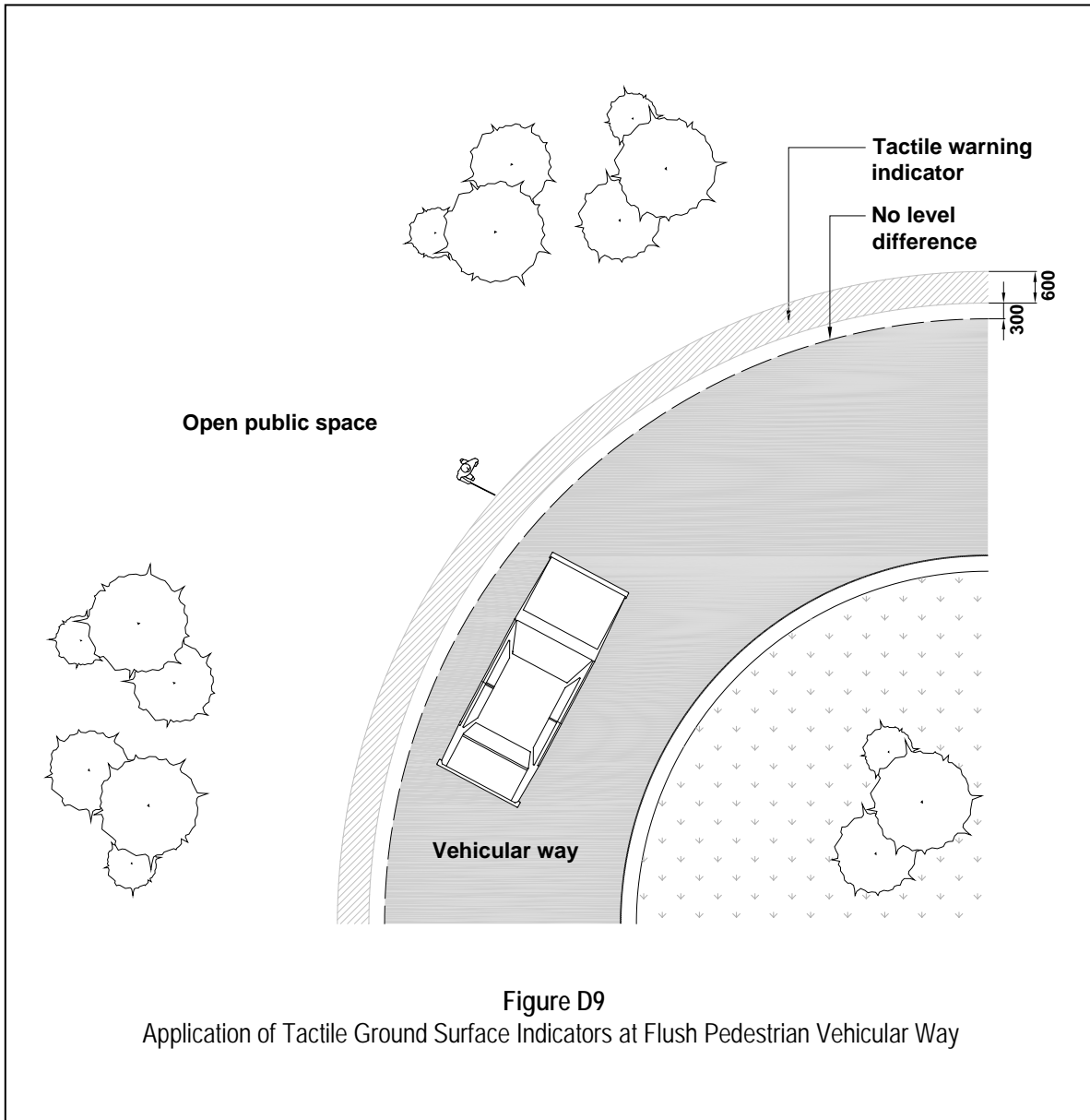

Figure D9
Application of Tactile Ground Surface Indicators at Flush Pedestrian Vehicular Way

D.4.4 Tactile guidance strips

Tactile guidance strips

D.4.4.1 Tactile guidance strips to guide persons with visual impairments around buildings should be applied as illustrated in Figure D10.

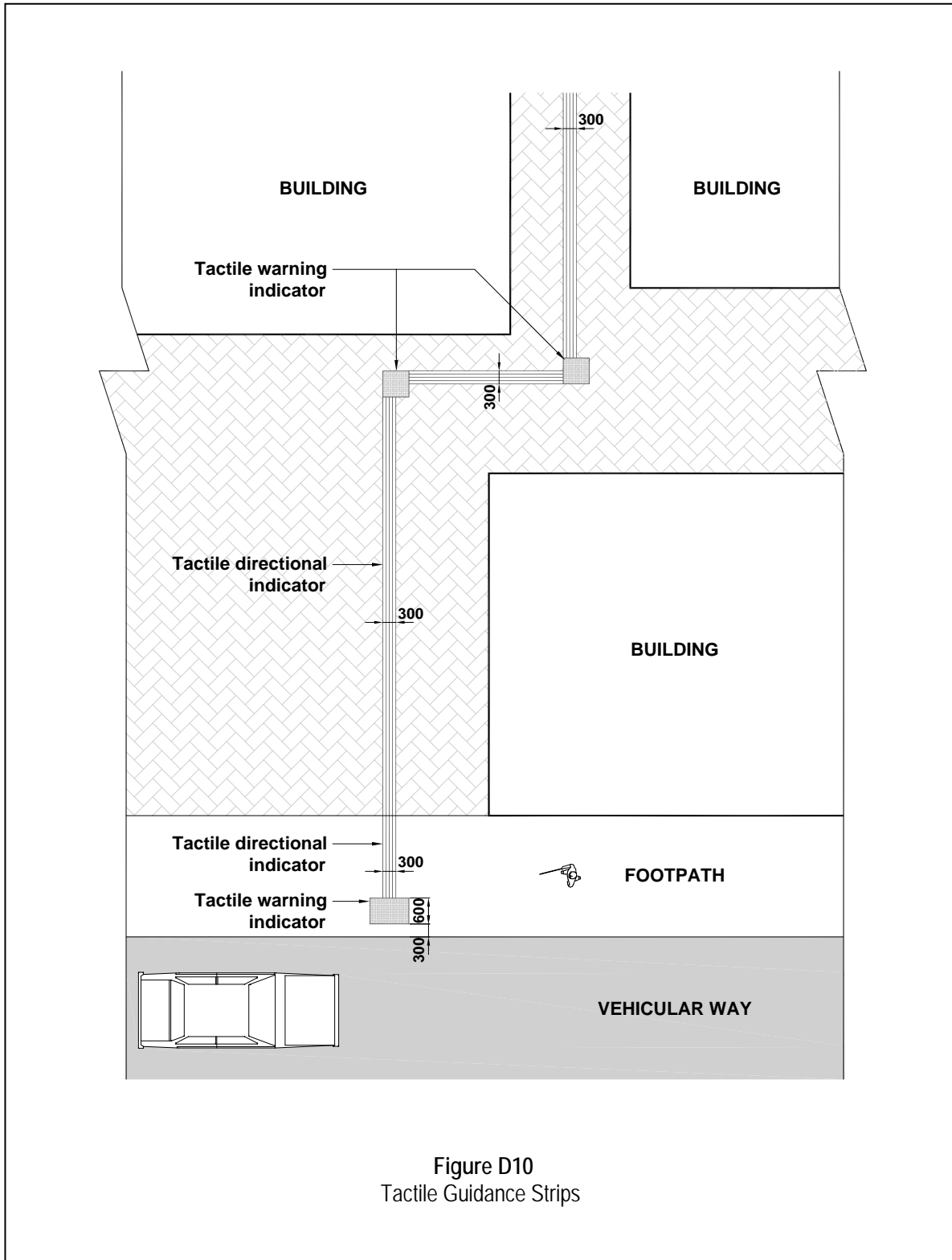

Figure D10
Tactile Guidance Strips

D.4.5	Materials	Tactile ground surface indicators materials
D.4.5.1	Tactile ground surface indicators are produced in a range of materials including concrete, ceramic, rubber, cork, steel and various resins. Some types are supplied in a tile format while others are applied with a spray-on technique.	
	When making a judgement as to which type to use, consideration should be given to:	
	(a) Internal versus external applications;	
	(b) New versus retrofit applications; and	
	(c) Availability and installation requirements.	
D.4.6	Impact of tactile ground surface indicators on other pedestrians	Impact of tactile ground surface indicators to pedestrians
D.4.6.1	A considerable amount of research has taken place to support the dimensional requirement for tactile ground surface indicators. This research has confirmed that the provision of tactile ground surface indicators at a dimensional height of 5 mm is sufficient to impart adequate tactile information whilst at the same time not adversely impacting on other pedestrians. The 5 mm pavement variance is generally accepted to be within the tolerances for pedestrian facilities.	

APPENDIX E

DESIGN GUIDELINES FOR PARKS AND OPEN SPACES

- Graduated Difficulty of Access CI E.1
- Outdoor Recreation Access Routes CI E.2
- Viewing Areas CI E.3
- Outdoor Steps CI E.4
- Outdoor Facilities CI E.5
- Signage CI E.6

E.1 GRADUATED DIFFICULTY OF ACCESS

Graduated difficulty of access

E.1.1 A system of graduated difficulty of access should be applied in outdoor recreational areas. A wide variety of trail types, each characterized by a degree of difficulty to negotiate should be provided whenever possible. By providing a diversity of trail types (with varying surfaces, widths, slopes, cross-slopes, lengths, edges, number of rest stops, etc.), a wider spectrum of opportunity with diverse experiences can be provided that will accommodate or challenge all people regardless of their abilities.

E.1.2 A good system of signage should enable one to choose for oneself the type of experience or degree of challenge desired. In this regard, it is not necessary that all facilities be totally accessible. Some may be difficult to negotiate even for the fittest individuals. The main objective is to provide greater diversity in trail types, based on an understanding of the wide variation of ability in people. Such a system does not compromise the recreational experience for anyone, and it also has the advantage of not always segregating the able-bodied from those who are not.

E.1.3 The guidelines in this appendix describe the standards that apply for the lowest difficulty level. Whenever possible, a park/site/project must provide at least one trail of the lowest difficulty level that traverses the entire park/site/project.

E.2 OUTDOOR RECREATION ACCESS ROUTES

Outdoor recreation access route

E.2.1 General

E.2.1.1 At least one outdoor recreation access route should be provided in parks and open space to connect key facilities, attractions and outdoor constructed features, as illustrated in Figure E1.

Connectivity

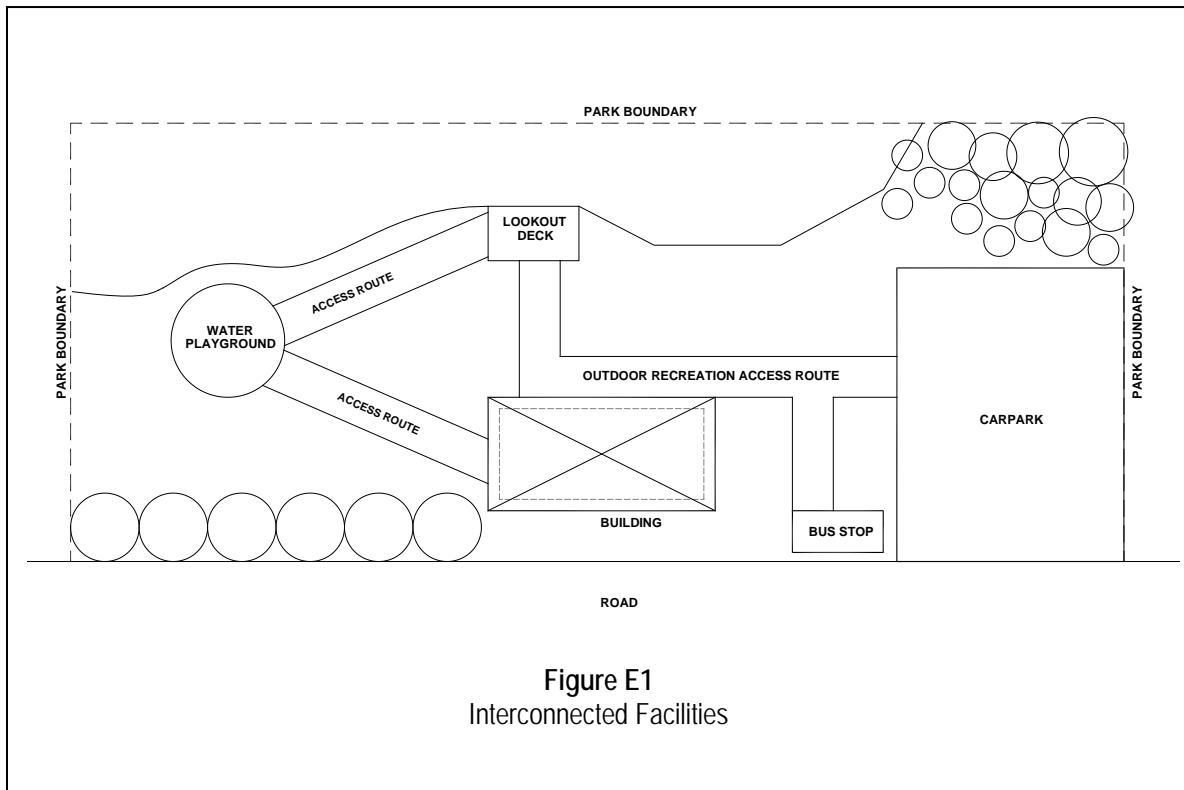
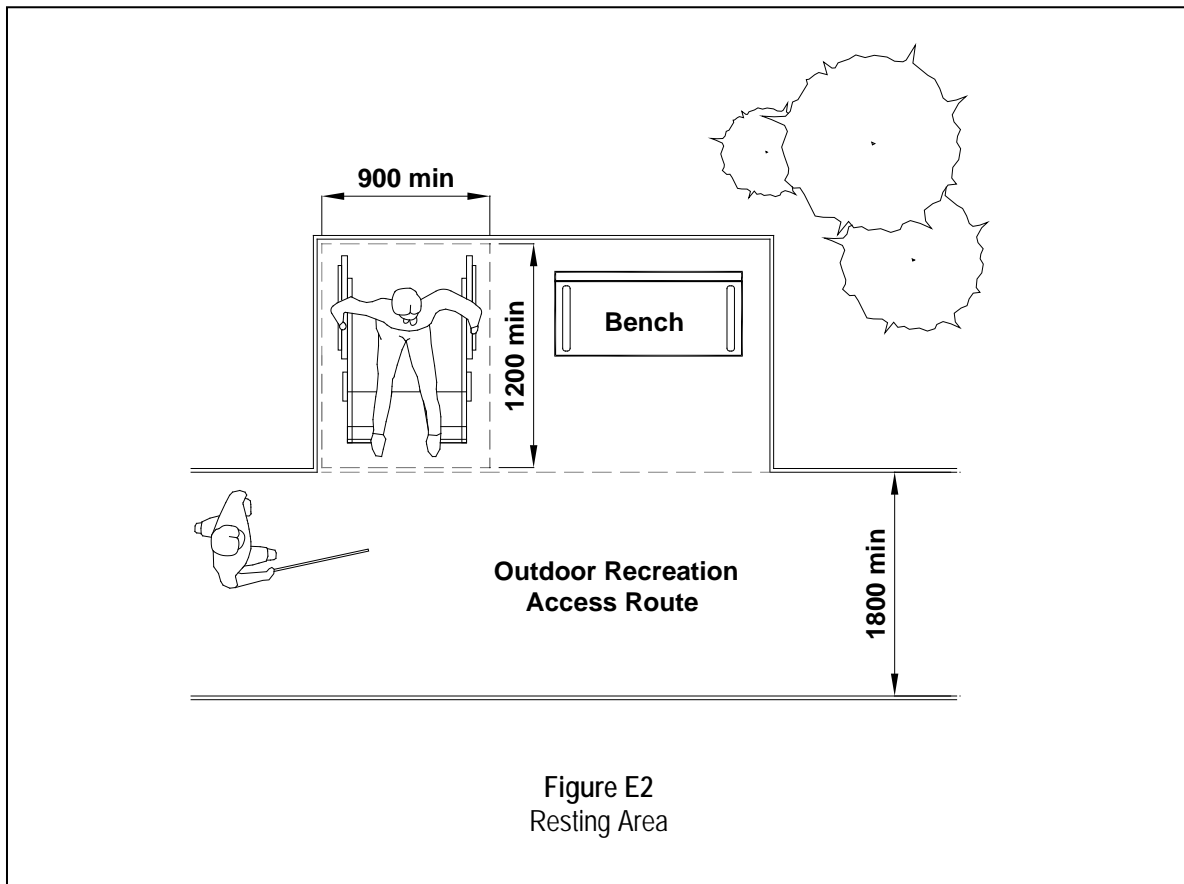

Figure E1
Interconnected Facilities

- | | | |
|---------|---|-------------|
| E.2.2 | Surface | Surface |
| E.2.2.1 | The surface of outdoor recreation access routes and their related circulation spaces and resting intervals should be firm, stable, slip resistant and free from water ponding. | |
| E.2.2.2 | Where the surface is concrete, asphalt, or board, obstacles should not exceed 6mm in height, measured vertically to the highest point. | Obstacles |
| Note: | <i>A stable surface remains unchanged by applied force so that when the force is removed, the surface returns to its original condition. A firm surface resists deformation by indentations.</i> | |
| E.2.3 | Clear Width | Clear Width |
| E.2.3.1 | The minimum clear width of outdoor recreation access routes shall be 1800mm. | |
| E.2.4 | Gratings | Gratings |
| E.2.4.1 | Where possible, gratings should be located outside the minimum clear width of the outdoor recreation access route. If this cannot be avoided, the long dimension shall be placed across the dominant direction of travel and the grating gap shall be less than 12 mm wide and in one direction, in accordance with clause 4.1.2. | |

- E.2.5 **Slopes** Slopes
- E.2.5.1 Outdoor recreation access routes should be level. If there is a change in level, the preferred gradient for any running slope should not be steeper than 1:25. Where the gradient is steeper than 1:25, it should be designed as ramped access in accordance with clause 4.6.
- E.2.5.2 The cross-fall gradient should not be steeper than 1:40.
- E.2.6 **Protruding Objects** Protruding objects
- E.2.6.1 Constructed elements on outdoor recreation access routes and their related passing spaces and protruding objects shall comply with clause 4.2.4.
- E.2.7 **Resting Areas** Resting areas
- E.2.7.1 Resting areas of at least 1800 mm in length and 1200 mm in width, as illustrated in Figure E2, should be provided at every 30 m interval along the access route. There should be space for wheelchairs or pushchairs alongside the provided seating. Some seating should have armrests and backrests to give support to people when resting.



E.2.8 **Edge Protection**

Edge protection

E.2.8.1 Where there is a direct drop of 200 mm or more along the access route, an upstand edge protection with at least 75 mm in height and 75 mm in width should be provided, as shown in Figure E3.

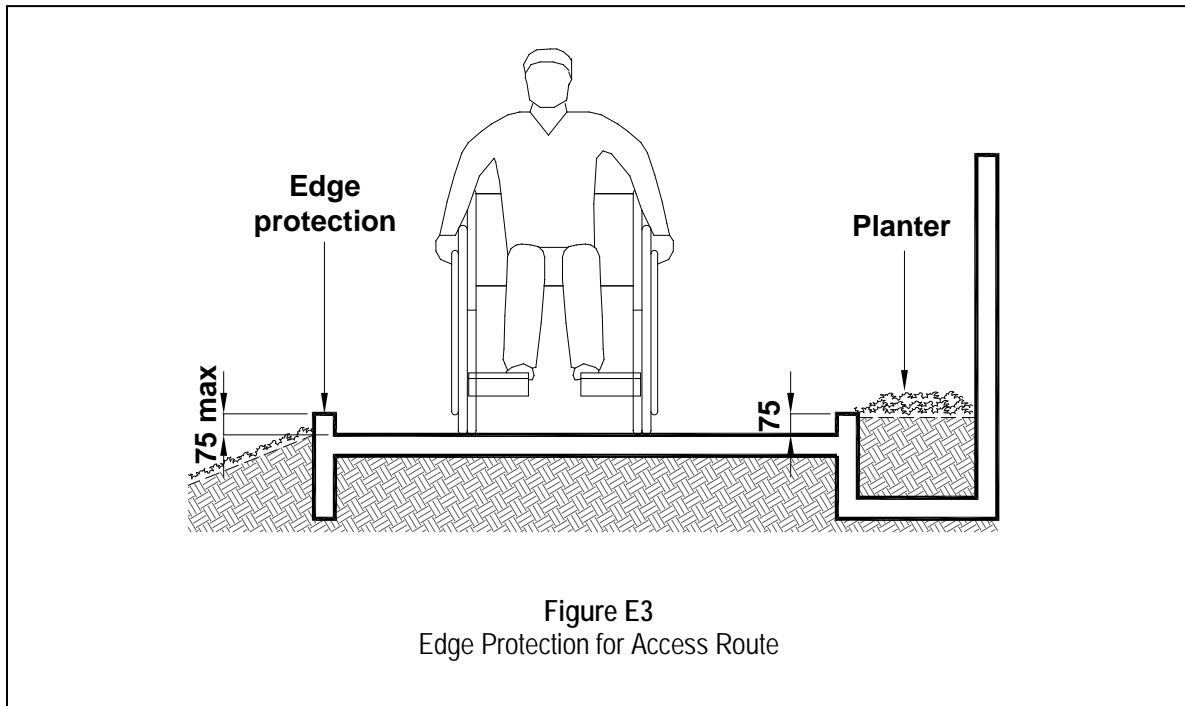

E.2.9 **Illumination**

Illumination

E.2.9.1 Access routes should be well lit with average 5 lux and minimum 1 lux.

E.2.9.2 Outdoor facilities and activity zones such as shelters, playgrounds and fitness corners should be well lit with average 20 lux.

E.3 **VIEWING AREAS**

Viewing areas

E.3.1 **General**

E.3.1.1 Viewing areas should provide distinct viewing locations for appreciating scenic views, natural beauty or points of interest.

E.3.2 **Clear Ground Space**

Clear ground space

E.3.2.1 A clear ground space of at least 1800 mm by 1200 mm should be provided at each distinct viewing location. The space should be positioned for either forward or parallel approaches to the viewing location. One full unobstructed side of the clear ground space should adjoin or overlap an outdoor recreation access route or another clear ground space as shown in Figure E4.

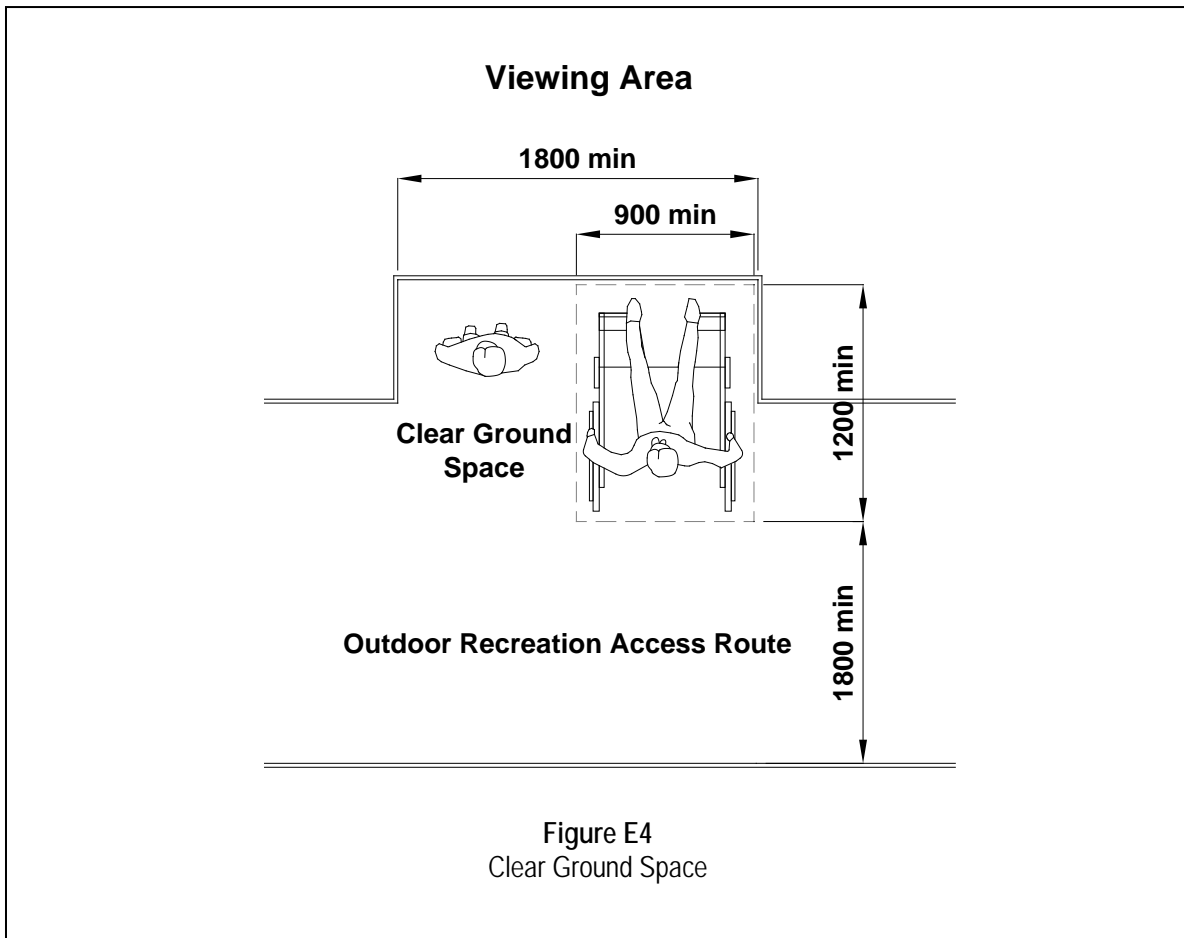

E.3.3 Unobstructed View

Unobstructed view

- E.3.3.1 An unobstructed view that extends the entire side of the clear ground space facing the landscape or point of interest should be provided at a height of between 800 mm and 1200 mm from the ground surface at each distinct viewing location as shown in Figure E5.

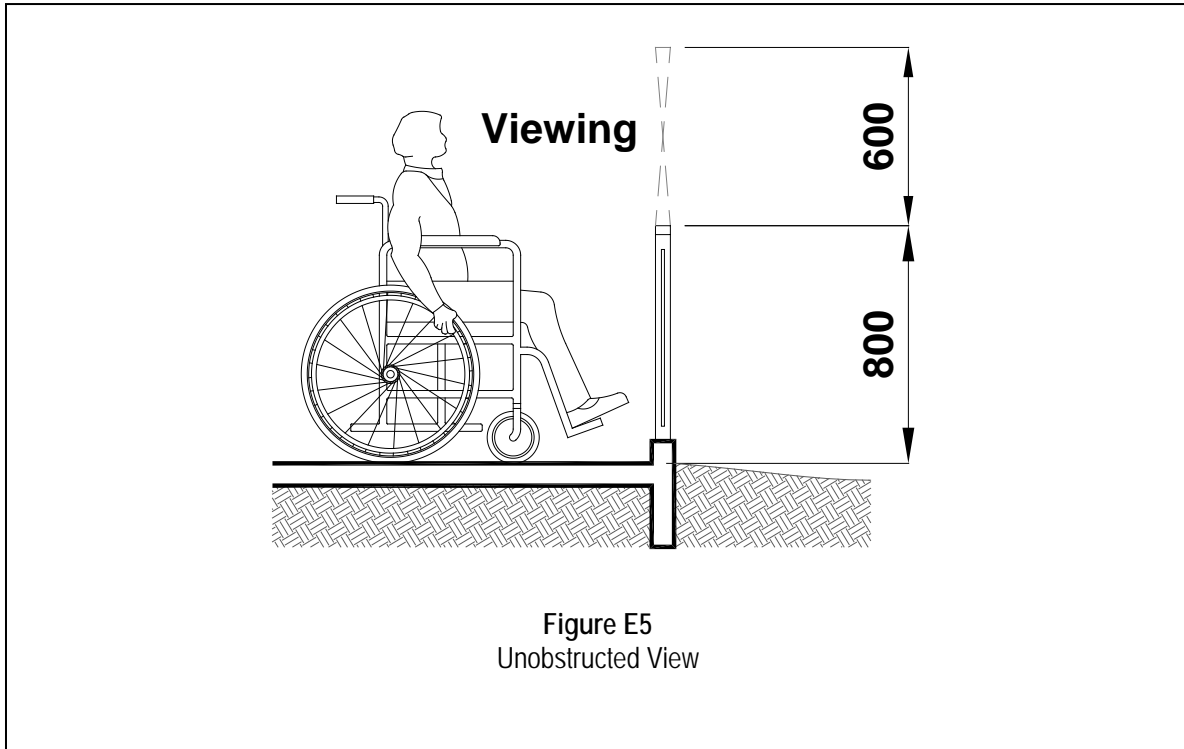

Note: *The above is not applicable to guiderails or other safety barriers which are provided to protect visitors from fall. However, consideration should be taken to minimize the obstruction of view towards the landscape or point of interest.*

- E.3.4 **Turning Space** Turning space
- E.3.4.1 A turning space of minimum 1800 mm diameter should be provided within viewing areas.
- E.3.5 **Surface**
- E3.5.1 The surface of clear ground spaces and turning spaces should be level, firm, stable and slip resistant.
- E.3.6 **Slope**
- E.3.6.1 The slope of the clear ground space and turning space surface should not be steeper than 1:50 in any direction.
- E.4 **OUTDOOR STEPS** Outdoor steps
- E.4.1 **Width**
- E4.1.1 The clear width of outdoor steps should be 1200 mm minimum.

E.4.2 **Step Riser and Tread**

E.4.2.1 Steps should have uniform risers of maximum 150 mm and treads of minimum 350 mm.

Note: *A flight of stairs should have a minimum of 2 steps.*

E.4.2.2 The riser and its corresponding tread for outdoor steps are recommended as shown in Table E1:

Table E1
Risers and Treads

Riser (mm)	Thread (mm)
120	410
125	400
130	390
135	380
140	370
145	360
150	350

E.4.3 **Landings**

E.4.3.1 The height between landings should not exceed 1500 mm.

E.4.3.2 The length of a landing should be 1500 mm or more as illustrated in Figure E6.

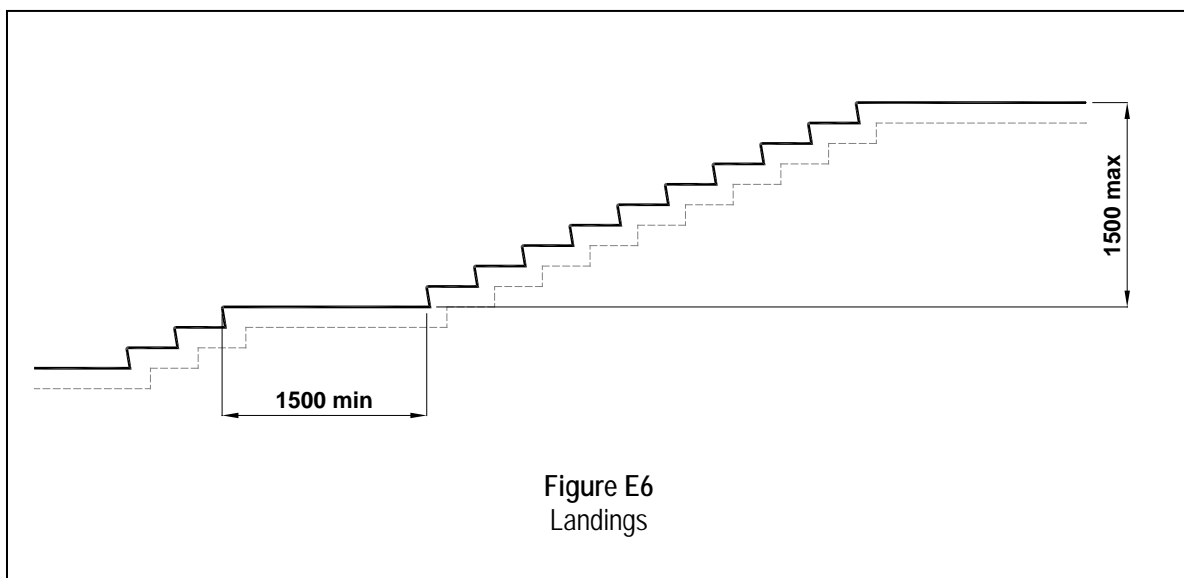

Note: *Longer landings should be in multiples of 1500 mm i.e. 1500 mm, 3000 m.*

E.4.4 Nosing

E.4.4.1 All nosing should be visible with permanent contrasting material to ensure good visibility. Highlights at the tread edges should be at least 50 mm deep and extend the full width of the step.

E.4.5 Warnings

E.4.5.1 Detectable warning surfaces should be used for the approach to the top and bottom of a flight of steps.

E.4.6 Handrails

E.4.6.1 Handrails for stairs should comply with clauses 4.7 and 4.11.4 while handrail for ambulant disabled stairs should comply with clause 4.7 and 4.12.

Note: *Additional handrails should also be provided for people with short statures at a height of between 600 mm to 750 mm.*

E.5 OUTDOOR FACILITIES

Outdoor
facilities

E.5.1 General

E.5.1.1 Outdoor facilities include picnic tables, BBQ pits, trash and recycling receptacles, outdoor rinsing showers, benches, telescopes and community garden planter boxes. At least 20% of the outdoor constructed features should be accessible and connected to an outdoor recreation access route.

E.5.2 Clear Ground Space

E.5.2.1 A clear ground space shall be provided at outdoor constructed features.

E.5.2.2 The size and location of the clear ground space should be in accordance with the Table E2. Unless otherwise specified in Table E2, at least one full unobstructed side of the clear ground space should adjoin or overlap an outdoor recreation access route or another clear ground space.

Table E2
Outdoor Constructed Features

Outdoor Constructed Features	Minimum Size & Location of Clear Ground Space
Picnic tables	900 mm along all usable sides of the table measured from the back edge of the benches
BBQ pits	1200 mm by 1200 mm on all usable sides
Trash and recycling receptacles	900 mm by 1200 mm positioned for forward approach to the receptacle opening; or 800 mm by 1500 mm positioned for a parallel approach to the receptacle opening.
Outdoor rinsing showers	1500 mm by 1500 mm with the shower heads positioned at the edge of the space
Benches	<p>900 mm by 1200 mm positioned near the bench with one side of the space adjoining an outdoor recreation access route or trail, as applicable.</p> <p>The clear ground space should not overlap the outdoor recreation access route or trail, or other clear ground space.</p>
Telescopes	<p>900 mm by 1200 mm positioned for forward approach to the telescope. Provide knee and toe clearance complying with clause 6.3.2.</p> <p>Locate the space so that the eyepiece is centered on the space.</p>
Community garden planter boxes	1200 mm by 1200 mm on all sides of the planter boxes.

- E.5.2.3 The surface of the clear ground space shall be firm and stable.
- E.5.2.4 The slope of the clear ground space shall not be steeper than 1:50 in any direction.
- E.5.3 **Picnic Tables** Picnic tables
- E.5.3.1 At least one wheelchair space of at least 900 mm by 1200 mm should be provided per table.
- E.5.3.2 Wheelchair spaces should be positioned for a forward approach to the table with knee space under the table complying with clause 6.3.2.
- E.5.4 **BBQ Pits** BBQ Pits
- E.5.4.1 Cooking surfaces should be between 700 mm and 1000 mm above the ground surface. Wheelchairs should be allowed for a forward approach to the cooking surfaces with knee space under the table complying with clause 6.3.2.
- E.5.5 **Trash and recycling receptacles** Trash and recycling receptacles
- E.5.5.1 Openings of trash and recycling receptacles should be at a height of not more than 800 mm above the ground surface.
- E.5.6 **Outdoor Rinsing Showers** Outdoor rinsing showers
- E.5.6.1 Outdoor rinsing showers shall provide at least two fixed shower heads. One fixed shower head shall be 1200 mm minimum and 1400 mm maximum above the ground surface, and one fixed shower head shall be 1800 mm minimum above the ground surface as illustrated in Figure E7.

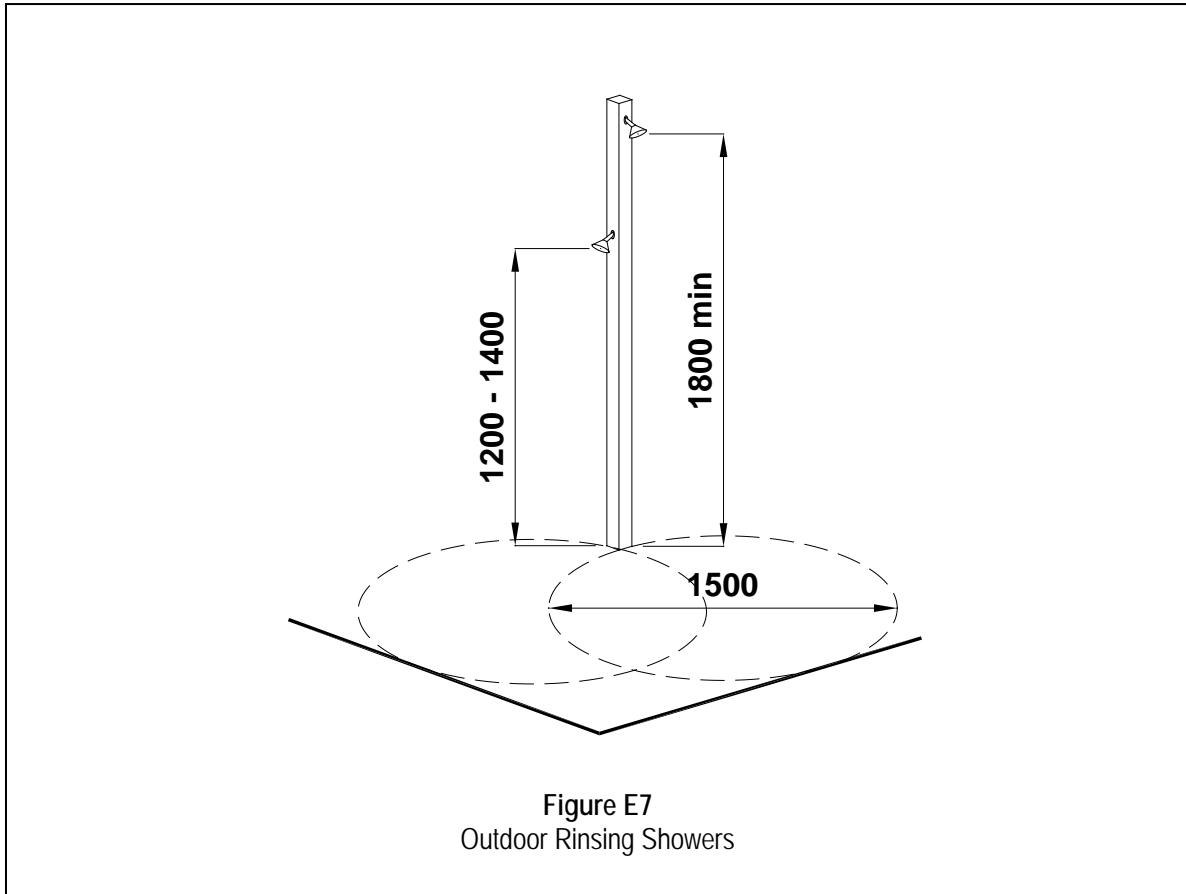

E.5.7 Telescopes

Telescopes

E.5.7.1 Eyepieces on telescopes should be at a height of between 1000 mm and 1300 mm above the ground surface as shown in Figure E8.

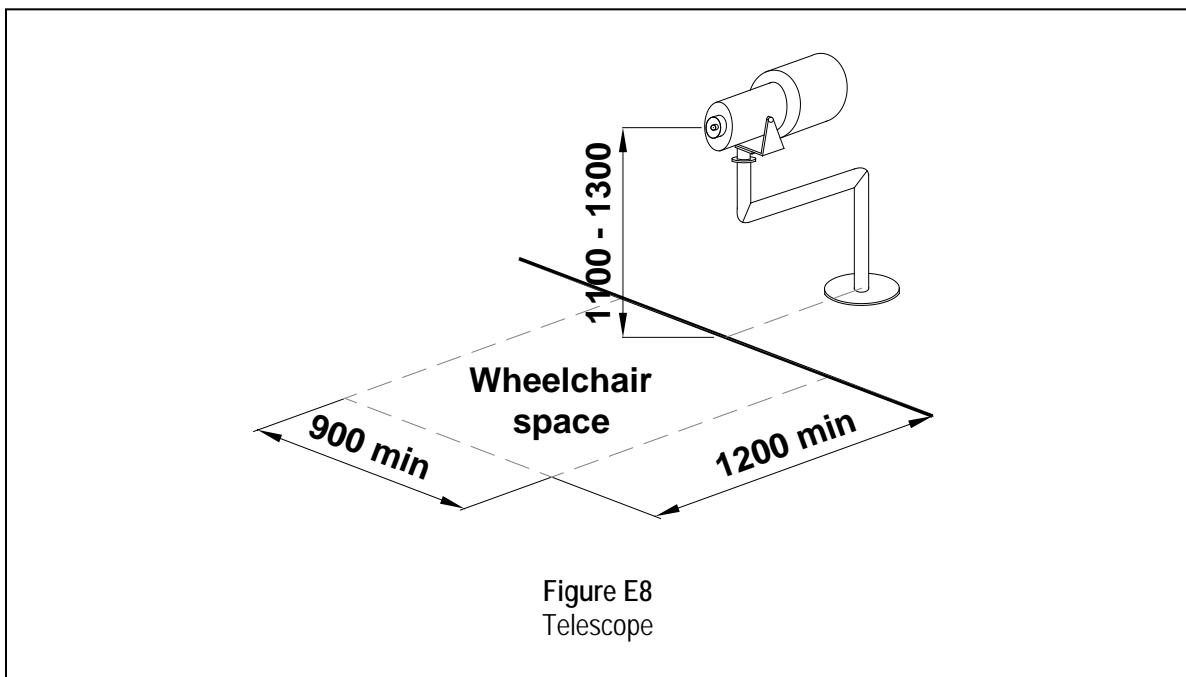

E.5.8	Community garden planter boxes	Community garden
E.5.8.1	Planting surfaces should be at a height of between 700 mm and 1000 mm above the ground surface. Wheelchairs should be allowed for a forward approach to the planting surfaces with knee space in accordance with clause 6.3.2.	
E.5.9	Public Toilets	Public toilets
E.5.9.1	Public toilets should be provided and located near to the main areas of attractions such as BBQ and picnic areas, playground area or other such use. At least one accessible toilet should be made available for wheelchair users.	
E.5.10	Shelters	Shelters
E.5.10.1	Shelters should be provided to protect against the weather. It should be accessible for those with mobility equipment such as pushchairs, wheelchairs, and the like.	
E.5.11	Accessible Parking	Accessible parking
E.5.11.1	Accessible car park lots for persons with disabilities should be located near adequately sheltered information points, or pedestrian entrances which allow easy movement for people with disabilities.	
E.5.11.2	Accessible pedestrian entrances should be physically separated from vehicles gaining access.	
E.5.11.3	Where bollards are erected at entrances to outdoor access routes, it should be provided according to clause 4.2.4.5.	
E.6	SIGNAGE	Signage
E.6.1	Information Board	Information board
E.6.1.1	Information Boards include map boards, notice boards and interpretive boards.	
E.6.1.2	A clear ground space of at least 900 mm by 1200 mm should be provided in front of information boards as shown in Figure E9. At least one full unobstructed side of the clear ground space should adjoin or overlap an outdoor recreation access route or another clear ground space.	
E.6.1.3	The surface of the clear ground space in front of information boards should be level, firm, stable and slip resistant.	

- E.6.1.4 The reading height of text should be between 700 mm and 1800 mm above the ground surface as illustrated in Figure E9.
- E.6.1.5 Graphic related text should be at least 5 mm minimum in height. Other text should be at least 8 mm minimum in height.
- E.6.1.6 Information on the outdoor recreation access route and accessible facilities should be indicated on relevant information boards.
- E.6.1.7 Information boards should be illuminated to at least a level of 200 lux.

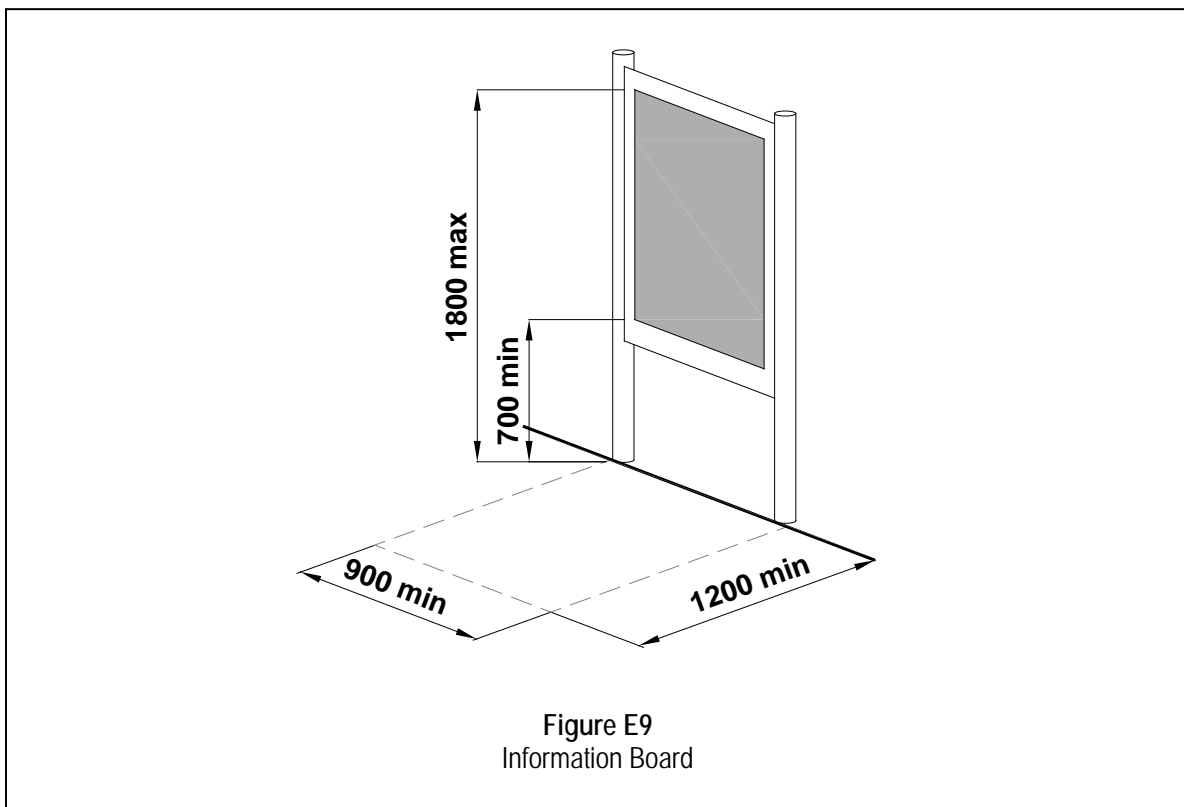

E.6.2 Directional Signs

Directional
Signs

- E.6.2.1 Direction signs should be placed at least 600 mm away from the outdoor recreation access route or trail. The outer limit of the sign should not overlap with outdoor recreation access route or trail as illustrated in Figure E10.
- E.6.2.2 The headroom clearance of the directional signs should be at least 2200 mm above the ground surface as shown in Figure E10.
- E.6.2.3 The height of text used on the sign should be 20 mm or more.
- E.6.2.4 Directional signs should be illuminated at a level of at least 200 lux.

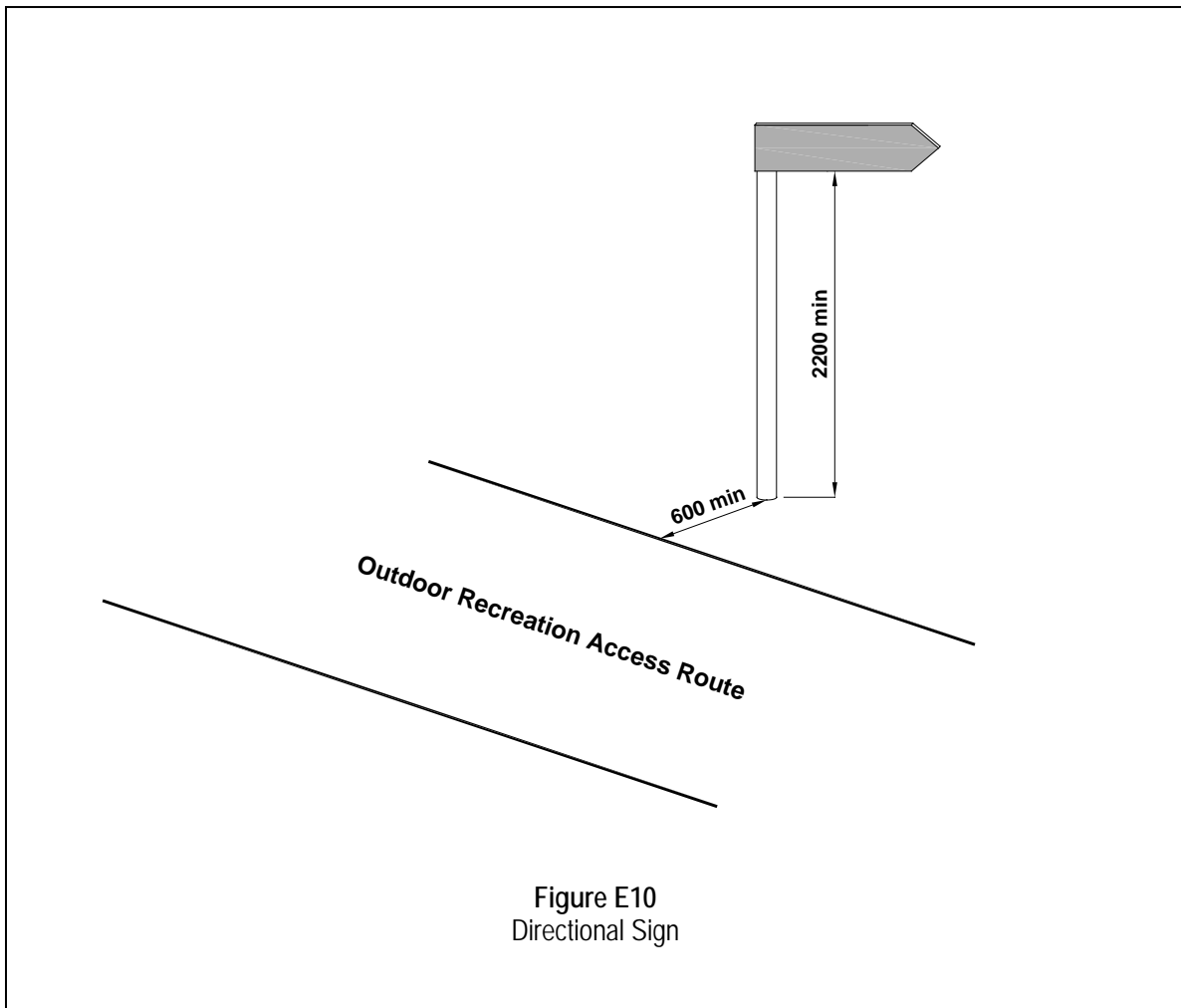

APPENDIX F

SLIP RESISTANCE OF FLOOR FINISHES

- Grading of Slip Resistance CI F.1

F.1	GRADING OF SLIP RESISTANCE	Slip Resistance Grading
------------	-----------------------------------	----------------------------

F.1.1 Materials to be used as floor finishes are graded under dry or wet conditions. The grading of the slip resistance of some of the typical materials is shown in Table F1.

F.1.2 In Table F1 the grading:

*Very good – means surface suitable for areas where special care is required, with an approximate coefficient of friction of more than 0.75;

*Good – means surface satisfactory for normal use with an approximate coefficient of friction of 0.4 to 0.75;

*Poor to fair – means surface below acceptable safety limits with an approximate coefficient of friction of 0.2 to 0.4; and

*Very poor – means unsafe surface with an approximate coefficient of friction of less than 0.2.

Note: Thick carpets are not recommended for wheelchair movement.

TABLE F1
Slip Resistance of Typical Flooring Surfaces

Material	Slip-resistance*		Remarks
	Dry and Unpolished	Wet	
Clay tiles (carborundum finish)	very good	very good	May be suitable for external stairs
Carpet	very good	good	
Clay tiles (textured)	very good	good	May be suitable for external stairs
Cork tiles	very good		
PVC with non-slip granules	very good	good	
PVC	very good	poor to fair	Slip-resistance when wet may be improved if PVC is textured. Edges of sheet liable to cause tripping if not fixed firmly to base.
Rubber (sheets or tiles)	very good	very poor	Not suitable near entrance doors.
Mastic asphalt	good	good	
Concrete pavers (Interlocking)	good	good	
Vinyl tiles	good	fair	
Linoleum	good	poor to fair	Edges of sheets may cause tripping if not securely fixed to base.
Concrete	good	poor to fair	If a textured finish or a non-slip aggregate is used, slip-resistance value when wet may be increased to good.
Granolithic	good	poor to fair	Slip-resistance when wet may be improved to good by incorporating carborundum finish.
Cast iron	good	poor to fair	Slip-resistance may be acceptable when wet if open treads are used.
Clay tiles	good	poor to fair	Slip-resistance when wet and polished – very poor
Terrazzo	good	poor to fair	Non-slip nosing necessary on stairs. Slip-resistance when polished or if polish is transferred by shoes from adjacent surfaces – very poor.
Marble/granite	good	very poor to fair	Slip-resistance when wet and polished – very poor

APPENDIX G

KEYPAD DESIGN REQUIREMENTS

- | | | |
|---|-------------------------------|--------|
| ▪ | General | CI G.1 |
| ▪ | Keypads Used Inside Lift Cars | CI G.2 |
| ▪ | Keypad Design | CI G.3 |
| ▪ | Registration of Calls | CI G.4 |
| ▪ | Notices | CI G.5 |

- | | | |
|------------|--|-------------------------------|
| G.1 | GENERAL | General |
| G.1.1 | For high-rise buildings, keypad control panels may be provided as an alternative for wheelchair users in addition to the traditional call buttons main control panel for lifts. Where keypad control panels are provided, the guidelines in this appendix are recommended to be adopted. | |
| G.2 | KEYPADS USED INSIDE LIFT CARS | Keypads used inside lift cars |
| G.2.1 | The keypad, emergency and control buttons including 'Door Open', 'Door Close', 'Alarm' and 'Intercom' are to be placed at a height of between 900 mm and 1200 mm from floor level. | |
| G.2.2 | Emergency and control buttons are not to be contained within the keypad to avoid accidental pressing. These emergency and control buttons shall always be provided in the same location even if there is no keypad used. | |
| G.3 | KEYPAD DESIGN | Keypad design |
| G.3.1 | The following are provisions recommended in keypad design as shown in Figure G1: | |
| | (1) The keypads should be arranged in the same way as telephone keypads. The ' * ' button should be replaced by ' - ' while the ' # ' button is replaced by ' E ' (for enter or return). | |
| | (2) The ' - ' button is to be used for correcting, cancel or clear a number entered or used to prefix a basement floor e.g. ' - 1 ' for B1, etc. | |
| | (3) The ' E ' button is to complete the keying sequence for the call (keyed string) to be processed. | |
| | (4) Each button shall be marked with Arabic numerals from 0 to 9. | |
| | (5) The ' 5 ' button shall have a tactile dot ' . ' at its center. | |

- (6) Each button should have an activating force of at least 3.5 N and beep (audibility between 35 dBA and 65 dBA) when pressed.
- (7) The ' E ' button should have a longer beep. An error of a call should have a series of at least 3 beeps.

G.4 REGISTRATION OF CALLS

Calls
registration

- G.4.1 Each call processed and accepted (after the ' E ' button is pressed) should be shown in the Indicator panel or in a separate panel as a queue for the stops. This queue shall be erased one at a time after each car stop is made.
- G.4.2 The lettering height shall be of at least 15mm for the stops queue and in contrasting colour/shade.
- G.4.3 If the stop queue is shown in a separate panel, this panel should be installed at a minimum height of 1700mm from floor level.
- G.4.4 To facilitate the visually impaired, the voice synthesizer should announce the floor stop upon arrival.

G.5 NOTICES

Notices

- G.5.1 The following notices in English shall be provided:
 - (a) Press number for floor and then press ' E ' to enter;
 - (b) Press ' - ' before number for basement floors; and
 - (c) Press ' - ' to correct, cancel or clear if wrong number is pressed.
- G.5.2 Notices as indicated in clause G.5.1 should be placed above the keypad and be accompanied with Braille for the visually impaired.

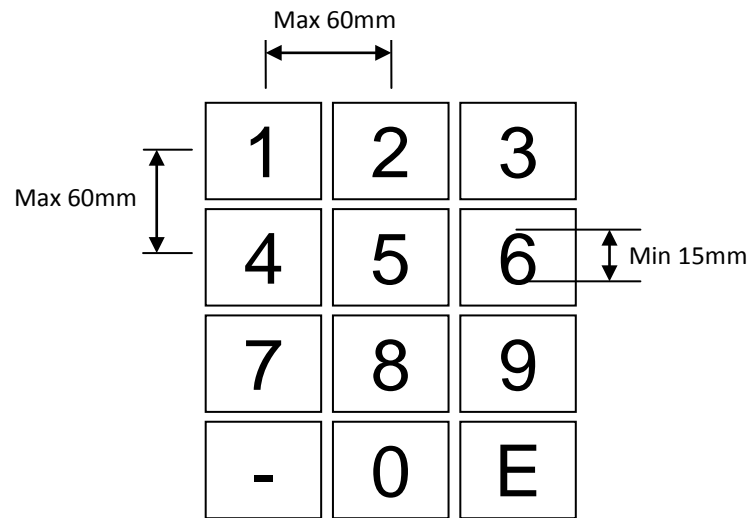

Figure G1
Keypad Buttons

COMPOSITION OF THE CODE REVIEW COMMITTEE

The Code Review Committee comprised the following organisations:

1. Government Agencies

- (a) Building and Construction Authority (Chair)
- (b) Housing and Development Board
- (c) Land Transport Authority
- (d) National Parks Board

2. Institution

- (e) National University of Singapore
- (f) Singapore Association of Occupational Therapists

3. Voluntary Welfare Organisations

- (g) Disabled People's Association
- (h) Handicaps Welfare Association
- (i) Singapore Association of the Visually Handicapped
- (j) The Singapore Action Group of Elders*

*Ceased operation in mid July 2012

4. Industry Players

- (k) Real Estate Developers' Association of Singapore
 - (l) Singapore Institute of Architects
-

